



2012 – 2013 BIOLOGY

3B Scientific

EuroDidact®



Printed on paper from
a sustainable forest company

3Bscientific.com

...going one step further

*Anatomy
Zoology
Botany*

*Cell biology
Genetics
Reproduction*

*Microscopy
Experiments
Software*





Otto H. Gies, Managing Director

Dear Customers,

The fast pace of change within biology generates ever new challenges. We hope that our wide range of products inspires you to provide your pupils with both exciting and instructive lessons. Our catalogue reflects the particular significance of experiments, models and microscopy. We should like to draw your attention to

- our brand new **Bacteriological Starter Kit** on page 139 as well as the Thin Layer Chromatography experiments on page 140
- the easy-to-operate and robust **Resuscitation Simulator Basic Billy** on page 147 developed and manufactured in Germany in accordance with the latest guidelines.
- the **LED Microscope and Digital Microscope Cameras** from page 63

Take advantage of the high standards of quality and didactic level of 3B Scientific® products at low prices. As an emissions study by the TÜV Nord has confirmed, all our products are toxicologically non-hazardous. Rely on the tried and tested quality of 3B Scientific and let us work together to introduce your pupils to the fascinating world of Biology.

With best wishes,

Otto H. Gies



page 147



page 139



page 66

Further 3B Scientific® Catalogues



Physics



Physics Experiments



Medical

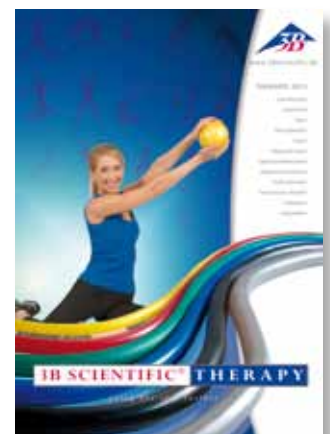

Physiotherapy

NEW**4-9 New Products****10 Anatomical Models Human**

- 10 Skeleton & Bones
- 15 Skull
- 18 Spinal Column
- 20 Vertebral Models
- 22 Pelvis
- 23 Joints
- 25 Muscular Figures
- 27 Torsos
- 32 Head, Teeth
- 33 Brain
- 35 Nervous System
- 36 Sensory Organs
- 40 Larynx, Lung
- 41 Heart Circulatory System
- 43 Digestive System
- 44 Urinary System
- 45 Reproduction and Development
- 47 Phylogenetics

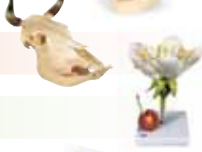
**48 Zoological Models****56 Botanical Models****60 Cellular Biology Models****63 Microscopy**

- 64 Course Microscopes
- 66 Course Microscopes for Advanced Users
- 71 Polarisation Microscopes
- 72 Microscopes with Built-In Camera
- 73 Laboratory Microscopes
- 74 Stereo Microscopes
- 78 Cameras
- 80 Accessories
- 84 Microscope Slides – School Sets
- 86 Microscope Slides – Series
- 96 Individual Microscope Slides
- 98 Multimedia Packages for Teachers and Students
- 108 Dissecting Kit

**110 Lab Material****113 Instrumentation****117 Measuring Instruments****120 Computer Aided Experimentation****123 Experiments**

- 123 Water / Earth / Air
- 125 Oxygen and pH Value / Water
- 126 Sampler
- 127 Heart/Circulation
- 128 Blood Tests
- 129 Sensory Physiology
- 132 Nervous System Physiology
- 133 Plant Physiology
- 134 Electrophoresis
- 136 PCR
- 137 Genetics
- 138 Osmosis
- 139 Microbiology
- 140 Thin Layer Chromatography

**141 Chemical Principles****147 Basic Life Support****148 Sex and Drug Education****152 Relief Models****154 Charts****166 Software****172 More Product Ranges****KEY**

- = Extra carriage charges
- = Product supplied with product manual
- www.** = Product manual available at www.3bscientific.com

C = Chinese, D = German, DÁN = Danish, E = English, F = French,
 FIN = Finnish, H = Hungarian, I = Italian, J = Japanese, K = Korean,
 L = Latin, NL = Dutch, NO = Norwegian, P = Portuguese, R = Russian,
 S = Spanish, SE = Swedish

Committed to Quality

3B Scientific provides you with good quality at fair prices. Our sophisticated quality management complies with the ISO 9001:2000 standards and the Worlddidac Quality Charter and is regularly approved by independent experts.

That's something you can rely on.

9 Reasons to Buy 3B Scientific Products

1 3-Year Quality Guarantee

If, despite of proper handling, you should discover any material or manufacturing defect within three years of the date of purchase, we will replace the product or correct the defect.

2 Low-Price Guarantee

With your purchase you obtain the highest quality at the lowest prices. If you can purchase a qualitatively comparable product at a lower price anywhere in the world within 14 days of purchase, you may return the product and we will refund the full purchase price.

3 14-Day Right of Return

If, for any reason, you should not be fully satisfied with a 3B Scientific® product, simply return it in the original packaging with a copy of the invoice within 14 days to receive a complete refund.

4 Rapid Delivery

We have an extensive range of products on site in our warehouse and can deliver most of the equipment within just a few days.

5 Special Discounts

When orders entail larger volumes you can benefit from extra savings. Please ask our sales team about special volume discounts.

6 Continuous Improvements

In order to be able to offer you the best possible quality, we continue to develop new products and innovate our manufacturing processes. For these reasons it might be the case that actual products appear slightly different from the ones illustrated here.

7 Expanding the Product Spectrum

We are constantly expanding our product range and therefore look forward to your ideas and comments to help inspire new developments.

8 Operational Worldwide

In general, our products can be put into operation anywhere. Please pay close attention to your local mains voltage, i.e. 230 or 115 volts, when connecting up equipment with a mains power supply.

9 Quality Management

As of June 2000 we have obtained a quality approval certification for service, products and organisational processes according to DIN EN ISO 9001:2008. This recognised Quality Management System has since lent us official support for our strategic commitment to innovation, product improvement and customer orientation. In addition to this we also continue to fulfil all of the quality standards associated with the introduction of the Worlddidac Quality Charter initiated in September 2004.

NEW



• Easy to use
• Realistic and Robust
• Adult and Child

Basic-Life Support Simulator
"Basic Billy"

9982-1012793

Page 147



MADE IN GERMANY

NEW



**Digital Monocular Microscope
with Built-in Camera**
9982-1013152

Page 72

Stereo Zoom Microscope
230 V, 50/60 Hz
9982-1013376

Stereo Zoom Microscope
115 V, 50/60 Hz
9982-1013373

Page 77



**Digital Camera
for Microscopes, 8 MPixel**
9982-1013379

Page 80



Monocular Course Microscope
230 V, 50/60 Hz
9982-1003271

Monocular Course Microscope
115 V, 50/60 Hz
9982-1003270

Page 66



LED Illumination

...going one step further

New Products

NEW



Electrophoresis Chamber
9982-1012852

Page 114



DNA Fingerprint
9982-1013458

Page 135



**Electrophoresis
Network Device**
9982-1010263

Page 114



**On the Trail of
Flavour Enhancers**
9982-1010263

Page 140

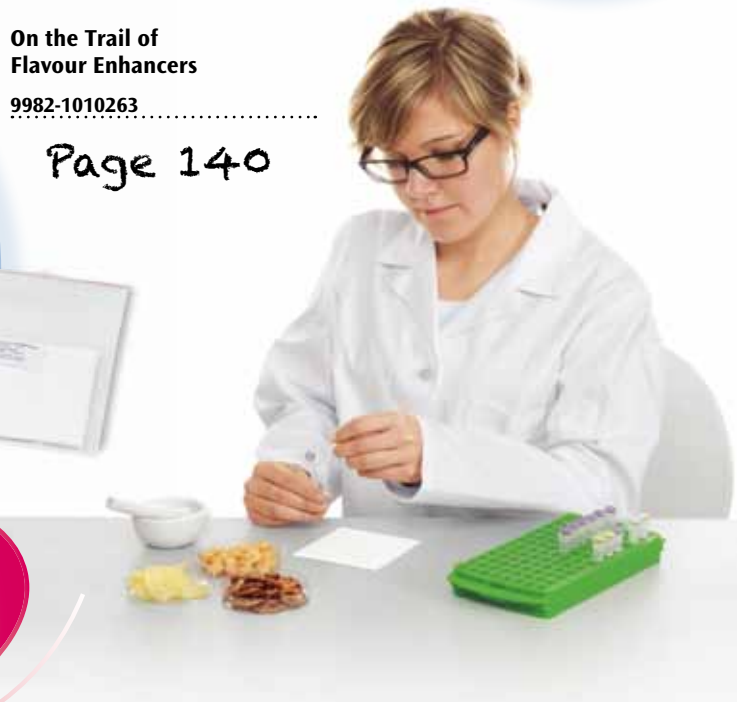

*Brand new and
topical - versatile
in classroom
situations*

NEW



Fast and highly-effective experiment



DNA Extraction from Onion
9982-1010264

Page 138



Bacteriology Starter Kit
9982-1013459

Page 139



Photosynthesis Equipment Set
9982-1012864

Page 133



...going one step further

NEW



**Pressure Equalisation
in the Middle Ear**

9982-1012829

Page 38



Organ of Corti

9982-1010005

Page 38

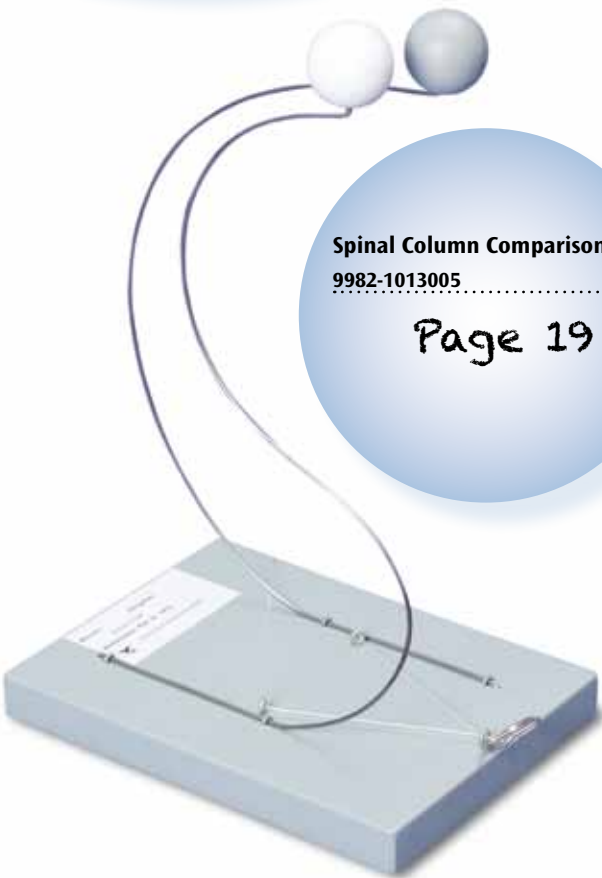

Spinal Column Comparison

9982-1013005

Page 19

Venous Valves in Operation

9982-1013002

Page 42

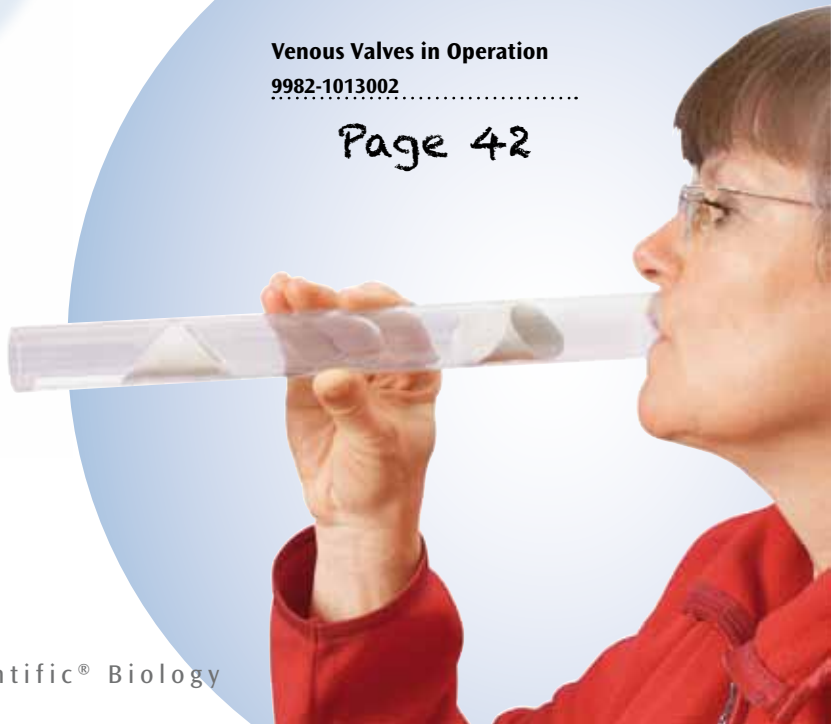

Digital Pocket Anemometer
9982-1010250

Page 119



Wireless Weather Station
9982-1010248

Page 119

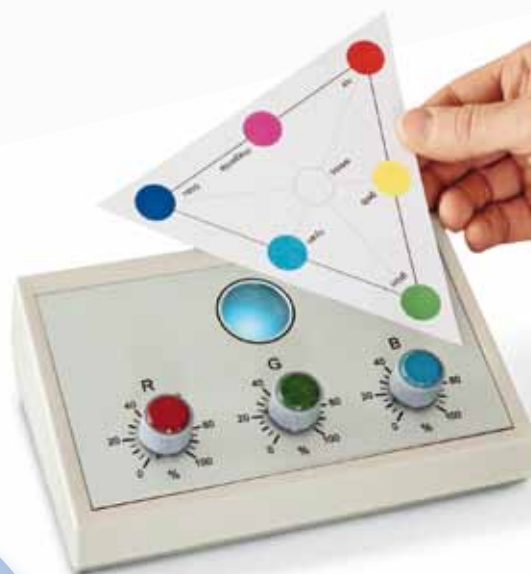

"Addition of Colours"
School Apparatus

9982-1012821

Page 129

Magnetic Stirrer with Heater
230 V, 50/60 Hz

9982-1002807

Magnetic Stirrer with Heater
115 V, 50/60 Hz

9982-1002806

Page 113



...going one step further

Microlitre Pipettes
with Variable Volume

9982-1013416

Page 111



3B Scientific® Skeletons – Value for Money

When choosing a skeleton model, you are bound to find considerable differences with regard to quality and price. A cheap skeleton may seem appealing to your budget, but does it also offer you reliable quality and attention to anatomical detail? Is it free of chemicals to ensure that you and your pupils, students, staff or patients are not subjected to any hazardous substances? Will it serve you well for many, many years or will you need to buy a replacement after only a few months?

Before making your purchase decision, please consider the following points:

- All 200+ bones are represented, even the hyoid and the styloid process
- A natural cast with true to original surface structure
- The arms and legs can be easily removed and reattached
- The skull can be disassembled and reassembled with ease
- Includes all subcranial openings
- The eye sockets are naturally shaped and the optic canal is portrayed
- The cartilage of the ribcage is hard wearing and robust
- The ribcage is assembled robustly and will not collapse in itself
- The materials used are high quality and durable
- All metal parts are made of stainless steel
- The model is safe and toxicologically harmless

Our range of true-to-original 3B Scientific® skeletons made of unbreakable plastic fulfils all of these demands. We grant you a three year warranty for that and the promise that every one of our skeletons is a high quality product with an outstanding price performance ratio. 3B Scientific not only promises quality on paper, but has made it the measure of all actions – ISO 9001:2008 certified and tested by independent auditors.

Classic Skeleton Stan, on 5 feet Roller Stand

This classic model (we call him Stan) has been the standard of quality in hospitals, schools, universities, and laboratories for over 50 years. Choose from 5 models to suit your individual preference – of course each one has all standard benefits of a 3B Scientific® skeleton.

170 cm; 7.6 kg

9982-1000010

BEST SELLER

Classic Skeleton Stan, on Hanging 5 feet Roller Stand with Brake

186 cm; 8.3 kg

9982-1000028



Detail of 9982-1000028



9982-1000010

All 5 leg roller stands have brakes

The Standard Benefits of a 3B Scientific® Skeleton:

- Excellent value for money
- 3-year warranty
- First-class natural cast “Made in Germany”
- Manual final assembly
- Made of durable, unbreakable plastic
- Almost natural weight for the approx. 200 bones
- Life-size
- 3-part mounted skull
- Limbs are quick and easy to remove
- Stand and transparent dust cover included
- All 5 leg roller stands have brakes

Details of the additional features of each individual model is provided in the product descriptions.



All 5 leg roller stands have brakes

9982-1000029

Classic Skeleton Max, on 5 feet Roller Stand with Brake

This version contains all standard benefits of a 3B Scientific® skeleton but additionally offers representations of the structural interaction between bones and muscles. It depicts over 600 structures of medical/anatomical significance including muscle origins (red) and insertions (blue) on the left side as well as hand-numbered bones, fissures and foramina on the right side.

170 cm; 8.0 kg

L/E www.3b.com

9982-1000029

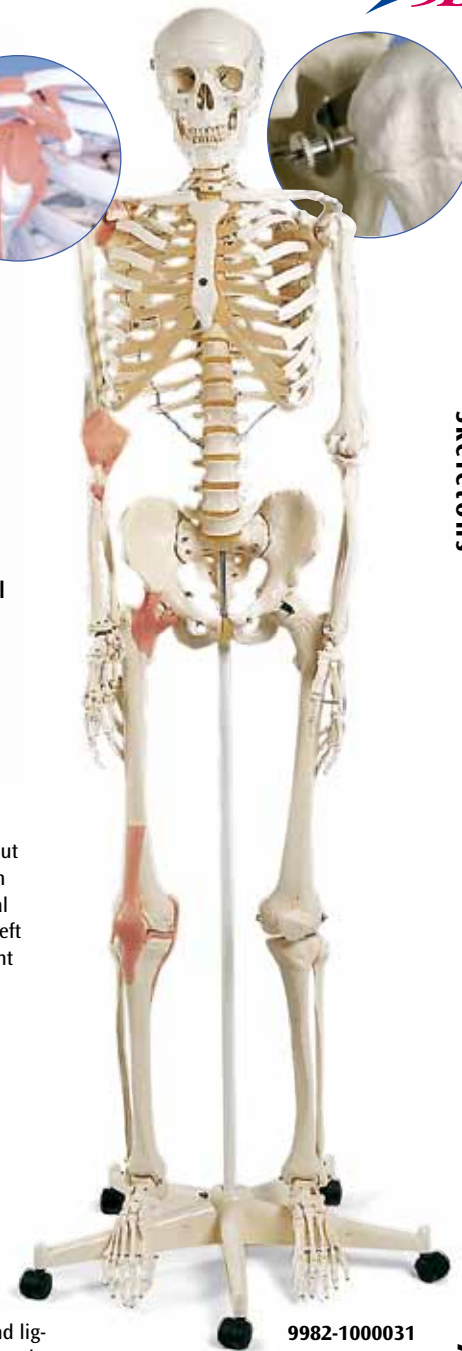

9982-1000031

Classic Skeleton Leo, on 5 feet Roller Stand with Brake

In addition to the standard benefits of a 3B Scientific® skeleton, Leo provides representations of the structural interaction between bones and ligaments. Its elastic ligaments on the major appendicular joints (shoulder, elbow, hip and knee) are mounted on the right side.

170 cm; 8.2 kg

9982-1000031

Look for our large selection of Charts starting on page 154.

Classic Skeleton Max Showing Muscles, on Hanging Stand with Brake

186 cm; 8.3 kg

L

9982-1000030

9982-1000030



Heavy Duty Dust Cover for Skeletons

Protect your investment with our heavy duty protective cover. Suitable for all skeletons and stand versions. Black with transparent window.

9982-1005468

9982-1005468



**BEST
SELLER**

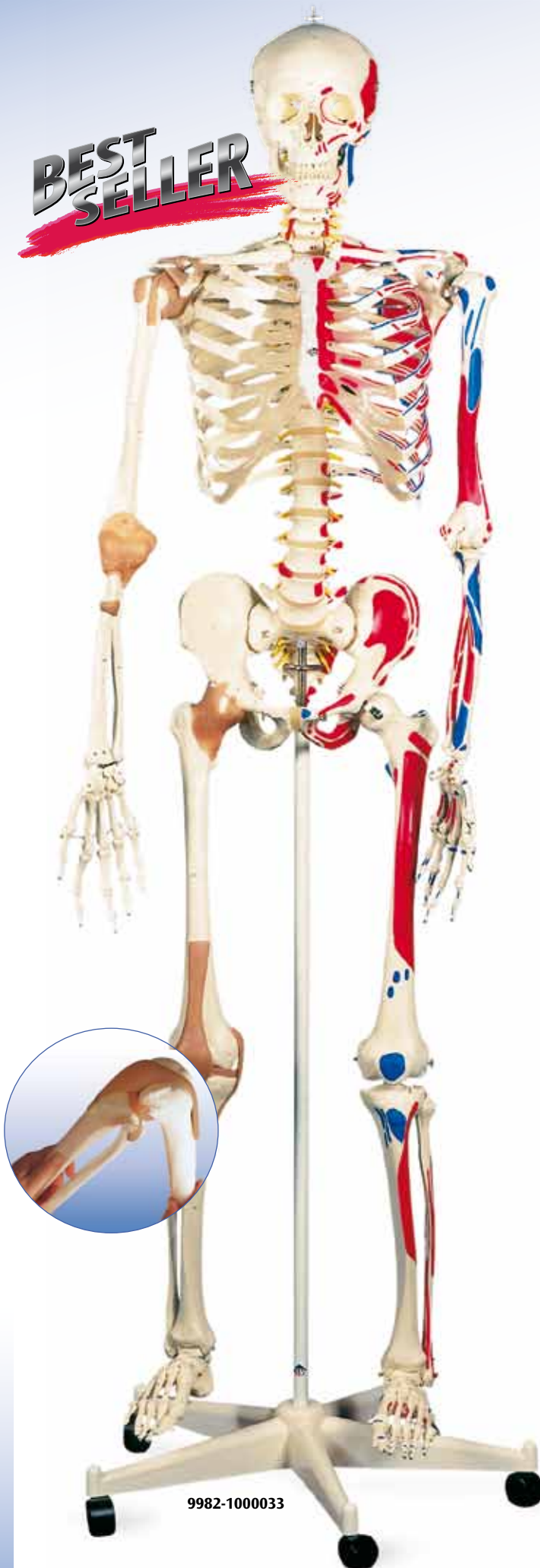

Sam Deluxe Skeleton, on 5 feet roller stand with brake

Of course this top of the range version contains all the benefits you have come to expect in our high quality 3B Scientific® standard skeletons. Sam additionally allows you to demonstrate the movements of the skull and head joints as well as all natural human postures due to the fully flexible vertebral column. The unique combination of flexible vertebral column, muscle origins and insertions, numbered bones, flexible joint ligaments and a disc prolapse between the 3rd and 4th lumbar vertebrae display over 600 structures of medical /anatomical interest in this top model.

To sum it up:

- All standard benefits of a 3B Scientific® Skeleton (see page 11)
- Over 600 hand-numbered and identified details
- Hand-painted muscle origins and insertions
- Flexible joint ligaments
- Flexible vertebral column
- Emerging spinal nerves and vertebral arteries
- Disc prolapse between L3 and L4

170 cm; 8.2 kg

L/E www.3bscientific.com

9982-1000033

Sam Deluxe Skeleton, on hanging stand with brake

Otherwise as 9982-1000033.

186 cm; 8.5 kg

L/E www.3bscientific.com

9982-1000034

Mini Skeleton “Shorty”, mounted on a base

Top of the range mini skeleton. Skillful 3B engineers using powerful hardware and software optimized the process of reproducing miniatures in order to keep all anatomical details and structures even at half natural size (80 cm). The skull can be removed and disassembled into three parts (skull-cap, base of skull, mandible) and the arms and legs are removable. The hip joints are specially mounted so their natural rotation can be demonstrated. 88 cm; 1.5 kg

9982-1000039

Mini Skeleton “Shorty”, on hanging stand (not shown)

This model is the same as the 9982-1000039 Mini Skeleton, but with a hanging stand. The stand can be either placed on the floor or attached to a wall.

94 cm; 1.7 kg

9982-1000040

Mini Skeleton “Shorty” with Painted Muscles, on base (not shown)

As 9982-1000039, but with coloured portrayal of the muscle origins (red) and insertions (blue) on the left half. The muscles are numbered.

L/D/E/F/I/S/P/J www.3b.com

9982-1000044

Mini Skeleton “Shorty” with Painted Muscles, on hanging stand

As 9982-1000044, but with hanging stand. The stand can be either placed on the floor or be suspended from the wall.

94 cm; 1.7 kg

L/D/E/F/I/S/P/J www.3b.com

9982-1000045

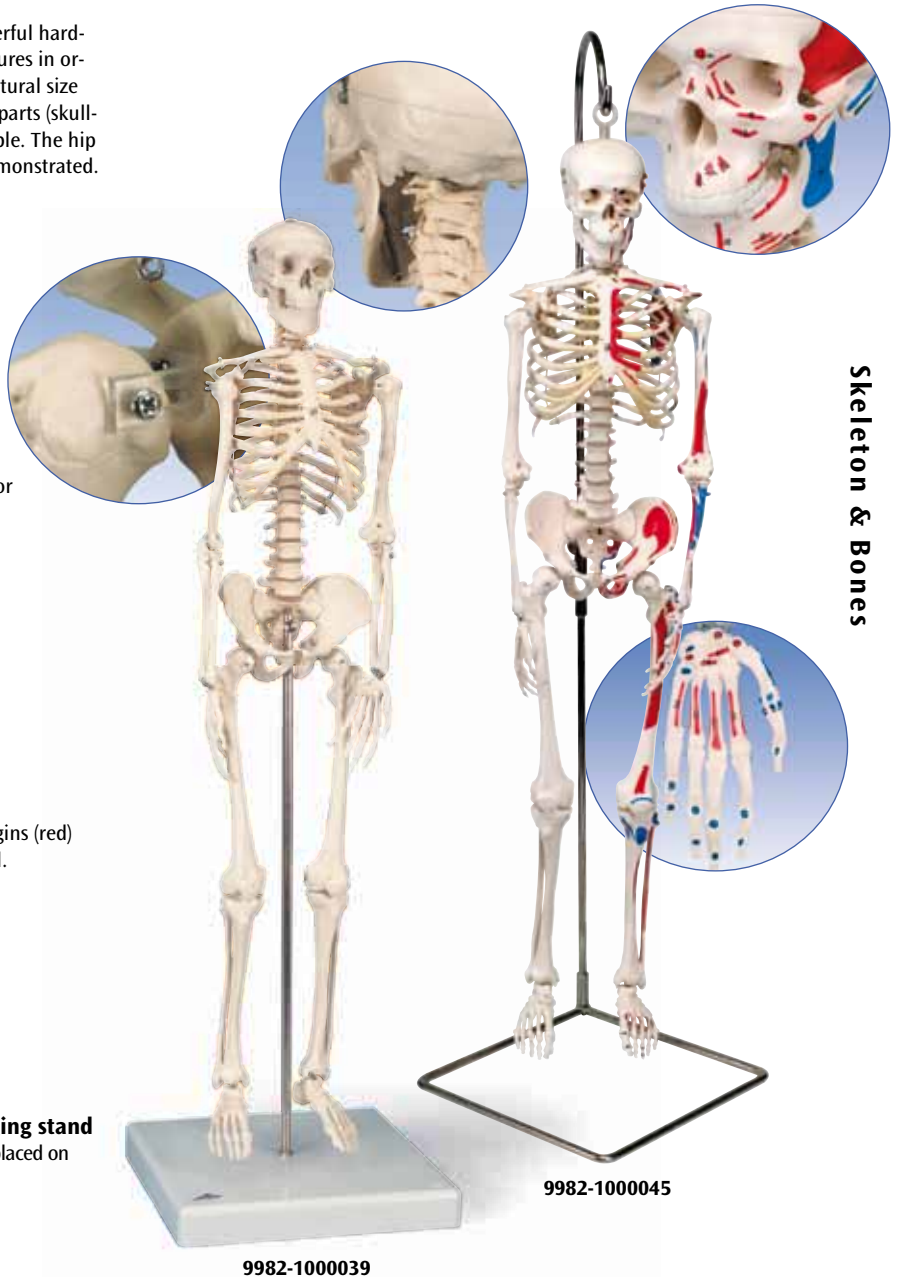

Skeleton & Bones

Anatomical Model Human

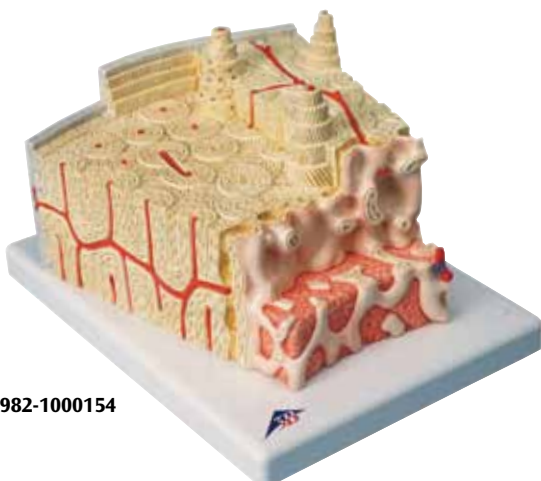

9982-1000154

3B MICROanatomy™ Bone Structure

This extremely detailed model depicts a three dimensional section of a lamellar bone, showing the typical structure of a tubular bone enlarged 80 times. Various planes are shown in cross and longitudinal section through all levels of the bone, as well as a 2-plane section through the inner structure of the bone marrow. The typical elements of a lamellar bone are easily identified and help to understand its structure and function with the characteristic osteons, also referred to as Haversian systems. This model gives a clear illustration of the interplay of the individual components, such as spongy and compact substance, endosteum, cortical substance, osteocytes, Volkmann and Haversian canals. Supplied on base.

26x19x14.5 cm; 0.8 kg

E/D/S/F/P/J www.3b.com

9982-1000154



9982-1000358

9982-1000357

Hand Skeleton Model with Ligaments and Muscles

The bones, muscles, tendons, ligaments, nerves, arteries, and veins are all featured in this high quality 4 part model of the hand and lower forearm. The dorsal side shows the extensor muscles as well as portions of the tendons at the wrist as they pass under the extensor retinaculum. The palmar face of the hand is represented in three layers, the first two removable to allow detailed study of the deeper anatomical layer. In addition clinically important structures such as the median nerve and superficial palmar arterial arch can be examined in detail. The deepest anatomical layer allows for study of the intrinsic muscles and deep palmar arterial arch in addition to other details.

33x12x12 cm, 0.4 kg

L/D/E/F/I/S/P/J/R/C www.

9982-1000358

Hand Skeleton Model with Ligaments and Carpal Tunnel

This 3 part hand model shows the anatomical details of the ligaments and tendons found in the hand, wrist, and lower forearm. The interosseous membrane between the radius and ulna is shown along with the bones of the hand. The flexor retinaculum is removable and in addition there is a removable portion that can be fitted onto the back of the model. This portion features the clinically important structures of the carpal tunnel such as the flexor retinaculum, median nerve, and tendons.

30x14x10 cm, 0.3 kg

L/D/E/F/I/S/P/J/R/C www.

9982-1000357

Foot Skeleton Model with Ligaments

This detailed model displays numerous important ligaments and tendons including the achilles and peroneus longus tendons of the ankle. The model consists of the bones of the foot and lower portions of the tibia and fibula, including the interosseous membrane found between them. All the anatomically important ligaments and tendons are shown.

23x18x30 cm, 0.6 kg

L/D/E/F/I/S/P/J/R/C www.

9982-1000359



9982-1000359



9982-1000349

Internal Hand Structure Model, 3-part

Full size hand model showing the superficial and internal structures of the hand, including bones, muscle, tendons, ligaments, nerves, and arteries (superficial and deep palmar arches). The palmar aponeurosis and plate of the superficial tendons are removable.

28.5x13x6.5 cm; 1.2 kg

L/D/E/S/F/P/I/J www.

9982-1000349

Foot Skeleton Model with Ligaments and Muscles

This model is the best of its kind for quality and value. This anatomically detailed model of the foot and lower leg can be disassembled into 6 removable parts for detailed study. The model features not only the bones but also muscles, tendons, ligaments, nerves, arteries, and veins. The frontal view features the extensor muscles of the lower leg. The tendons can be followed on their passage under the transverse and crucial crural ligaments all the way to their insertion points. In addition all tendon sheaths are visible. On the dorsal portion of the model the gastrocnemius muscle is removable to reveal deeper anatomical elements. The sole of the foot is represented in three layers; the first layer displaying the flexor digitorum brevis. This muscle can be removed revealing the quadratus plantae, the tendon of the flexor digitorum longus, and the flexor hallucis muscle. This second layer is in turn removable to display even deeper anatomical details.

23x26x19 cm, 1.1kg

L/D/E/F/I/S/P/J/R/C www.

9982-1000360



9982-1000360

Diversity of 3B Scientific® Skulls

Take advantage of the largest selection of human skull models. Whether it's the world's best-selling, our inexpensive classic skulls, the Beauchene skull or our incredibly realistic BONElike™ skulls, on the following pages you will surely discover the model you've always wanted. Let your requirements decide for you – you'll find what you're looking for here!

Skull



9982-1000046

Classic Skull, 3-part

Our Classic Skulls combine quality and value. Each of the 8 classic versions available are designed to show exceptional detail at an affordable price. The 3-part standard version 9982-1000046 is a first choice for basic anatomical studies or an attractive present. Alternatively, choose one of the more advanced versions exhibiting additional anatomical structures such as muscle origins/insertions, hand-numbered bones and structures or a supplementary complete 5 part brain. 20x13.5x15.5 cm; 0.6 kg

9982-1000046

**BEST
SELLER**



9982-1000047

Skull on Cervical Spine, 4-part

This flexibly mounted version on a stand with a cervical spine. Also represented are the hindbrain, spinal cord, cervical nerves, vertebral arteries, basilar artery and rear cerebral arteries. On stand. 20x13.5x15.5 cm; 1.4 kg

9982-1000047

Classic Skull with Brain, 8-part

This skull can be disassembled into:

- Skull Cap
- Base of Skull
- Mandible

The midsagittally divided brain (9982-1000226) is cast from an original anatomical specimen. The components of its left half are:

- Frontal and parietal lobe
- Temporal and occipital lobe
- Encephalic trunk
- Cerebellum

20x13.5x15.5 cm; 1.1 kg

L/E/D/S/F/J

9982-1000049



9982-1000226



9982-1000049

Anatomical Model Human



9982-1000054

Classic Skull with Opened Lower Jaw, painted, 3-part

Muscle origins (red) and insertions (blue) are represented on the left side of this model.

20x13.5x15.5 cm; 0.7 kg

L/D/E/S/F/P/I www.

9982-1000054



9982-1000052

Numbered Classic Skull, 3-part

Numbered skull with skull sutures drawn in colour.

20x13.5x15.5 cm; 0.7 kg

L/D/E/S/F/P/I www.

9982-1000052



9982-1000053

Classic Skull with Opened Lower Jaw, 3-part

This dental skull with opened mandible exposes the dental roots with vessels and nerves. The cranial bones, bone components, fissures, foramina and other structures are numbered. The cranial sutures are shown in colour, as are the meningeal vessels and venous sinuses.

20x13.5x15.5 cm; 0.7 kg

L/D/E/S/F/P/I www.

9982-1000053

3B Scientific® Beauchene Skull, 22-part, Didactic Coloured Version

This high quality natural cast made of durable, dimensionally stable plastic reveals the complex structure of the human skull in an exceptionally clear way. The 22 individual bones can be firmly and precisely assembled at the well defined skull sutures using robust inconspicuous connectors. This means that the skull can be handled without falling apart, which differentiates it from alternative wobbly models with magnetic connectors. The perfectly interlocked sutures illustrate the adhesion of a genuine human skull very realistically. The bones are didactically dyed in nine lasting colours for ease of identifying the various skull sections. Pairs of bone plates are the same colour.

The skull consists of the following individual bones:

- Parietal bone (left and right)
- Occipital bone
- Frontal bone
- Temporal bone (left and right)
- Sphenoid bone
- Ethmoid bone
- Vomer bone
- Zygomatic bone (left and right)
- Upper jaw (maxilla) with teeth (left and right)
- Palatine bone (left and right)
- Nasal concha (left and right)
- Lacrimal bone (left and right)
- Nasal bone (left and right)
- Lower jaw (mandible) with teeth

This popular model is produced using accurate casts of the individual bones of a genuine "exploded" skull of European origin and is ideally suited for training osteopaths as well as other professionals.

21x14x16 cm; 0.7 kg

E/D/S/F/P/I/J www.

9982-1000069

3B Scientific® Skull Kit – Anatomical Version, 22-part

as 9982-1000069, but not coloured

9982-1000068



9982-1000058

Foetal Skull, on Stand

Cast of a natural bone foetal head in the 30th week of pregnancy.

18.5x14.5x14 cm; 0.2 kg

9982-1000058

Foetal Skull (not shown)

as A26, but without stand

14x9x9 cm; 0.15 kg

9982-1000057

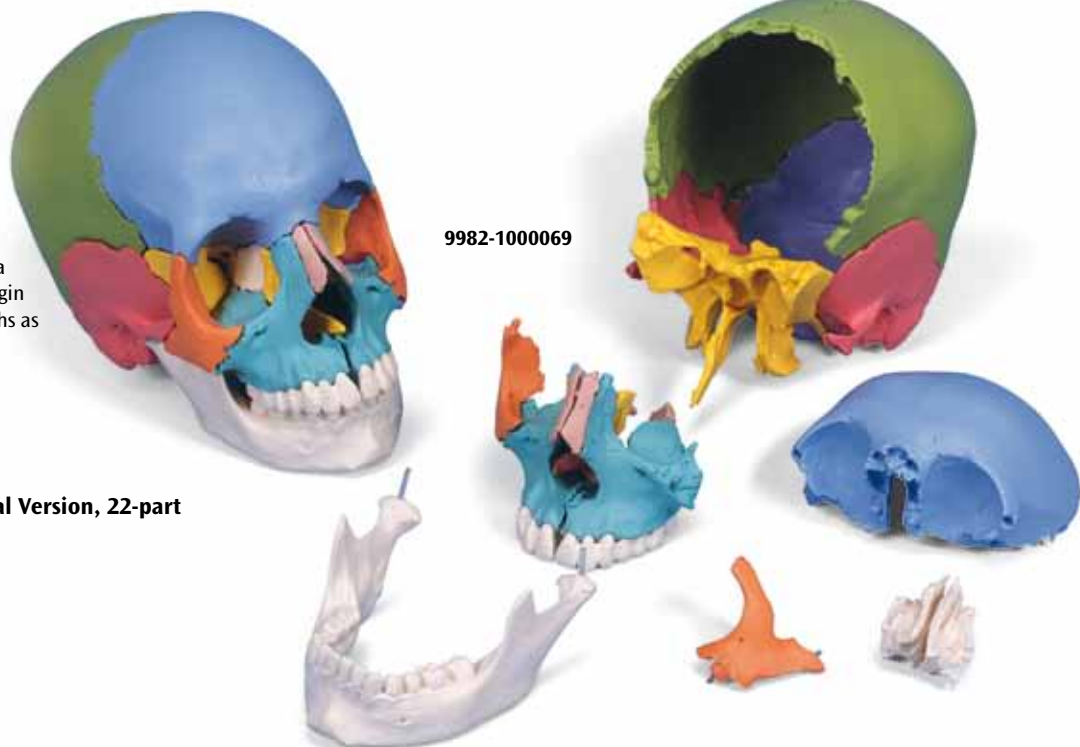

9982-1000069



9982-1000059

Deluxe Demonstration Skull, 10-part

This replica of the human skull is of an exceptional quality. The skullcap is removable and the base of skull is mid-sagittally divided. The frontal sinus, perpendicular lamina and vomer are fitted with flaps which can be opened to view the lateral nose wall and sphenoidal sinus. On the left half, the temporal bone can be removed and folded up in the area of the tympanic membrane. Maxilla and mandible are opened to reveal the alveolar nerves. On the right side the temporal bone is opened to reveal the sigmoid sinus, the facial nerve canal and the semicircular ducts. Additional flaps are located at the maxillary sinus and the right half of the mandible, so that the dental roots of the premolars and molars of the lower jaw can also be viewed. The natural occlusion and the individual removal and replacement of each tooth also make this skull especially interesting for dentists.

28x22.5x18.5 cm; 1.5 kg
 9982-1000059

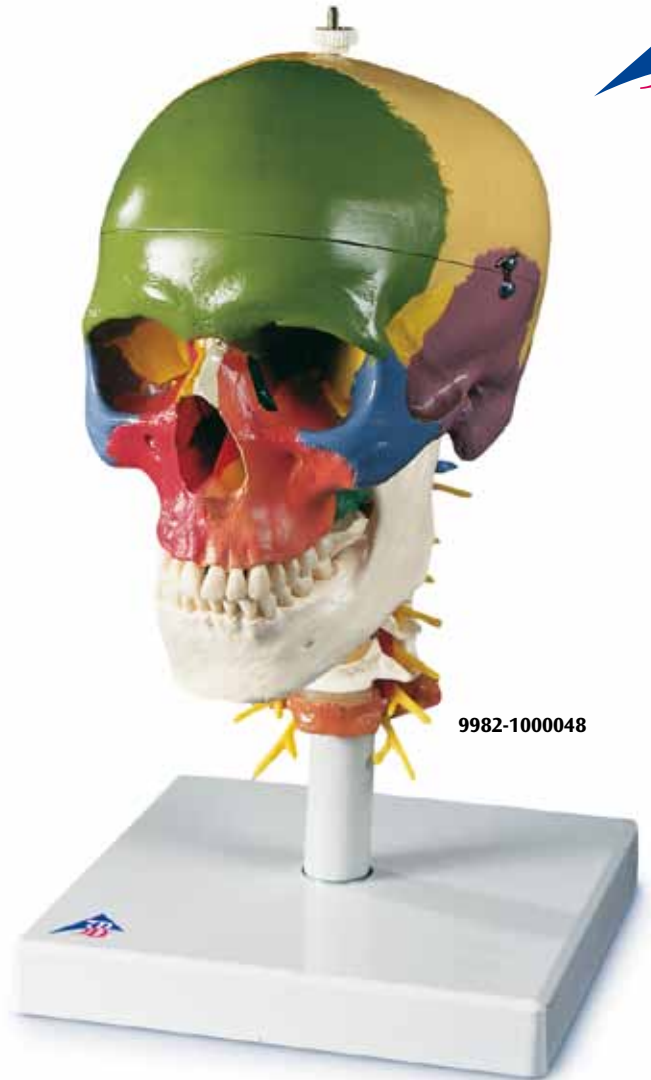

9982-1000048

Didactic Skull on Cervical Spine, 4-part

This model uses 19 didactic colours to demonstrate the shapes and relationships of the various bone plates of the skull. Flexibly mounted on the cervical spine (C1, C2 and C7 are coloured), this model also shows the hind-brain, spinal cord, spinal nerves of the cervical spine, vertebral arteries, basilar artery and rear cerebral arteries. Mounted on a stand.

18x18x30 cm; 1.4 kg
 E/D/S/F/P/J www.
 9982-1000048

3B BONElike™ System Skull – Bony Skull, 6-part

This unrivalled, detailed natural cast shows a complete midsagittally sectioned skull. It can be disassembled into both halves of the skullcap and the base of skull, the nasal septum and the complete mandible. To demonstrate masticatory movement, the lower jaw is mounted flexibly. An excellent skull to study the bony structure and complicated anatomy of the human skull. Manufactured from 3B BONElike™, this is the world's best series made skull replica.

16x14x21 cm; 0.5 kg
 E/D/S/F/P/J www.
 9982-1000062

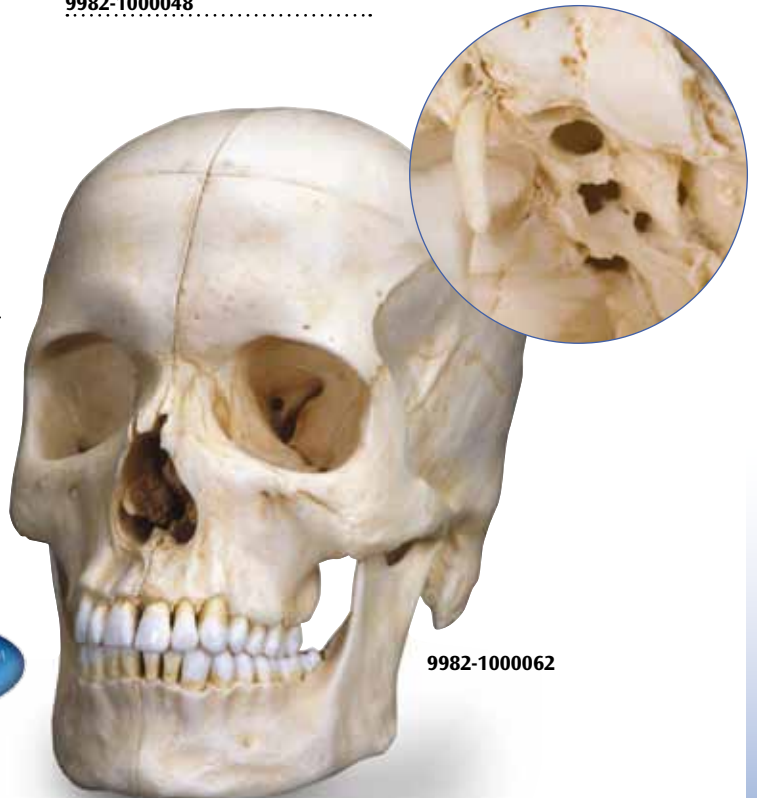

9982-1000062



Our complete product line can be found on www.3bscientific.com



9982-1000132



Classic Flexible Spine with Ribs

Flexible spine with ribs shows the interaction of the ribs, spine and associated structures. Contains the following features:

- Extremely good value and durable.
- Full pelvis and occipital plate
- Fully flexible mounting
- L3-L4 disc prolapsed
- Spinal nerve exits
- Cervical vertebral artery
- Male pelvis

Stand is not included, please see 9982-1000132.
74 cm; 2.8 kg

9982-1000119

Classic Flexible Spine with Ribs and Femur Heads

All other features as 9982-1000119.
83 cm; 3.0 kg

9982-1000120

Classic Flexible Spine with Femur Heads and Painted Muscles

Painted spines add a new dimension to demonstrations. Muscle origins (red) and insertions (blue) are painted on left innominate, femur and vertebrae. Same features as 9982-1000121. Stand is not included, please see 9982-1000132.
83 cm; 2.1 kg

L/D/E/F/S/P/I/J www.

9982-1000123

Classic Flexible Spine with Female Pelvis

All other features as 9982-1000121.
74 cm; 1.8 kg

9982-1000124

Classic Flexible Spine

Our most popular spine for patient education is also our most affordable. Fully flexible and designed for hands on demonstrations. Contains these features:

- Full pelvis and occipital plate
- Fully flexible mounting
- L3-L4 disc prolapsed
- Spinal nerve exits
- Cervical vertebral artery
- Male pelvis

Stand is not included, please see 9982-1000132.
74 cm; 1.8 kg

9982-1000121

Deluxe Flexible Spine

Additionally to all features of the Classic Spine Series our Deluxe Spine has a sacral opening and exposed brainstem for advanced studies. Other features are:

- Full pelvis and occipital plate
- Fully flexible mounting
- L3-L4 disc prolapsed
- Spinal nerve exits
- Cervical vertebral artery
- Male pelvis
- Cauda equine

Stand is not included, please see 9982-1000132.
74 cm; 1.8 kg

9982-1000125

Multifunctional Spinal Column Stand, 3-part

Unique worldwide:

- Can be placed on the floor
- Mounted on a wall!

Made of nickel-plated steel

9982-1000132

Classic Flexible Spine with Femur Heads

Same features as 9982-1000121, additionally with femur heads.
83 cm; 2.1 kg

9982-1000122

BEST SELLER

9982-1000121



9982-1000122

Pelvic Skeleton, female

See 9982-1000134 on page 22.



9982-1000126

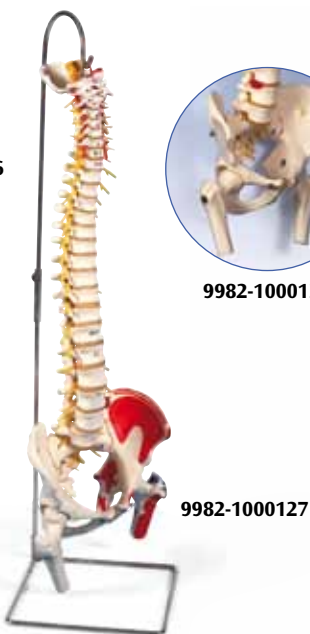

9982-1000127



9982-1000131



9982-1000130



9982-1008545



9982-1013005

NEW

Spinal Column

Deluxe Flexible Spine with Femur Heads

All other features as 9982-1000125. 83 cm; 2.1 kg
9982-1000126

Deluxe Flexible Spine with Femur Heads and Painted Muscles

Painted spines add a new dimension to demonstrations. Muscle origins (red) and insertions (blue) are painted on left innominate, femur and vertebrae. For further information see 9982-1000125. 83 cm; 2.1 kg
www.9982-1000127
9982-1000127

Flexible Spine with Soft Intervertebral Discs

Soft Discs for greater realism. This unique spine shows how the discs deform during normal and abnormal positioning. Use it to demonstrate any number of pathological conditions such as scoliosis, lordosis, kyphosis or subluxations. Herniation can be demonstrated with compression. In addition, the special mounting allows unobstructed vision viewing during demonstration and display. Includes dura mater of spinal cord and spinal nerves. Supplied on removable stand. 105 cm; 5.0 kg
9982-1008545



9982-1000043

Durable Flexible Spine

Probably the last spine you will ever need! With male pelvis, occipital plate, vertebral artery, spinal nerve exits and a dorsolateral disc prolapse between the 3rd and 4th lumbar vertebrae. Specially mounted on a flexible hose adding extra stability. Ideal for regular active use, such as in schools. Stand is not included, please see 9982-1000132. 74 cm; 1.4 kg
9982-1000130

Spinal Column Comparison

Using this functional model, you can clearly demonstrate the difference between the human spine and that of a mammal. The differences in structure and in how the spinal columns react to stress illustrates to the pupils how humans walk upright. Supplied with short description for teachers. 35x25x17 cm, 0.4 kg
9982-1013005

Mini Vertebral Column, Elastic, on stand

Model with squama occipitalis and pelvis. The vertebral column is mounted flexibly to demonstrate natural movements and pathological changes. On a detachable stand. 44 cm; 0.35 kg
9982-1000043

Durable Flexible Spine with Femur Heads

All other features as 9982-1000130. 83 cm; 2.3 kg
9982-1000131

Didactic Flexible Spine

This superb didactically painted spinal column has the same anatomical features as the 9982-1000121. The five different sections of the spinal column are differentiated by colour:

- 7 cervical vertebrae
- 12 thoracic vertebrae
- 5 lumbar vertebrae
- Sacrum
- Coccyx

Use this spinal column for simplified patient education or for lessons in a classroom environment where the didactical colours help to immediately reinforce the explanation, even from a distance. Stand is not included, please see 9982-1000132 (page 18). 74 cm; 1.9 kg
9982-1000128

Mini Vertebral Column, Elastic

As 9982-1000043, but without stand. 40 cm; 0.25 kg
9982-1000042

Didactic Flexible Spine with Femur Heads

All other features as 9982-1000128. 82 cm; 2.1 kg
9982-1000129

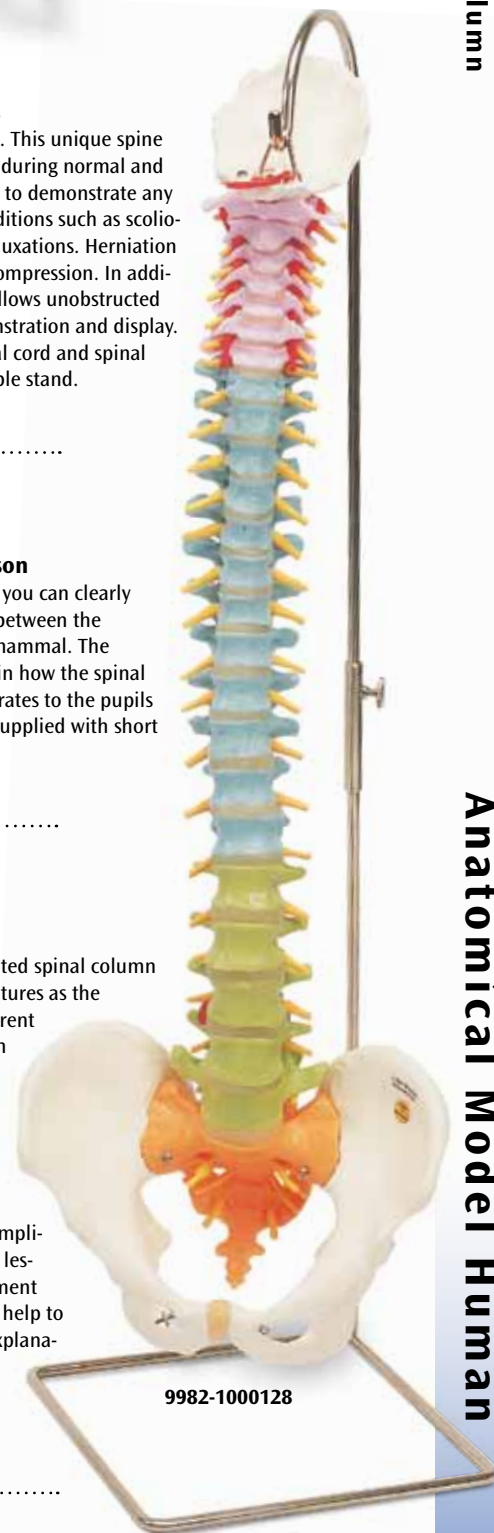

9982-1000128

Anatomical Model Human



9982-1000144



9982-1000145



9982-1000146

Cervical Spinal Column

Consisting of, occipital plate, the 7 cervical vertebrae with intervertebral discs, cervical nerves, vertebral arteries and spinal cord. On flexible stand. 19 cm; 0.3 kg

9982-1000144

Thoracic Spinal Column

Consisting of the 12 thoracic vertebrae with intervertebral discs, thoracic nerves and spinal cord. On flexible stand. 32 cm; 0.5 kg

9982-1000145

Lumbar Spinal Column

Consisting of the 5 lumbar vertebrae with intervertebral discs, sacrum with flap, coccyx, spinal nerves and dura mater of spinal cord. On flexible stand. 34 cm; 0.6 kg

9982-1000146



9982-1000147

6 Mounted Vertebrae

Consisting of atlas, axis, another cervical vertebra, two thoracic vertebrae with inter-vertebral discs and one lumbar vertebra. On removable stand. 22 cm; 0.3 kg

9982-1000147

5 Vertebrae (not shown)

Atlas, axis, cervical, thoracic and lumbar vertebrae. Loosely threaded on nylon.

9982-1000148



9982-1000141

Atlas and Axis

Assembled, on removable stand

9982-1000141

Atlas and Axis (not shown)

Assembled, no stand

9982-1000140

Lifting Demonstration Figure

Demonstrates graphically the effects of correct and incorrect lifting techniques on the spinal column. 28x21x21.5 cm; 1.4 kg

E

9982-1005101



9982-1000142

Atlas and Axis, with Occipital Plate

Assembled, on removable stand

9982-1000142



9982-1000139

Sacrum and Coccyx

Assembled

9982-1000139

2 Lumbar Vertebrae with Prolapsed Disc, Flexibly Mounted

With spinal nerves and dura mater of spinal cord. 7.4 cm; 0.15 kg

9982-1000152



9982-1000152

9982-1000151

Lumbar Spinal Column with Prolapsed Intervertebral Disc

2 lumbar vertebrae with spinal nerves, dura mater of spinal cord and 2 replaceable dorso-lateral prolapsed discs between the 4th and 5th lumbar vertebrae. On stand, removable. 13 cm; 0.27 kg

9982-1000149



9982-1000149

3 Lumbar Vertebrae, Flexibly Mounted

Anatomically correct in every single detail. Flexibly mounted with spinal nerves and dura mater of spinal cord. 11 cm; 0.15 kg

9982-1000151



9982-1005101

3B BONElike™ Vertebrae

Unique worldwide, original cast of human vertebrae with precise illustration of even the finest anatomical structures, shown with excellent quality.

- Feels and looks like real bones.
- Realistic weight.
- Each vertebra is marked for identification (C1-7, T1-12 and L1-5).

Set of 24 BONElike™ Vertebrae

This set includes the 7 cervical, 12 thoracic and 5 lumbar vertebrae. Each vertebra is labeled for identification purposes (C1-7, T1-12 and L1-5). Supplied in a transport and storage case with individual compartments for all 24 vertebrae.

41x40x12 cm; 2.4 kg

9982-1000156

3B BONElike™ Vertebral Column

Flexible, mounted, true-to-life model of the human vertebral column in excellent BONElike™ quality with exact reproduction of all anatomical details, based on real weight. Consists of the male pelvis and occipital bone. Occipital bone and atlas can be detached individually. Without stand, see 9982-1000132, page 18.

85 cm, 1.5 kg

9982-1000157

UNIQUE!



Set of 7 3B BONElike™ Cervical Vertebrae

Supplied on a base.
30x21x6 cm; 0.3 kg

9982-1000021

Set of 5 3B BONElike™ Lumbar Vertebrae

Supplied on a base.
30x21x6 cm; 0.3 kg

9982-1000155

» *"It is a unique reproduction of a bone that cannot be distinguished from a real one. One of my staff members, a world renowned bone specialist, was not able to distinguish the vertebra from a real one. I wish your company much success with your excellent artificial preparations."*
(Prof. Dr. Dr. h.c. Horst Erich König, Director of the Institute for Anatomy at the University of Veterinary Medicine, Vienna)

"In the first moment, I actually believed it was real bone! My compliments, the material has excellent tactile feel."
(Dr. med. Yvonne Kammerer, Institute of Anatomy of the University of Regensburg, Germany)

"I am convinced that you have developed the best bone ever created by man."
(Professor Vladimir Ovcharov, MD, DSc Rector of Medical University – Sofia)





9982-1000134

Pelvic Skeleton, Female

Consisting of hip bone, sacrum with coccyx and 2 lumbar vertebrae as well as movable symphysis. 19x25x24 cm; 0.9 kg

9982-1000134



9982-1000135

Pelvic Skeleton, Female, with Movable Femur Heads

Consisting of hip bone, sacrum with coccyx and 2 lumbar vertebrae as well as movable symphysis. 30x30x20 cm; 1.2 kg

9982-1000135



9982-1000285

Female Pelvis, 3-part

Three part model representing an original cast of a bony female pelvis, shows all the details of anatomical structures: Two hip bones, the pubic symphysis, the sacrum and the coccyx, the fifth lumbar vertebra with intervertebral disc. A midsagittal section through the fifth lumbar vertebra, sacrum and coccyx, allow both halves of the pelvis to be disassembled revealing a part of the cauda equina in the vertebral canal. The left half of the fifth lumbar vertebral body is removable.

19x27x19 cm, 0.9 kg

L/D/E/F/I/S/P/J/R/C www.

9982-1000285



9982-1000288

Female Pelvis with Ligaments, Vessels, Nerves, Pelvic Floor and Organs, 6-part

This six part model of a female pelvis represents detailed information about the topography of bones, ligaments, vessels, nerves, pelvic floor muscles and female pelvic organs. It presents the whole pelvic floor with partially removable midsagittally sectioned external anal sphincter, external urethral sphincter, deep and superficial transverse perineal and bulbospongiosus. Rectum, uterus with fallopian tubes ovaries and vagina are also removable and can be disassembled into 2 halves by midsagittal section. The right pelvic half demonstrates the divisions and topographical anatomy of the common iliac artery, the external and internal artery and also of the common iliac vein and the external iliac vein. The right sacral plexus, right sciatic nerve and right pudendal nerve are also shown. Bones and ligaments presented: Two hip bones, the pubic symphysis, the sacrum and the coccyx, the fifth lumbar vertebra with intervertebral disc. A midsagittal section through the fifth lumbar vertebra, sacrum and coccyx, allow both halves of the pelvis to be disassembled revealing a part of the cauda equina in the vertebral canal. The left half of the fifth lumbar vertebral body is removable. The right half of the model shows following pelvic ligaments: inguinal ligament, sacrotuberous ligament, sacrospinous ligament, anterior sacroiliac ligaments, iliolumbar ligament, anterior longitudinal ligament, interosseous sacroiliac ligament, posterior sacroiliac ligament and obturator.

19x27x19 cm, 1.6 kg

L/D/E/F/I/S/P/J/R/C www.

9982-1000288



9982-1000281

Female Pelvis, 2-part

41x31x20 cm; 2.2 kg

9982-1000281



9982-1000282

Male Pelvis, 2-part

41x31x17 cm; 2.5 kg

9982-1000282

Median section. One half of genital organs with bladder and rectum is removable, one half is shown at the normal position in the pelvis. Supplied on baseboard offering the possibility to be mounted to the wall.

L/E/D/S/F/P/I/J www.

UNIQUE!

Shoulder Joint with Rotator Cuff, 5-part

This model comprises the upper half of the humerus, the clavicle and the shoulder blade. The muscles of the rotator cuff are displayed and the sites of origin and insertion of the shoulder muscles are highlighted in colour (origin = red; insertion = blue). By removing the individual muscles, all movements of the shoulder joint can be performed. Mounted on a stand. 18x18x24cm; 0.85kg

L/E/D/S/F/P/I/J [www.](http://www.3b-bioscience.com)

9982-1000176

9982-1000176

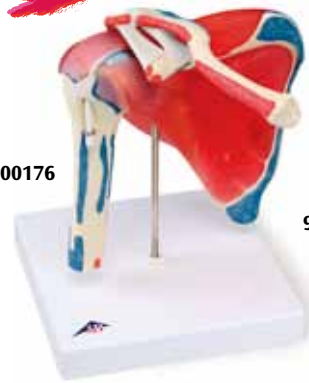

9982-1000178



Joints

Hip Joint, 7 part

This unique model shows the right hip joint of a male with the individual muscles as well as the muscle origins and insertions on the femur and the hip bone. For educational purposes, the origin and insertion areas of the muscles have been raised and presented in colour (muscle origin = red; muscle insertion = blue). The hip muscles have been mounted on their corresponding regions of origin and insertion and are thus removable. 18x32x18cm

L/E/D/S/F/P/I/J/R/C [www.](http://www.3b-bioscience.com)

9982-1000177



9982-1000177



9982-1000175

Knee Joint, 12-part

Completing our set of joints and their muscles we are proud to introduce this 12-part knee model. It shows different removable muscles and muscle portions of the knee area. Colour coded and raised areas indicate the muscle origin and insertion points on the femur, tibia, and fibula. In addition parts of the fibular and tibial collateral ligaments are represented. All the muscles of the leg are easily removable to permit study of the deeper anatomical layers.

33x17x17 cm, 0.9 kg

L/D/E/F/I/S/P/J/R/C [www.](http://www.3b-bioscience.com)

9982-1000178

Femoral Fracture and Hip Osteoarthritis

This model was developed to provide patients with understandable information, e.g. before surgery. It shows the right hip joint of an elderly person in half natural size. In addition, a frontal section through the femoral neck is shown in relief on the base. The model shows the femoral fractures that occur most commonly as well as typical wear and tear symptoms of the hip joint. The following fractures are shown: medial femoral neck fracture, lateral femoral neck fracture, fracture through the trochanteric region, fracture below the trochanters, femoral shaft fracture, femoral head fracture, fracture of the greater trochanter, fracture or avulsion of the lesser trochanter. Mounted on base.

14x10x22 cm; 0.3 kg

E/D/S/F/P/J [www.](http://www.3b-bioscience.com)

9982-1000175

Elbow Joint, 8 parts

This model shows the right elbow of a male with individual muscles and the muscular origins and insertions on humerus, radius and ulna. For didactic reasons, the areas of the muscular origins and insertions are raised and colour-coded (origin = red, insertion = blue). The muscles can be attached to and removed from the corresponding areas of origin and insertion. 25x41x25 cm

E/D/S/F/P/I/J [www.](http://www.3b-bioscience.com)

9982-1000179



9982-1000179

Sports Shoulder

Includes upper half of humerus, clavicle and scapula. Articulated to show normal movement. Depicts the following:

- M. supraspinatus,
- Long head tendon,
- Glenoid labrum,
- Rotator cuff

Stand included. 23x17x12 cm; 0.4 kg

E

9982-1000003



9982-1000003

9982-1002390



Deluxe Knee

Distal half of femur articulated to tibia, fibula and patella. Depicts all major muscles of the knee. Cruciate/collateral ligaments simulated with triple springs. Simulated "Bucket Handle" tear in medial meniscus. Patellar tendon simulated. Stand included.

33x12x12 cm; 0.7 kg

E

9982-1002390

Anatomical Model Human

3B Scientific® Joint Series

These functional models provide an accurate demonstration of the anatomy and mechanics of the major joints, allowing better doctor-patient or teacher-student understanding. Use these life size and fully flexible joints to demonstrate abduction, anteversion, retroversion, internal/external rotation and much more. Mounted on a stand.



Functional Shoulder Joint
Consists of shoulder blade, collar bone, portion of humerus and joint ligaments.
16x12x20 cm; 0.35 kg
9982-1000159

Functional Hip Joint
Consists of portion of femur, hip bone and joint ligaments.
17x12x33 cm; 0.55 kg
9982-1000161

Functional Knee Joint
Consists of portion of femur, tibia and portion of fibula; also includes meniscus, patella with quadriceps tendon and joint ligaments.
12x12x34 cm; 0.4 kg
9982-1000163

Functional Elbow Joint
Consists of portion of humerus, complete ulna and radius as well as joint ligaments.
12x12x39 cm; 0.5 kg
9982-1000165



Deluxe Functional Shoulder Joint Model
Consists of shoulder blade, collar bone and upper arm stump.
Mounted on a base. 22 cm; 0.41 kg
9982-1000160

Deluxe Functional Hip Joint Model
Consists of thigh stump and hip bone. Mounted on a base.
32 cm; 0.56 kg
9982-1000162

3B Scientific® Deluxe Functional Joint Models

These high quality functional models of a lifesized right joint with ligaments shows the anatomy and natural physiological movements (e.g. abductions, anteversion, retroversion, internal and external rotation) in exceptional detail. The colour of the natural cast bones is extremely realistic. The cartilage on the joint surfaces is marked in blue. Mounted on a base.

L/E/D/S/F/P/I/J

Deluxe Functional Knee Joint Model
Consists of thigh stump, shinbone stump and calf bone stump, menisci and patella. Mounted on a base.
32 cm; 0.55 kg
9982-1000164

Deluxe Functional Elbow Joint Model
Consists of a stump of the upper arm, ulna and radius. Mounted on a base. 33 cm; 0.285 kg
9982-1000166

3B Scientific® Mini Joint Series

Following in the footsteps of their successful larger brothers, these mini-joints have been reduced to a half their natural size but have kept all of their functionality. In addition to the external anatomical structures, using the superb new joint cross-sections mounted on base, the medical or teaching professional now has the ability to explain what is happening "within".

Also available without base:

Mini Hip Joint
16.5x8.5x9 cm; 0.1 kg
9982-1000167

Mini Shoulder Joint
12x10x5 cm; 0.05 kg
9982-1000171

Mini Knee Joint
20x6.5x5 cm; 0.13 kg
9982-1000169

Mini Elbow Joint
17.5x4x3.5 cm; 0.05 kg
9982-1000173

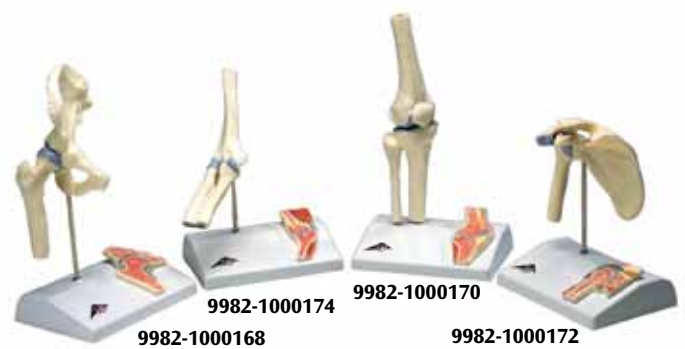

Mini Hip Joint with Cross Section
With base. 16x12x20 cm; 0.2 kg
9982-1000168

Mini Elbow Joint with Cross Section
With base. 16x12x20 cm; 0.2 kg
9982-1000174

Mini Knee Joint with Cross Section
With base. 10x14x24 cm; 0.35 kg
9982-1000170

Mini Shoulder Joint with Cross Section
With base. 12x14x16 cm; 0.2 kg
9982-1000172

**BEST
SELLER**



9982-1000206

Dual Sex Muscle Figure, 45-part

The finest teaching tool available! Standing over 138 cm tall, this ¾ life size human replica depicts deep and superficial musculature in addition to the body's major nerves, vessels, tissues and organs in exquisite detail. The internal organs are removable (45 pieces in all) to reveal the fundamental inter-relationships of human morphology. Remove the calvarium to view the 3-part removable brain. Look beneath the liver to reveal the gall bladder and bile duct. Peer inside the appendix, stomach lungs, heart or kidney. Remove and view the details of 13 different muscles of the arms and legs. This dual sex version has interchangeable genital inserts and a female mammary gland as well as a detailed multilingual key card identifying the hand numbered structures. Over 600 hand numbered and identified structures. Hand painted in realistic colours and mounted on a convenient roller base.

Includes the following features:

- 5 arm / shoulder muscles
- 8 leg / hip muscles
- 2-part removable heart
- 5-part head including removable brain
- 2-part removable lungs
- 2-part stomach
- Removable 4-part male and 2-part female genital inserts

Detachable arms, leg, head, and abdominal wall for detailed study
138x50x32 cm; 12.4 kg

L/D/E/F/S/P/I/J www.3b.com

9982-1000206

Muscular Figure, 1/3 life-size, 2-part

Mini muscle model's (57 cm) appeal is its value for money. All the superficial musculature of the human form is accurately reproduced and detailed in life like colours in this desktop size version. The chest plate is removable to reveal the internal organs and the right side contains a female mammary gland. Over 125 hand numbered and identified structures. Delivered on base.

57x25x18 cm; 2.1 kg

L/D/E/F/S/P/I/J www.3b.com

9982-1000212



9982-1000212



9982-1000210 / 9982-1000211

Complete Dual Sex Muscular Figure, with Internal Organs, 33-part

The whole human anatomy in a convenient size. This 84 cm high version of our deluxe muscle figure is a perfect choice for thorough demonstrations of human musculature and internal organs where space is an issue. Exquisitely hand detailed and complete with 33 removable and/or dissectible parts, this version represents fine quality at a more affordable price. Painted by hand in realistic colours, this model comes complete with stand and detailed multilingual product manual.

It includes the following features:

- 5 arm/shoulder muscles
- 8 leg/hip muscles
- 2-part removable heart
- 2-part removable brain
- 2 Removable lungs
- Removable 2-part male and 2-part female genital inserts
- Detachable arm and abdominal wall for detailed study
- Almost 400 hand numbered and identified structures

84x30x30 cm; 5.0 kg

L/D/E/F/S/P/I/J [www.](http://www.3BScientific.com)

9982-1000210

Complete Female Muscular Figure, 21-part

The whole human anatomy in a convenient size without internal organs or male genital inserts for where space is an issue. This model comes complete with stand and detailed multilingual product manual. It includes the following features:

- 5 arm/shoulder muscles
- 8 leg/hip muscles
- Detachable arm and abdominal wall for detailed study
- Over 400 hand numbered and identified structures

84x30x30 cm; 5.0 kg

L/D/E/F/S/P/I/J [www.](http://www.3BScientific.com)

9982-1000211

9982-1000015



Dissectable Muscled Arm, 6-part

This model illustrates both the superficial and deeper muscles, five of which are removable. Tendons, vessels, nerves and bone components of the left arm and shoulder are shown in great detail. Parts are accurately numbered. Delivered on removable stand.

60x18x18 cm; 1.9 kg

L/D/E/F/S/P/I/J [www.](http://www.3BScientific.com)

9982-1000015

9982-1000353



Lower Muscled Leg with Knee, 3-part

This life size model can be divided horizontally at the knee joint for viewing the joint structures. The gastrocnemius muscle can be detached. Supplied on a base.

58 cm; 2.6 kg

L/D/E/F/S/P/I/J [www.](http://www.3BScientific.com)

9982-1000353

9982-1000213

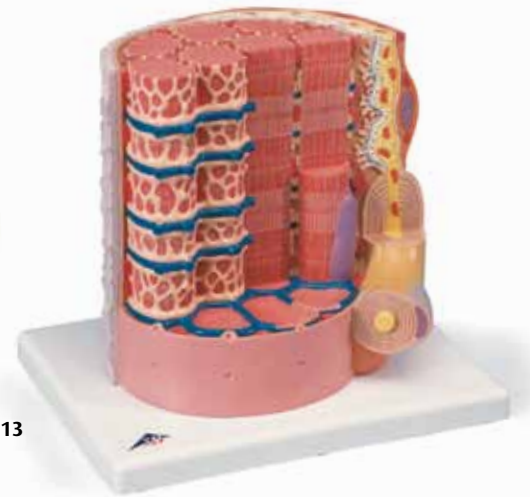

3B MICROanatomy™ Muscle Fibre

The model illustrates a section of a skeletal muscle fibre and its neuromuscular end plate magnified approx. 10.000 times. The muscle fibre is the basic element of the diagonally striped skeletal muscle.

23.5x26x18.5 cm; 1.1 kg

L/E/D/S/F/P/I/J

9982-1000213

3B Scientific® Torsos

Torsos with musculature, life-size or smaller, for secondary education or for medical training: if top-quality human torso-models are important to you, then 3B Scientific is exactly the right choice for you! Our torsos are developed in close coordination with anatomy professors and doctors, and are made in Germany by highly specialised model builders with high quality, toxicologically harmless materials. Since this practice is unfortunately not the case with all manufacturers, consider your health and that of your students and patients and ensure that you are ordering anatomical models with harmless components by asking for an independent study guaranteeing the same.

We were the first manufacturer to order a long term study of one of our models (Torso 9982-1000190) to be examined to verify the safety of our materials. This study was carried out by the TÜV (the nationally recognized independent German inspection organisation). A report of the results can be found on our webpage www.3bscientific.com/downloads.html.

Because hands-on training tools should not only be vivid and thrilling but also safe!

Whether you choose from the Classic Series, the Luxury Series or one of our special versions, every 3B Torso is:

- developed and modelled in Germany
- accurately manufactured from high quality, harmless materials
- painted by hand true to natural detail

And Classic and Luxury Torsos come with our detailed 3B Scientific® Torso Guide (9982-1000183) including a CD-ROM.

9982-1000190

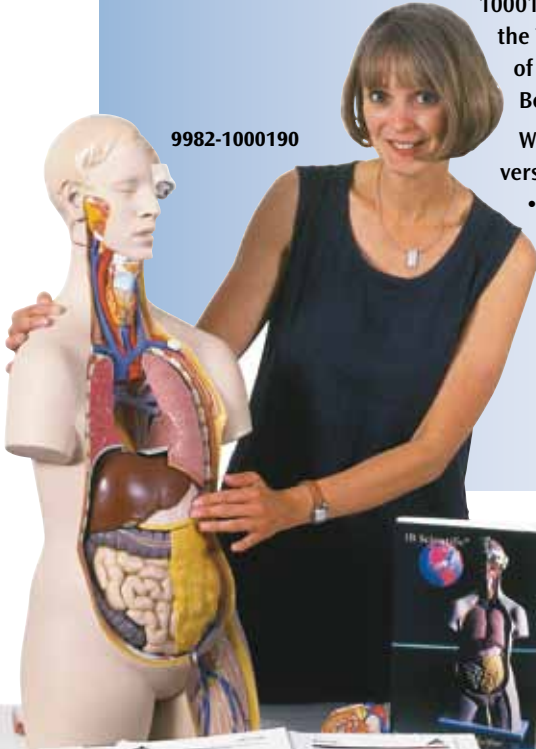

BEST SELLER

9982-1000183

9982-1000184

3B Torso Classroom Set

Includes 33 brilliant overhead foils with coloured pictures of each part of the torsos.

9982-1000184

Classic Unisex Torso, 14-part

This popular school torso is supplied with the following removable parts:

- 3-part head
- 2 lungs
- 2-part heart
- Stomach
- Liver with gall bladder
- 2-part intestinal tract
- Front half of kidney
- Front half of urinary bladder
- Supplied with 3B Torso Guide.

87x38x25 cm; 5.9 kg

9982-1000190

3B Torso Guide

- Brilliant coloured pictures of each part of the torsos
- Even the smallest structures are explained
- Valuable teaching tips to create more interesting lessons
- Complete with 7 different languages (Latin, English, German, Spanish, Portuguese, French, Japanese)
- Also on a CD-ROM in pdf format to assist in creating tests or preparing lessons
- Supplied complete in a coloured filing system.

9982-1000183

Classic Unisex Torso, 12-part

The following components of this torso are removable:

- 2-part head
- 2-part removable heart
- 2 lungs
- Stomach
- Liver with gall bladder
- 2-part intestinal tract
- Front half of kidney
- Supplied with 3B Torso Guide.

87x38x25 cm; 4.6 kg

9982-1000186

Classic Unisex Torso, 11-part

(not shown)

Same as 9982-1000190, but without head.

Supplied with 3B Torso Guide.

70x38x25 cm; 5.5 kg

9982-1000189

Classic Unisex Torso, 10-part

(not shown)

Same as 9982-1000186, but without head. Supplied with 3B Torso Guide.

70x38x25 cm; 4.1 kg

9982-1000187

BEST SELLER

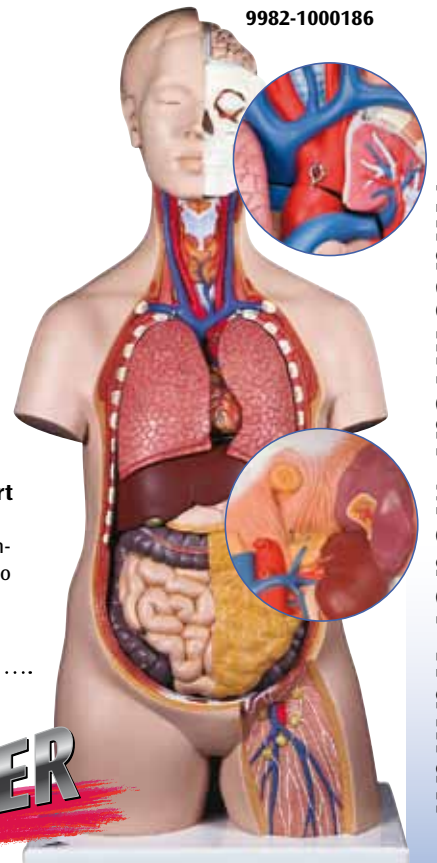

9982-1000186

Classic Unisex Torso with Opened Neck and Back, 18-part

Based on our 9982-1000190 torso, this model is characterised by its open neck and back section reaching from the cerebellum to the coccyx. Vertebrae, intervertebral discs, spinal cord, spinal nerves, vertebral arteries, and many other features are represented in detail and can be studied closely. It contains the following new features additionally to 9982-1000190:

- 7th thoracic vertebra removable
- 6-part head
- Supplied with 3B Torso Guide (page 27)

87x38x25 cm; 5.8 kg
9982-1000193



9982-1000193



9982-1000188

Classic Unisex Torso, 16-part

This torso is especially popular with students. It shows the human anatomy in great detail and contains the following removable parts:

- 3-part head
- 2 lungs with sternum and rib attachments
- 2-part heart
- Stomach
- Liver with gall bladder
- 4-part intestinal tract
- Front half of kidney
- Front half of urinary bladder
- Supplied with 3B Torso Guide (page 27).

87x38x25 cm; 6.8 kg

9982-1000188

Overview: Classic-Torsos

Product Number	9982-1000187	9982-1000189	9982-1000186	9982-1000190	9982-1000188	9982-1000193
Parts	10	11	12	14	16	18
Open Back	–	–	–	–	–	yes
Head	–	–	2-part	3-part	3-part	6-part
Lungs	yes	yes	yes	yes	yes	yes
Rib Representation	–	–	–	–	yes	–
Heart	2-part	2-part	2-part	2-part	2-part	2-part
Stomach	1-part	1-part	1-part	1-part	1-part	1-part
Liver/Gall Bladder	yes	yes	yes	yes	yes	yes
Intestinal Tract	2-part	2-part	2-part	2-part	4-part	2-part
Half Kidney	yes	yes	yes	yes	yes	yes
Half Urinary Bladder	–	yes	–	yes	yes	yes

Unisex Torso with Fixed Head, Back and Shoulder Opened, 17-part

Its neck and back section is opened from the 1st cervical to the 3rd lumbar vertebra and its left shoulder is opened to reveal part of the shoulder blade and part of the humerus. The following parts are made of hard plastic and removable:

- Eyeball with optic nerve
- Brain half
- 2 lungs
- 2-part heart
- 2-part stomach
- Liver with gall bladder
- Intestinal tract
- Front half of kidney
- 1 cervical vertebra, 1 thoracic vertebra, lumbar vertebra
- Pancreas with duodenum
- Front half of bladder

92x42x25 cm; 13.6 kg

L/D/E/F/S

9982-1001238

Unisex Torso with Fixed Head, 11-part (not shown)

- Eyeball with optic nerve
 - 2 lungs
 - 2-part heart
 - 2-part stomach
- Liver with gall bladder
Intestinal tract
Front half of kidney
Closed back and shoulders

L/D/E/F/S

9982-1008541

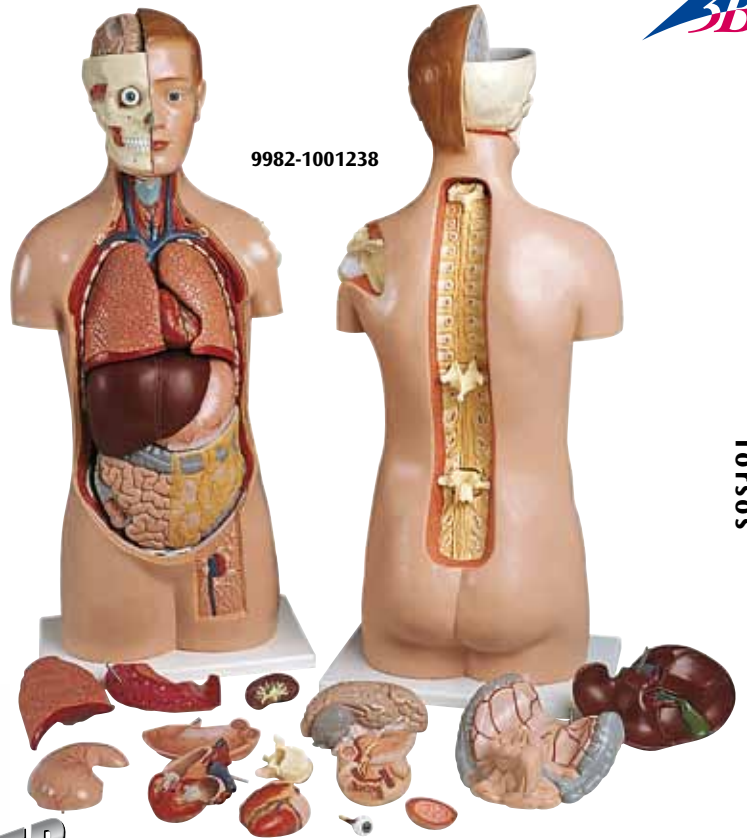

9982-1001238

TORSOS



9982-1000202



9982-1000199

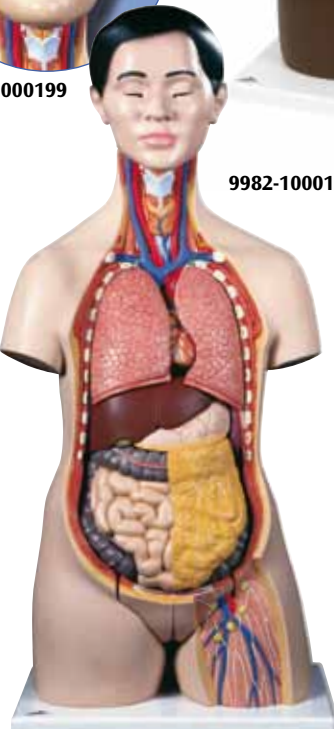

9982-1000198

Asian and Japanese Dual Sex Torsos, 18-part

3B Scientific has developed two torsos especially for Asian schools. Both are judged as a "must" by the Japanese Ministry of Health for high quality education. Choose between general Asian or specifically Japanese facial features, the internal organs are soft and identical in both versions:

- Head
- 2 lungs
- 2-part heart
- Stomach
- Liver with gall bladder
- 2-part intestinal tract
- Front half of kidney
- 3-part female genital insert with embryo
- 4-part male genital insert
- Supplied with 3B Torso Guide (page 27).

85x38x25 cm; 6.7 kg

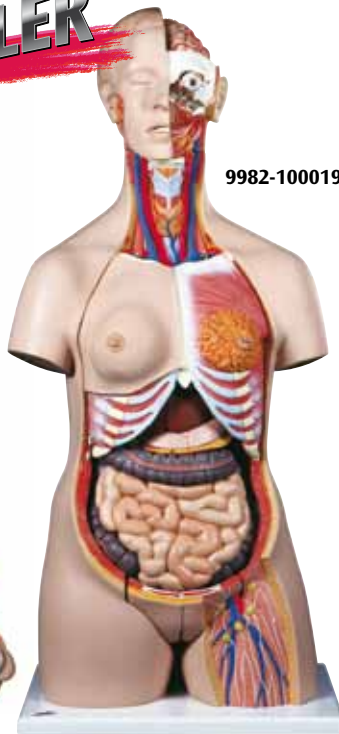

9982-1000196

Deluxe Dual Sex Torso, 24-part

The advanced torso version! Same as 9982-1000197, additionally featuring:

- 3-part head
- 2-part stomach
- 4-part intestinal tract
- Supplied with 3B Torso Guide (page 27).

87x38x25 cm; 7.5 kg

9982-1000196

African Dual Sex Torso, 24-part

Same as 9982-1000196.

87x38x25 cm; 7.5 kg

L/D/E/F/S/I/J/R/C www.3bscientific.com

9982-1000202

Japanese Dual Sex Torso, 18-part

9982-1000199

Asian Dual Sex Torso, 18-part

9982-1000198

Anatomical Model Human



9982-1000204

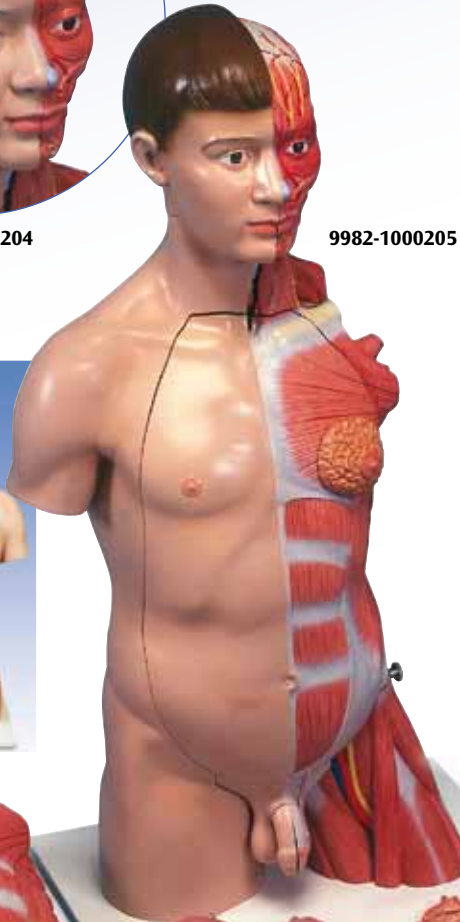

9982-1000205



Deluxe Dual Sex Torso with Muscular Arm, 33-part

A unique feature of this life-size torso is the removable 6-part muscle arm. The high quality model therefore fully represents the anatomy of the complete human upper body. The right half shows the skin, the left half the superficial and deeper muscles with nerves, vessels and bony structures. The following parts are removable:

- 2-part head
- Brain half
- Sternocleidomastoideus muscle
- 6-part muscle arm, removable
- Upper leg stump
- Chest /abdominal wall with detachable mammary gland
- Torso body
- 2 lungs
- 2-part heart
- Liver with gall bladder
- 2-part stomach
- Kidney half
- 4-part intestinal tract
- 3-part female genital insert with embryo
- 4-part male genital insert
- Supplied on base board and with 3B Torso Guide (page 27).

90x55x60 cm; 15.5 kg

L/D/E/F/S/P/J in colour

9982-1000205

Asian Deluxe Dual Sex Torso with Muscular Arm, 33-part

Same as 9982-1000205, with Asian head.

9982-1000204



Overview: Deluxe Torsos

Product Number	9982-1000196	9982-1000198	9982-1000199	9982-1000202	9982-1000205
Parts	24	18	18	24	33
Muscular arm	–	–	–	–	6-part
Open Back	–	–	–	–	–
Female Breast Covering	1-part	1-part	1-part	1-part	2-part
Head	3-part	1-part	1-part	3-part	3-part
Lung Halves	yes	yes	yes	yes	yes
Ribs Shown	yes	yes	yes	yes	yes
Heart	2-part	2-part	2-part	2-part	2-part
Stomach	2-part	1-part	1-part	2-part	2-part
Liver/Gall Bladder	yes	yes	yes	yes	yes
Intestine	4-part	2-part	2-part	4-part	4-part
Kidney Half	yes	yes	yes	yes	yes
Male Genitals	4-part	4-part	4-part	4-part	4-part
Female Genitals	3-part	3-part	3-part	3-part	3-part

Disc Torso, 15 slices

This unique torso is horizontally sectioned into 15 slices. The topographical relationships are represented as coloured reliefs on the individual sectional planes. For closer study, each disc can be shifted horizontally, rotated around its sagittal axis, and individually removed.

130x40x35 cm; 11.5 kg

L/D/E/F/S

9982-1001237

Mini Torso without Head,

9-part (not shown)

Same features as 9982-1000195, but without a head.

42x24x18 cm; 1.9 kg

L/D/E/F

9982-1000194

Mini Torso 12-part

This torso is approximately half life size. Even small hands can quickly disassemble it, removing:

- 2-head halves
- Brain half
- 2 lungs
- 2-part heart
- Stomach
- Liver with gall bladder
- 2-part intestinal tract

54x24x18 cm; 2.0 kg

L/D/E/F

9982-1000195

BEST SELLER

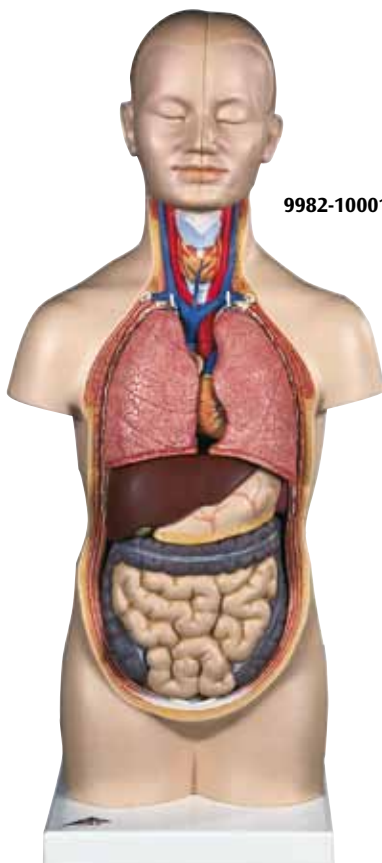

9982-1000195

Look for our large selection of Charts starting on page 154.

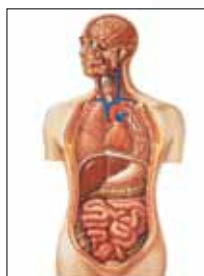

9982-1001237

Our complete product line can be found on www.3bscientific.com



9982-1000220

9982-1000219

Median and Frontal Section of the Head

2 relief models on baseboard.
41x31x5 cm; 1.45 kg

L/D/E/F

9982-1000220

Median Section of the Head

This relief model shows all relevant structures of the human head in great detail. On baseboard.

26x33x5 cm; 1.0 kg

L/D/E/F

9982-1000219



9982-1000221

Half Head with Musculature

Representation of the outer, superficial and the internal (median section) structures of head and neck. Delivered on removable stand.

22x18x46 cm; 1.1 kg

L/D/E/F

9982-1000221



9982-1000241

9982-1000243

9982-1000244

9982-1000240

9982-1000239

9982-1000242



9982-1001247

Adult Dentures

Tooth roots, spongiosa, vessels, and nerves are exposed. The lower jaw is movable. On base.

16x12x13 cm; 0.9 kg

L/D/E/F/S

9982-1001247

Classic Tooth Model Series, 5 models

This series shows 5 representative types of adult dentition individually mounted on removable stands:

- 2-part lower incisor with longitudinal section (9982-1000240)
- 2-part lower canine with longitudinal section (9982-1000241)
- Lower single root pre-molar (9982-1000242)
- 2-part lower twin root molar with longitudinal section showing caries attack (9982-1000243)
- 3-part upper triple root molar with longitudinal section and caries insert (9982-1000244)

Also available individually.

23 – 29 cm; 2.0 kg

L/D/E/F

9981-1000239

Art. No.	Description
9982-1000240	Lower Incisor, 2-part
9982-1000241	Lower Canine, 2-part
9982-1000242	Lower Single Root Pre-Molar
9982-1000243	Lower Twin-Root Molar Showing Caries Attack, 2-part
9982-1000244	Upper Triple Root Molar, 3-part

Dental Disease, magnified 2 times, 21 parts

With 16 removable adult teeth magnified two times. One half of the model shows eight healthy teeth and healthy gums. The other half of the model shows the following dental diseases:

- Dental plaque
- Dental calculus (tartar)
- Periodontitis
- Inflammation of the root
- Fissure, approximal and smooth surface caries.

One part of the front bone section can be removed to view the roots, vessels and nerves. Two molars are sectioned along the length to show the inside of the tooth.

Delivered on a base.

25.5 x 18.5 x 18cm; 0.6 kg

E/D/F/S/P/I/J www.3b.com

9982-1000016



9982-1000016

Giant Dental Care Model, 3 times life-size

This model, large enough to be seen from the back of a classroom, shows the upper and lower half of an adult's dentition. A flexible joint between the jaws allows easy movement. Teach children proper cleaning techniques using the giant toothbrush included with this model.

18x23x12 cm; 1.5 kg

9982-1000246

Replacement Parts for 9982-1000246

Giant Toothbrush

36.5 cm

9982-4000098



9982-1000246

9982-4000098

Dentition Development

Cast from a natural specimen, 4 upper and lower jaw halves, 4 different stages of development:

- New born
- Approx. 5-year old child
- Approx. 9-year old child
- Young adult

33x10x20 cm; 0.5 kg

L/D/E/F

9982-1000248



9982-1000248



9982-1000222

Brain, 2-part

A medially divided brain, perfect for beginning studies because of its affordable price. Delivered on removable base.

15x14x17.5 cm; 0.7 kg

L/D/E/F/S/P/I/J www.3b.com

9982-1000222

BEST SELLER

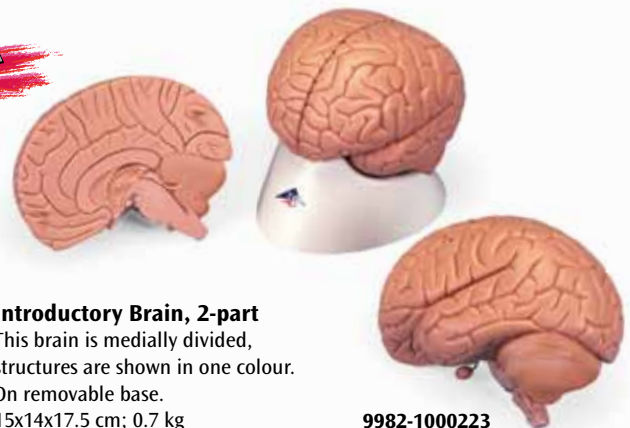

Introductory Brain, 2-part

This brain is medially divided, structures are shown in one colour. On removable base.

15x14x17.5 cm; 0.7 kg

9982-1000223

9982-1000223



9982-1000226

9982-1000226
disassembled

9982-1008552

Classic Brain, 5-part

This midsagittally sectioned model is an original anatomic cast of a real human brain. The components of its left half are:

- Frontal and parietal lobe
- Temporal and occipital lobe
- Encephalic trunk
- Cerebellum

Matches skull models 9982-1000046, 9982-1000050, 9982-1000050, 9982-1000052, 9982-1000053, 9982-1000054, 9982-1000055, 9982-1000056.

On removable base.

13x14x17.5 cm; 0.49 kg

L/D/E/F/S/P/I/J [www.](http://www.3BScientific.com)

9982-1000226

Brain with Arteries, 5-part

Medially divided with the right half showing arteries. The left half can be disassembled into:

- Frontal with parietal lobes
- Temporal with occipital lobes
- Half of brain stem
- Half of cerebellum

On removable stand.

15.5x13x15 cm; 1.0 kg

L/D/E/F/S

9982-1008552

Neuro-Anatomical Brain, 8-part

This deluxe brain is medially divided. On the right half, you will find a coloured, systematic grouping and representation of the cerebral lobe. The left half shows:

- Pre and post-central region
- Broca and Wernicke areas
- Heschl's gyrus
- Brain nerves
- Ventricles

Both halves can be disassembled into:

- Frontal with parietal lobes
- Temporal with occipital lobes
- Half of brain stem
- Half of cerebellum

On removable base.

14x14x17.5 cm; 0.95 kg

L/D/E/F

9982-1000228



9982-1000230

Rat Brain Comparative Anatomy

The model shows a rat brain in approx. 6-fold enlargement. Sectioned medially, it can be disassembled into two halves. The right half of the model shows the structures of the cerebrum, cerebellum and brain stem, each of which is colour-coded for didactic purposes (cerebrum = pink, cerebellum = blue, brain stem = yellow), both externally and in the median section. The left half of the model is largely transparent, thus revealing a view of the coloured left lateral ventricle and hippocampus, which can also be seen in the median section. For purposes of comparison, a natural cast of a rat brain and a didactic, small scale illustration of a human brain in median section are shown on the base, with the same colour coding used for the various regions.

14x10x16 cm; 0.24 kg

L/D/E/F/S/P/I/J [www.](http://www.3BScientific.com)

9982-1000230



9982-1000228

Nervous System, 1/2 life-size

This relief model shows a schematic representation of the central and peripheral nervous system. An excellent model to study the structure of the human nervous system. Supplied on baseboard.

80x33x6 cm; 3.5 kg

L/E/D/S/F/P/I/J [www.](http://www.3BScientific.com)

9982-1000231



9982-1000231

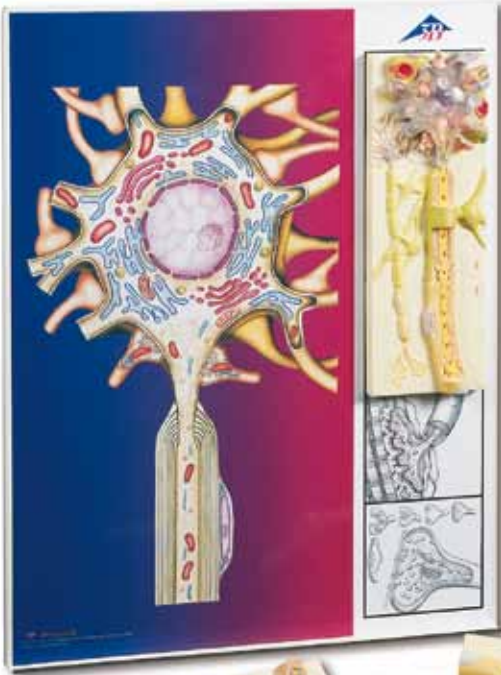

9982-1000233

9982-1000234

9982-1000235

9982-1000232

9982-1000237

9982-1000236



9982-1000238

Spinal Cord with Nerve Endings

The model illustrates the composition of the spinal cord, magnified to a scale of about 5:1. The spinal cord is formed by a central channel surrounded by "grey matter" with an outer layer of "white matter". The base features illustrations of various cross sections through the white and grey matter at the neck, torso, lumbar and sacral regions. Supplied on a base. 26x19x13 cm, 0.4 kg

L/D/E/S/F/P/I/J www.3b.com

9982-1000238

Motor Neuron Diorama

Magnified more than 2,500 times, this model represents a fully three dimensional reproduction of a motor nerve cell situated within a milieu of interacting neurons and a skeletal muscle fibre. The membranous envelope has been cut away from the neuron to expose the cytological ultra-structure, organelles and inclusions within the cell body. Branching dendrites, communicating synapses and a myelin wrapped axon with node of Ranvier, project from the neuronal surface. A section of the axon lifts off to let you view the tightly wound layers of the enveloping myelin sheath and neurolemma, as well as the Schwann cell which formed them. Mounted on a wooden base.

43x20x28 cm; 3.0 kg

E

9982-1005553

"Physiology of Nerves" Series, 5 Magnetic Models on Illustrated Metal Board

Displaying the basic structures of the human nervous system. Each of the five sections shows a plastic coloured relief model of the main synapse variations. All sections can magnetically attach to the illustrated base which depicts the neural components in vivid colours. Each section is also available separately.

68x51x10 cm; 4.2 kg

E/D/S/F/P www.3b.com

9982-1000232

Neuron Cell Body

Typical neuron body with cell organelles, for example mitochondria and many other characteristics of human cell, are visible through a removable transparent cover. The edge of the cell body also shows the synapses of connected neurons.

12.2x11.7x6.2 cm; 0.2 kg

9982-1000233

Myelin Sheaths of the CNS

This model shows the glial cells which build the insulating layer around the axons of the central nervous system.

12.2x11.7x3.6 cm; 0.2 kg

9982-1000234

Schwann Cells of the PNS

Depicts a Schwann cell with sectioned core.

12.2x11.7x3.2 cm; 0.2 kg

9982-1000235

Motor End Plate

Neuromuscular junction with striated muscle fibre is depicted.

12.0x11.5x3.2 cm; 0.2 kg

9982-1000236

Synapse

Featuring the endoplasmic reticulum, mitochondria and the membranes of the synaptic gap. Also depicts 5 smaller relief models of the main synapse variations.

12.0x11.5x2.7 cm; 0.2 kg

9982-1000237

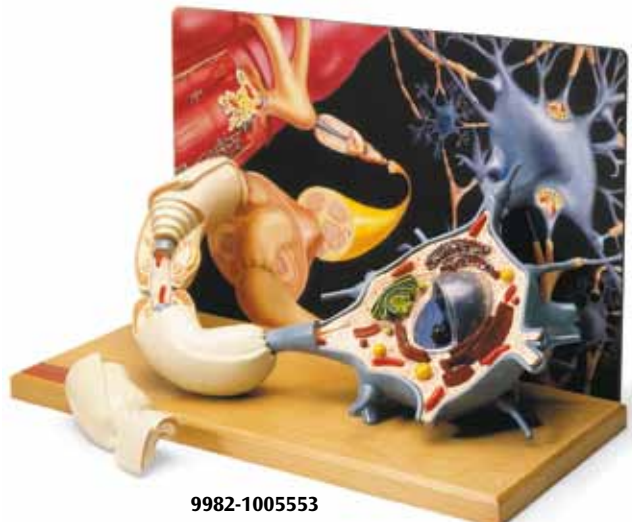

9982-1005553

BEST SELLER



9982-1000255

9982-1000257

Eye, 5 times full size, 6-part

Removable parts include:

- Upper half of the sclera with cornea and eye muscle attachments
- Both halves of the choroid with iris and retina
- Lens
- Vitreous humour

On base.

13x14x21 cm; 0.6 kg

L/E/D/S/F/P/I/J www.3bscientific.com

9982-1000255

Eye, 5 times full size, 8-part

Shows eyelid, lachrymal system, and other features around the eyeball, otherwise the same as 9982-1000255. On base of bony orbit.

20x18x21 cm; 1.2 kg

L/D/E/F

9982-1000257



9982-1000259

BEST SELLER



9982-1000258

Eye, 5 times full size, 6-part

This model dissects into:

- Both halves of sclera with cornea and eye muscle attachments
- Both halves of the choroid with iris and retina
- Lens
- Vitreous humour

On base. 9x9x15 cm; 0.1 kg

L/E/D/S/F/P/I/J www.3bscientific.com

9982-1000259

Eye, 3 times full size, 7-part

As 9982-1000259, but additionally with the optic nerve in its natural position in the bony orbit of the eye (floor and medial wall). On base.

18x26x19 cm; 1.1 kg

L/D/E/F

9982-1000258

Functional Eye

With this model the functions of the human eye can be taught very effectively. By moving the retina, the shape of the eye can be changed. The lens and ciliary body are made of silicone to allow the change of form and thickness of the lens. Pictures can be projected on the retina that allows you to demonstrate:

- Accommodation of the lens
- Near point of vision
- Myopia (near sightedness)
- Hypermetropia
- Presbyopia
- How to correct these problems with glasses

Supplied with detailed instruction manual.

45x30 cm; 2.0 kg

E

9982-1005046

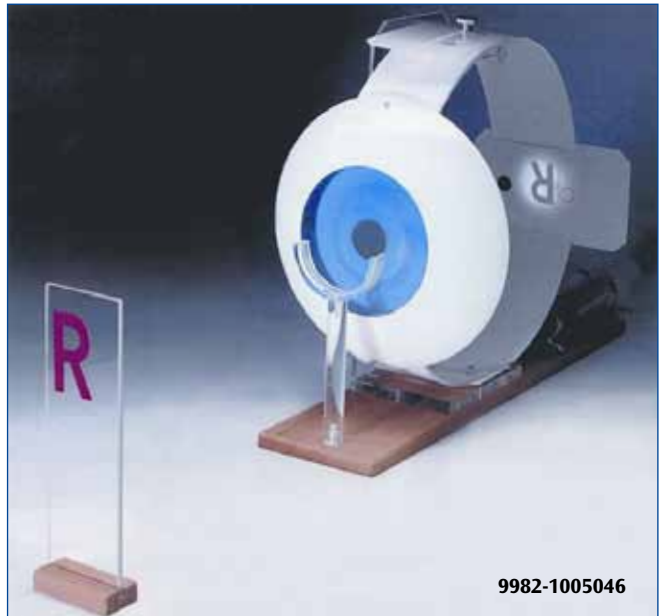

9982-1005046

Sensory Organs

Functional Eye – Small Version

Same features as model 9982-1005046.

32x18 cm; 1.5 kg

E

9982-1005047



9982-1005047

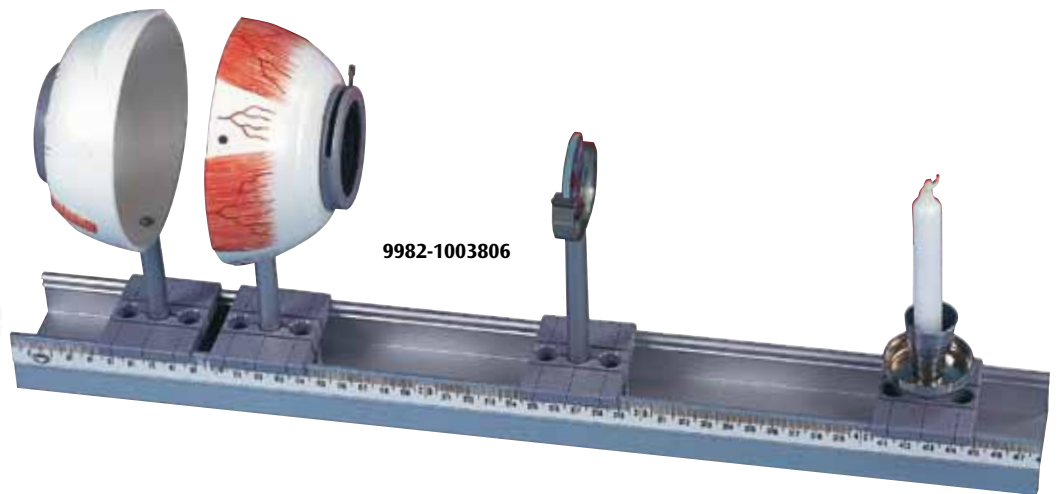

9982-1003806

Physical Eye Model

This model can be used to demonstrate the optical functions of the eye, e.g. representation of an object on the retina, accommodation (change in the lens curvature), short sightedness and far sightedness.

The model comprises:

- Half eyeball with adjustable iris diaphragm, lens holder and 2 convex lenses ($f = 65 \text{ mm}$ and 80 mm), on a rod
- Half eyeball with retina (transparent screen), on a rod
- Lens holder with one concave and one convex corrective lens, on a rod
- Candle holder with 2 candles, on a rod
- Aluminium rail, 50 cm long, with 4 clamp slides
- Storage case

49x5.5x18 cm; 2.0 kg

D

9982-1003806



3B MICROanatomy™ Eye

This model illustrates the microscopic structure of the retina with choroid and sclera. The left block like, layered side of the model side shows the complete structure of the retina including the vascular layer and parts of the sclera from a light microscopic view. The right part of the model is a sectional enlargement. It shows the microscopic structure of the photoreceptors and the cells of the pigmented layer.

25x23x18.5 cm; 1.2 kg

L/D/E/F/S/P/I/J www.3b.com

9982-1000260



9982-1000260

Anatomical Model Human



9982-1000250

Ear, 3 times life size, 4 part
Representation of outer, middle and inner ear. Removable eardrum with hammer, anvil and stirrup as well as 2-part labyrinth with cochlea and auditory /balance nerve. On base.
34x16x19 cm; 1.25 kg
L/E/D/S/F/P/I/J [www.](http://www.3BScientific.com)
9982-1000250

Organ of Corti

The model shows a three dimensional section through the organ of Corti, the site of the sense of hearing in the inner ear in humans. Special attention has been given to the detailed representation of the individual cellular components and membranes. The overview model in the foreground also shows the exact location of the organ in the cochlea.

26x19x26 cm, 1.0 kg
L/E/D/S/F/P/I/J

9982-1010005

NEW



9982-1010005



9982-1000253

Life size Auditory Ossicles

The human auditory ossicles, both individually and connected in natural position, embedded in transparent plastic.

9982-1000253

Desktop Ear Model, 1.5 times enlarged

Representation of the outer, middle, and inner ear. On base.

14x10x14.7 cm; 0.35 kg
L/E/D/S/F/P/I/J [www.](http://www.3BScientific.com)

9982-1000252



9982-1000252

NEW



Pressure equalisation in the middle ear

Functional model according to Bischof. This functional model shows the pressure equalising mechanism of the middle ear via the auditory tube. If there is a change in pressure in the tympanic cavity – for example if there is a rapid change in altitude – the eardrum curves outwards or inwards. The Eustachian tube equalizes the pressure with the help of the mechanical swallowing process. In the model, the bulging out or denting in of the eardrum and the subsequent equalisation of the pressure are demonstrated. Delivered with replacement membrane and teachers' manual.

16x13x12 cm, 0.2 kg
D/E

9982-1012829



9982-1005052

Functional Ear Model

This model shows how the tympanic membrane, ossicles, the complex internal ear with the cochlea and the oscillations of the basilar hearing membrane operate/interact. The enclosed mirror enables operation of the model for the studying of various ear functions from different angles at the same time. One single model may be studied by several students simultaneously in an action oriented learning situation. Includes a four colour explanatory chart.

30x20x15 cm; 1.0 kg
E

9982-1005052



9982-1000289

Skin Section, 70 times full-size

This relief model shows a section through the three layers of the hair-covered skin of the head.

Delivered on base it shows:

- Representation of hair follicles with sebaceous glands
- Sweat glands
- Receptors
- Nerves
- Vessels

26x33x5 cm; 1.0 kg

L/E/D/S/F/P/J [www.](#)

9982-1000289

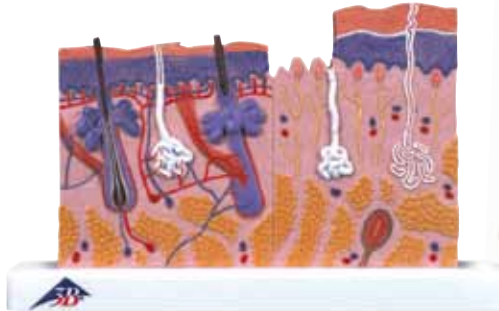

9982-1000290

Skin Section, 40 times full-size

The two halves of this relief model show the three layers of hairy and hairless skin in order to make the differences clear. In detail with hair follicles, sebaceous glands, sweat glands, receptor, nerves and vessels. Delivered on base.

24x15x3.5 cm; 0.2 kg

L/E/D/S/F/P/J [www.](#)

9982-1000290

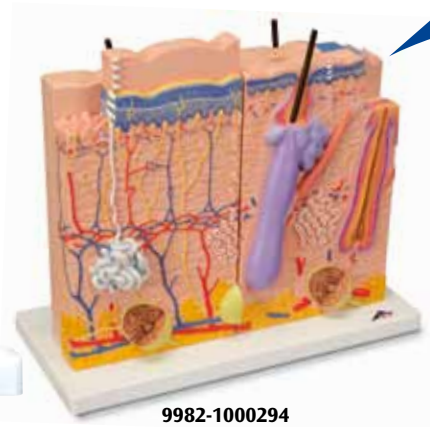

9982-1000294

3-part Skin Model

The model consists of three individual parts on a common stand that represent sections of the human skin with a magnification of 80x. Anatomical differences of the skin sections are didactically represented in an understandable manner. Microanatomical representation of the papillary layer (e.g. localised in the palm of the hand). Microanatomical representation of the reticular layer (e.g. localised at the back of the hand). Longitudinal section through the human scalp with hair follicle and root sheath. All layers making up the skin and microscopic structures such as nerve, vessels and tactile corpuscles have been accurately and spatially realised on the models.

L/E/D/S/F/P/J/C/R [www.](#)

9982-1000294

Skin Section

This model shows the microscopic structure of the skin in great detail. With the help of the different skin sections of the hairless skin (for example palm of hand) and the hairy skin (for example forearm) the different cell layers as well as the embedded sweat glands, touch receptor, blood vessels, nerves and a hair with root can be seen. Furthermore a nail section model on the base shows the nail plate, nail bed and the nail root. The representation of a hair root with all its cell layers completes the skin model.

10x12.5x14 cm; 0.35 kg

L/E/D/S/F/P/J [www.](#)

9982-1000292



9982-1000292



9982-1000291

Skin, Block Model, 70 times full-size

This unique model shows a section of human skin in three dimensional form. Individual skin layers are differentiated, and important structures such as hair, sebaceous and sweat glands, receptors, nerves and vessels are shown in detail. Mounted on baseboard.

44x24x23 cm; 3.6 kg

L/E/D/S/F/P/J [www.](#)

9982-1000291

6 Different Stages of Skin Cancer Model, enlarged 8 times

- Healthy
- Malignant cells are found at the surface, within the epidermis
- Malignant cells fill the epidermis, a few invade the papillary layer
- Malignant cells fill the papillary layer
- Malignant cells invade the reticular layer
- Malignant cells have reached the subcutaneous faty tissue, satellite cells approach a vein

In the top view, the individual stages of externally visible skin changes are shown, allowing for an assessment according to the "ABCDE" criteria. The sides of the model show the various levels of invasion into the skin layers according to Clark (I-V) and the tumor thickness according to Breslow (in mm). 5 original colour illustrations on the base show various types of malignant melanomas. Mounted on a base.

14x10x11.5 cm; 0.2 kg

L/E/D/S/F/P/J [www.](#)

9982-1000293



9982-1000293



9982-1000254

Nose with Paranasal Sinuses, 5-part

This model illustrates the structure of the nose with the paranasal sinuses in the upper right half of a face in 1.5 times enlargement. The following structures can be seen from the outside, differentiated by colour (also visible through the removable transparent skin):

- The outer nasal cartilages
 - The nasal, maxillary, frontal and sphenoidal sinuses
 - The opened maxillary sinus when the zygomatic arch is removed
- The following structures are shown in a median section:
- The nasal cavity, lined with mucosa, with the nasal conchae (removable)
 - The arteries of the mucous membrane
 - The olfactory nerves
 - The innervation of the lateral wall of the nasal cavity, the nasal conchae and the roof of mouth (palate)

L/D/E/F/S/P/I/J [www.](#)

9982-1000254



Larynx, 2 times full size, 7-part

This medially sectioned model shows:

- Larynx
- Hyoid bone
- Windpipe
- Ligaments
- Muscles
- Vessels
- Nerves
- Thyroid gland

Thyroid cartilage, 2 muscles and 2 thyroid gland halves are removable. On stand.

12x12x23 cm; 0.8 kg

L/E/D/S/F/P/I/J [www.](#)

9982-1000272



9982-1000272

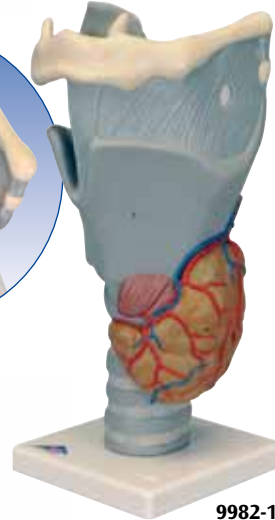

9982-1000271

Functional Larynx, 2.5 times full size

The epiglottis, vocal cords and arytenoid cartilage are movable. Additionally representing the following structures:

- Hyoid bone
- Cricoid cartilage
- Thyroid cartilage
- Thyroid
- Parathyroid glands

On stand.

14x14x28 cm; 0.8 kg

L/E/D/S/F/P/I/J [www.](#)

9982-1000271

Larynx, 2-part

This model shows most of the same features as 9982-1000272, but it is only divisible into two halves.

On stand.

9x9x14 cm; 0.15 kg

L/E/D/S/F/P/I/J [www.](#)

9982-1000273



9982-1000273

Larynx with Bronchial Tree and Transparent Lungs

This unique model was created on the basis of computer tomography data of a human (male, approx. 40 years). What is special about this procedure is that the natural spatial 3D relationships and the reciprocal location of the segmental bronchi can be preserved and depicted in a realistic way. The larynx with hyoid bone and epiglottis and the trachea with primary and lobar bronchi are shown in one colour. The larynx is detachable at the level of the second tracheal cartilage and divisible in the median plane.

The epiglottis is mounted flexibly. The various segmental bronchi are made of elastic material and detailed in various transparent colours so that they are easier to distinguish visually. The transparent lungs are detachable.

19x18x37 cm; 1.3 kg

E/D/S/F/P/I/J [www.](#)

9982-1000275



9982-1000275

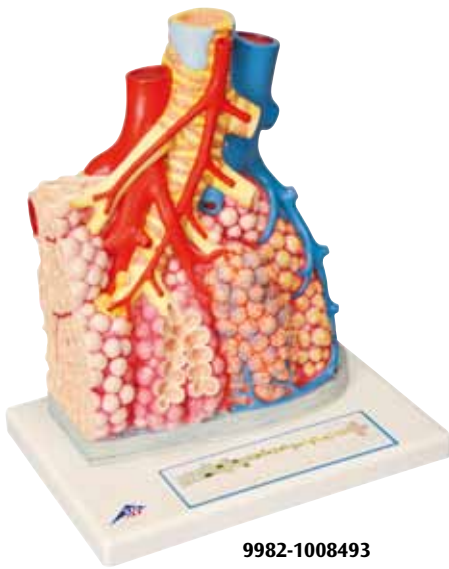

9982-1008493



9982-1001243



9982-1000270



Pulmonary Lobes

The model shows an external pulmonary lobe with a magnification of 130x. The following are represented:

- Segmental bronchus and its terminal branches (bronchioles)
- Alveolus opened on the right side
- Pulmonary vessels and their capillary networks
- Branch of a bronchial artery
- Pulmonary pleura
- Connective tissue septum on the left side
- Single opened alveolus with surrounding capillary network with a magnification of approx. 1000x on the rear side

A graphic representation on the stand of the model shows the structure of the air routes in the lungs up to the alveolus.

26x33x19 cm; 1.4 kg

L/D/E/S/F/P/J/C/R

9982-1008493

Lung Model with Larynx, 5-part

Showing the following features:

- Larynx
- Trachea with bronchial tree
- 2-part heart (removable)
- Vena cava
- Aorta
- Pulmonary artery
- Oesophagus
- 2-part lung (front halves removable)

Delivered on baseboard.

12x28x37 cm; 1.25 kg

L/D/E/F/S

9982-1001243

Lung Model with Larynx, 7-part

This first class model contains the following removable parts:

- 2-part larynx
- Trachea with bronchial tree
- 2-part heart
- Subclavian artery and vein
- Vena cava
- Aorta
- Pulmonary artery
- Oesophagus
- 2-part lung (front halves removable)
- Diaphragm

On baseboard.

31x41x12 cm; 2.2 kg

L/D/E/F

9982-1000270



9982-1010007

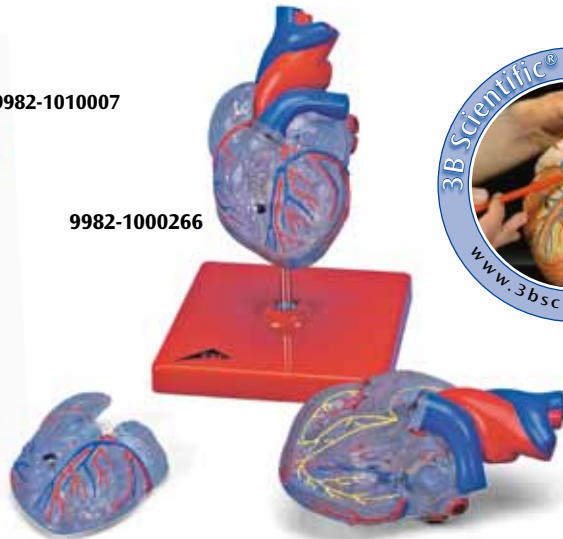

9982-1000266



9982-1000264

Heart Model

The 5-part heart model is a didactically prepared original reproduction of a real human specimen.

- The parts of the model are fixed together with magnetic connections
- They can be taken apart very easily
- A true to original representation of all anatomical structures (e.g. papillary muscles and cardiac valves) in the atria and ventricles.
- Colour scheme and disassembly of the heart model in a didactical manner. The chambers of the heart and vessels (including coronary vessels) in which oxygen rich blood is transported have been displayed in red. Heart chambers and vessels which contain blood low in oxygen have been reproduced in blue.

13x19 cm; 0.6 kg

L/E/D/S/F/P/I/J/C/R

9982-1010007

Classic Heart with Conducting System, 2-part

Same features as 9982-1000264, however, this transparent model also displays the complete conducting system, which is represented in colour. Delivered on removable stand.

19x12x12 cm; 0.2 kg

9982-1000266

Classic Heart, 2-part

Highly detailed 2-part heart at a price you will love. The front heart wall is detachable to reveal the chambers and valves inside. Just slightly smaller than life size with exquisite detail throughout.

On stand.

19x12x12 cm; 0.3 kg

L/E/D/S/F/P/J www.

9982-1000264

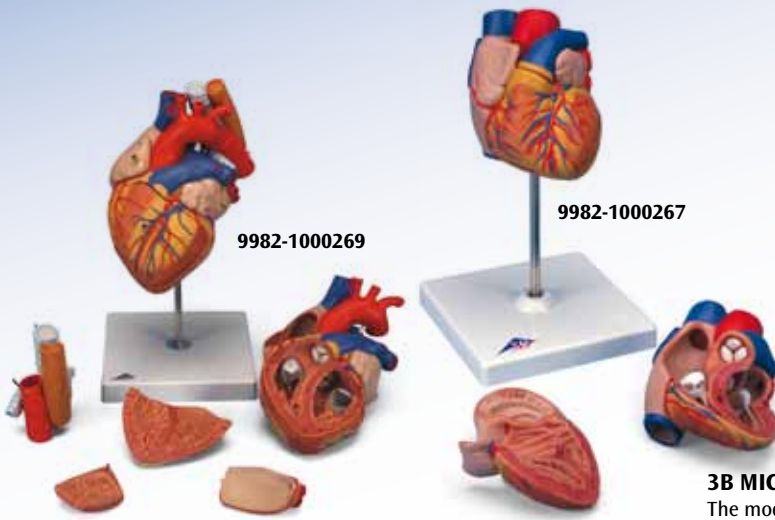

9982-1000269

9982-1000267

Heart with Oesophagus and Trachea, 2 times life size, 5-part

Same features as 9982-1000268. Additionally depicts the upper section of the oesophagus, the upper bronchi and the ascending aorta. The front heart wall and the atrium walls can be removed. Delivered on removable stand.

32x18x18 cm

L/D/E/F

9982-1000269

Heart Model, 2-part

This model shows the anatomy of the human heart with ventricles, atriums, valves, veins, and the aorta in great detail. The front heart wall is removable to view the chambers and internal structures. Delivered on removable stand.

22x12x12 cm; 0.35 kg

L/E/D/S/F/P/J www.

9982-1000267



9982-1000279

3B MICROanatomy™ Artery and Vein

The model shows a medium sized muscular artery with two adjacent veins from the antebrachial area with adjoining fat tissue and muscle enlarged 14 times. The model illustrates the reciprocal anatomical relationship of artery and vein and the basic functional techniques of the venous valves (“valve function” and “muscle pump”). The left vein and the middle artery are fenestrated in the upper anterior segment, revealing the various layers of the wall structure in a cross and longitudinal section and in top view. The right vein is opened throughout in the anterior segment, revealing the orifice of a feeder vein and two venous valves, i.e. “flap valves” formed by a duplication of the tunica intima. On the rear of the model, the relief of two veins is shown to illustrate the functional aspect of the venous valves. Supplied on base.

26x19x18.5 cm; 0.9 kg

L/D/E/S/F/P/I/J

9982-1000279



9982-1005045



9982-1000277

Functional Heart and Circulatory System

This amazing working model will bring your lecture to life! A complete schematic model of the human circulatory system with “blood” (coloured water) that flows through transparent veins, arteries, capillaries and heart chambers. This model’s special design portrays venous blood, a deep red-purple and arterial blood, a bright red to give visual reinforcement to the oxygenation and deoxygenation of haemoglobin as it travels the body’s vascular network. Mounted on a baseboard with support legs and supplied with teacher’s guide, red dye and syringe for refilling the system.

36x16x38 cm; 1.5 kg

E

9982-1005045

Hypertension Model, 7-part

This model shows the harmful effects of hypertension on the most susceptible organs. It consists of scaled down depictions of: Brain, Eye, 2-part heart, 2-part kidney, an enlarged artery.

34.5x11.5x11.5 cm; 0.9 kg

E www.

9982-1000277



9982-1013002

Venous Valves in Operation According to Bischof

Venous valves ensure that the blood in the veins flows back to the heart against gravity despite the low pressure. If the blood flows “backwards”, the valves close the veins like check valves. This mechanism can be demonstrated wonderfully using our model made of transparent acrylic; the “venous valves” open just like the vascular system of vertebrates. Only the blood flow is not shown. Instead, the model demonstrates this with a stream of air. You will be able to show your pupils the blood flow with opened valves, and the mounting backlog when the valves are closed.

31x3x3 cm, 0.07 kg

9982-1013002

Arteriosclerosis Model, with Cross Section of Artery, 2-part

With the help of this model doctors can explain changes in the blood vessels due to arteriosclerosis. A horizontally dissected artery fork is depicted with arteriosclerotic changes in four different stages, from slightly sedimented to a completely clogged vessel. On stand.

15 cm; 0.2 kg

9982-1000278



9982-1000278

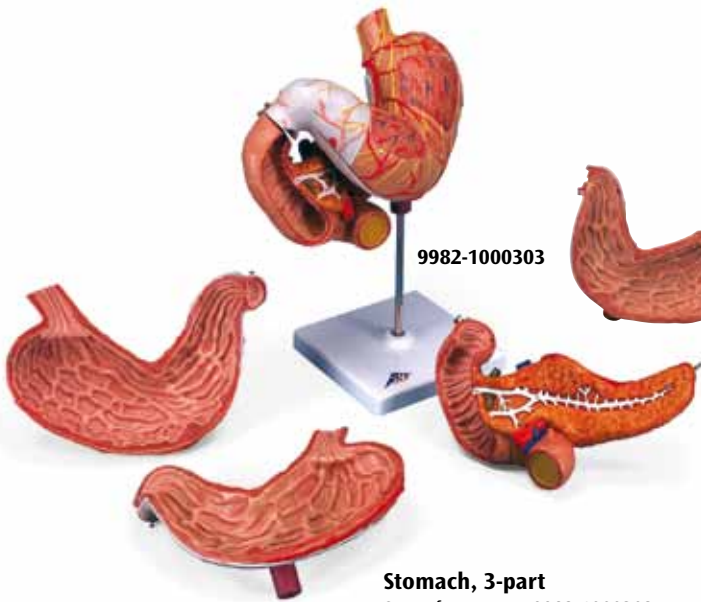

9982-1000303

9982-1000302

Stomach, 3-part

Same features as 9982-1000302, additionally displaying the removable duodenum and pancreas. Supplied on stand. 25x22x12 cm; 0.8 kg
L/D/E/F
9982-1000303

Stomach, 2-part

The model shows the different and individual layers of the stomach wall. The front half of the stomach is removable. Depicted are:
 • The lower oesophagus
 • Vessels
 • Nerves
 Supplied on stand. 25x22x12 cm; 0.6 kg
L/D/E/F
9982-1000302



9982-1000313

Liver with Gall Bladder

• 4 lobes with gall bladder
 • Extrahepatic ducts
 • Hilus vessels
 On removable stand. 18x18x12 cm; 0.5 kg
L/D/E/F
9982-1000313



9982-1000307

Digestive System, 3-part

Life size model which accurately represents the entire digestive system in relief format. Features:
 • Nose
 • Mouth cavity and Pharynx
 • Oesophagus
 • GI tract
 • Liver with gall bladder
 • Pancreas
 • Spleen
 The duodenum, caecum and rectum are opened. The transverse colon and front stomach wall are removable. Mounted on baseboard. 81x33x10 cm; 4.4 kg
L/D/E/S/F/P/I/J www.
9982-1000307

Liver with Gall Bladder, Pancreas and Duodenum

This excellent relief model shows the liver with:
 • Ducts
 • Gall bladder
 • Pancreas
 • Duodenum
 • Vessels
 • Extra hepatic ducts with gall bladder
 • Main pancreatic duct and their orifices
 On baseboard. 4x20x18 cm; 0.8 kg
L/E/D/S/F/P/I/J www.
9982-1008550



9982-1008550

3B MICROanatomy™ Liver

This 2-part model shows a highly magnified diagrammatic view of a section of the liver. The left part of the model shows a section of the liver that comprises several lobules. The right part of the model is a highly magnified view of the sectioned lobule on the left. 15x26x18.5 cm; 0.7 kg
L/E/D/S/F/P/I/J www.
9982-1000312

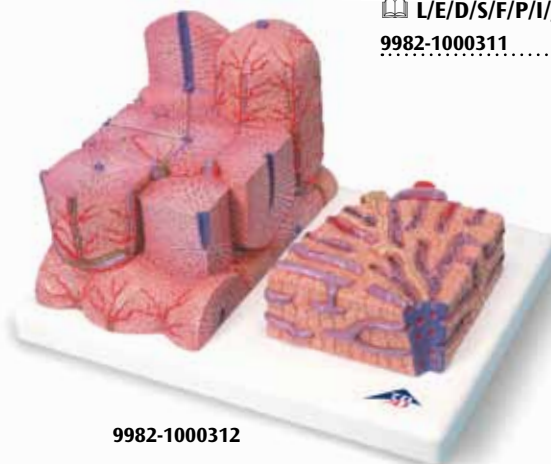

9982-1000312

3B MICROanatomy™ Digestive System

The model illustrates the structure of the fine tissues of four characteristic sections of the digestive system: oesophagus, stomach, small intestine, large intestine. The front of the model, from top to bottom, shows a magnified view in histological section of the individual sections of the digestive system and their fine tissue structures. On the back of the model, highly magnified views of didactically interesting areas of each of the digestive system sections shown on the front are emphasized. 29.5x26x18.5 cm; 1.5 kg
L/E/D/S/F/P/I/J www.
9982-1000311



9982-1000311



9982-1000308

Kidneys with Vessels, 2-part
 This model shows the kidneys with suprarenal glands, the outgoing ureters, the renal vessels and the large vessels situated close to the kidneys in natural size. The front half of the right kidney can be removed to reveal the renal pelvis, the renal calices, the renal cortex and the renal medulla.
 On stand.
 21x18x28 cm; 1.0 kg
 L/E/D/F
 9982-1000308

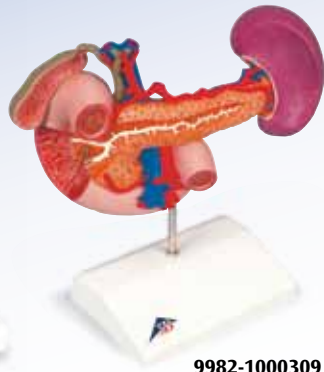

9982-1000309

Rear Organs of the Upper Abdomen
 The model shows the duodenum (partially opened), gall bladder and bile ducts (opened), the pancreas (revealing large ducts), the spleen and the surrounding vessels in natural size. On stand.
 23x12x20 cm; 0.55 kg
 9982-1000309



9982-1000310

Kidneys with Rear Organs of the Upper Abdomen, 3-part
 This model combines models 9982-1000308 and 9982-1000309. The upper abdominal organs are attached in their natural positions and may be separated from the kidneys. On stand.
 24x18x29 cm; 1.4 kg
 9982-1000310



9982-1000300

Kidney with Adrenal Gland, 2-part
 This model shows:
 • Kidney with adrenal gland
 • Renal and adrenal vessels
 • Upper portion of ureter
 The front half of the kidney is removable to enable demonstration of cortex medulla and vessels as well as renal pelvis. On stand.
 20x12x12 cm; 0.9 kg
 L/D/E/F/S/P/I/J/R/C www.
 9982-1000300

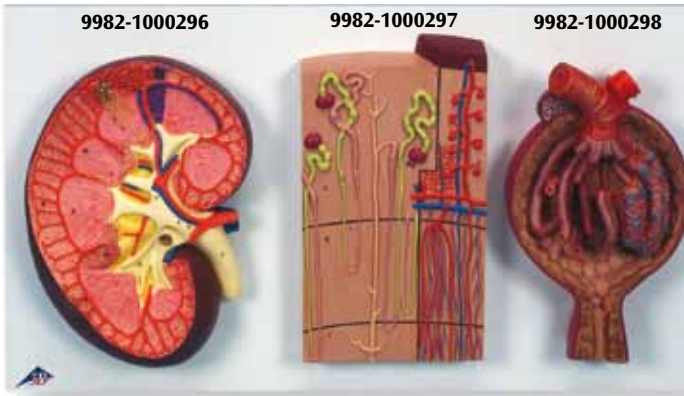

9982-1000299

Kidney Section, Nephrons, Blood Vessels and Renal Corpuscle
 A complete series of 3 models (9982-1000296, 9982-1000297 and 9982-1000298) for studying the kidney and its different structures in great detail. Delivered on baseboard.
 29x52x9 cm; 2.8 kg
 L/E/D/S/F/P/I/J www.
 9982-1000299

Kidney Section, 3 times full size
 Longitudinal section of the right kidney. On baseboard.
 33x20x10 cm; 1.0 kg
 L/E/D/S/F/P/I/J www.
 9982-1000296

Nephrons and Blood Vessels, 120 times full size
 On baseboard.
 26x19x5 cm; 0.7 kg
 L/E/D/S/F/P/I/J www.
 9982-1000297

Malpighian Corpuscle of Kidney, 700 times full size
 On baseboard.
 26x19x8 cm; 0.7 kg
 L/E/D/S/F/P/I/J www.
 9982-1000298



9982-1000317

Dual Sex Urinary System, 6-part
 • Structures of retroperitoneal cavity
 • Large and small pelvis with bones and muscles
 • Inferior vena cava
 • Aorta with its branches including iliacal vessels
 • Upper urinary tract
 • Rectum
 • Kidney with adrenal gland.
 One front half of a kidney is removable. With easy to change male insert (bladder and prostate, front and rear half) and female insert (bladder, womb and ovaries, 2 lateral halves). Parts are numbered.
 On baseboard.
 41x31x15 cm; 2.3 kg
 L/E/D/S/F/P/I/J/R/C www.
 9982-1000317



9982-1008551

Urinary System, male, 3/4 times full size
 • Inferior vena cava
 • Renal veins
 • Aorta with its branches
 • Iliacal vessels
 • Ureter
 • Urinary bladder
 • Prostate
 • Adrenal gland
 • Rectum
 • Musculature
 The right kidney is opened.
 10x18x26 cm; 1.0 kg
 L/D/E/F/S
 9982-1000317



9982-1000331

3B Scientific® Pregnancy Series, 5 Models

The series consists of 9982-1000322, 9982-1000323, 9982-1000324, 9982-1000326 and 9982-1000329 with embryo or foetus to show the most important stages of development of. All models are mounted together on a base.

13x41x31 cm; 2.1 kg

L/D/E/F/P/S/J www.3b.com

9982-1000331



9982-1000333

Pregnancy Pelvis, 3-part

Representation of a median section through the female pelvis during the 40th week of pregnancy with a removable foetus. A model to study the normal position of child before birth. An uterus with embryo in 3rd month of pregnancy is mounted on base for added detail.

38x25x40 cm; 3.8 kg

L/D/E/F

9982-1000333

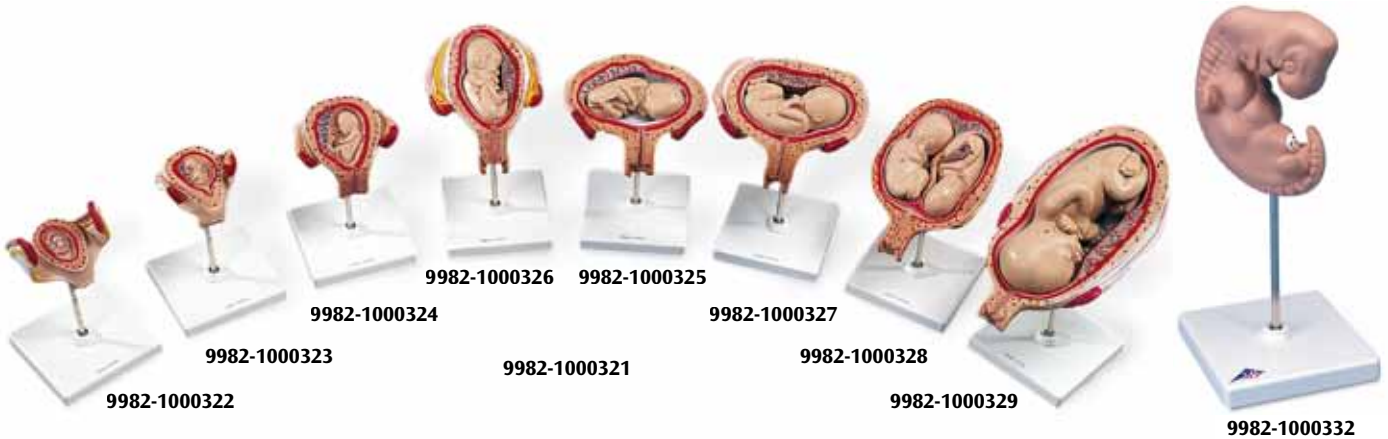

9982-1000322

9982-1000323

9982-1000324

9982-1000326

9982-1000321

9982-1000325

9982-1000327

9982-1000328

9982-1000329

9982-1000332

3B Scientific® Pregnancy Series

Our most popular series includes 8 models to show all the stages of development.

12x12x19 cm; 3.2 kg

L/E/D/S/F/P/I/J/R/C www.3b.com

9982-1000321

1st Month Embryo

0.2 kg

9982-1000322

2nd Month Embryo

0.3 kg

9982-1000323

3rd Month Embryo

0.3 kg

9982-1000324

4th Month Foetus, transverse lie

0.4 kg

9982-1000325

5th Month Foetus, breech position

0.4 kg

9982-1000326

5th Month Foetus, transverse lie

0.4 kg

9982-1000327

5th Month Twin Foetuses, normal position

0.6 kg

9982-1000328

7th Month Foetus

15x32x27 cm; 0.6 kg

9982-1000329

Embryo, 25 times life size

Showing embryo approx. 4 weeks old.

12x12x23 cm; 0.3 kg

L/E/D/S/F/P/I/J/R/C www.3b.com

9982-1000332

Deluxe 3B Scientific® Pregnancy Series, 9 Models

All models from our 9982-1000327 plus the Embryo 9982-1000332.

12x12x19 cm – 15x32x27 cm

L/E/D/S/F/P/I/J/R/C www.3b.com

9982-1000330



9982-1001257

Embryonic Development in 12 stages

The model represents the development of the human germ cells from fertilisation until the end of the 2nd month of pregnancy in 12 stages. Each stage can be removed from the common stand as an individual part and can be removed used for teaching and tests for the embryological specialist field.

- Ovum at time of fertilisation (conception) with male gamete (sperm)
- Zygote at 2-cell stage, approx. 30 hours after fertilisation
- Zygote at 4-cell stage, after around 40-50 hours
- Zygote at 8-cell stage, after around 55 hours
- Morula
- Blastocyst after around 4, 5 and 8-9 days
- Germ cells at approx. 11th day and approx. 20th day
- Embryo at around the end of the 1st and 2nd month of pregnancy

65x6x34.5 cm; 1.55 kg

L/E/D/S/F/P/I/J/R/C

9982-1001257

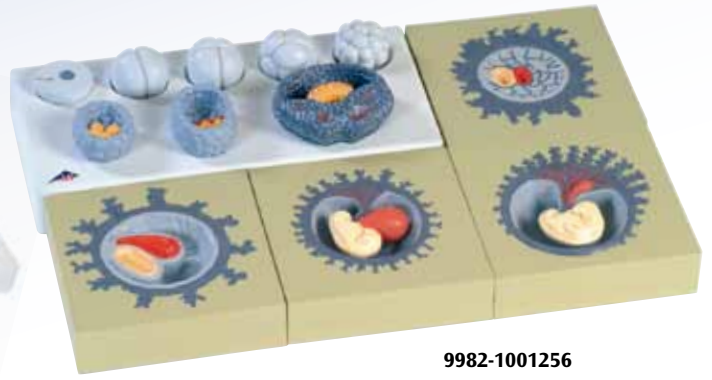

9982-1001256

Embryonic Development, 12 stages

- Ovule shortly after fertilization
- Two cell stage
- Four cell stage
- Seven cell stage
- Morula stage
- Blastocyst with trophoblast and embryoblast
- Blastocyst with early formation of embryo process
- Blastocyst with start of implantation
- Embryo (approx. 12th day)
- Embryo (approx. 20th day)
- Embryo (approx. 28th day)
- Embryo (approx. 2nd month)

The first 8 models are enlarged approx. 4,000 times, the other 4 models are enlarged approx. 4-5 times. The first 8 stages can be removed from the baseboard for closer study. Delivered in storage carton.

12x59x41 cm; 3.35 kg

L/D/E/F/S

9982-1001256



9982-1000320

Stages of Fertilisation and Development of the Embryo, 2 times magnified

The model illustrates schematically how the ovum matures, how ovulation and fertilisation occur and how the fertilised ovum develops to the stage where it embeds itself in the uterine wall to begin the growth into an embryo. The various stages are shown in larger-than-life model form in ovary, fallopian tube. An even more enlarged illustration of each is also printed on the base.

Supplied on a base.

35x21x20 cm, 1.2 kg

L/D/E/S/P/I/J www.

9982-1000320



9982-1001259

Labour Stages Model

Same as 9982-1001258, but reduced in size to 50%. Supplied on baseboard.

40x31x13 cm; 1.4 kg

9982-1001259



9982-1002501

Embryo Development, 12 stages

With the common frog as an example (Rana temporaria), the different stages of the embryo development are shown 30 times magnified.

9982-1002501

New Anthropological Skulls from 3B Scientific

These models are finest castings produced from scientifically made copies of specimens featured in the collection at the Institute of Anthropology and Human Genetics for Biologists at the Johann-Wolfgang-Goethe University, Frankfurt/Main, Germany. This means that all the details are reproduced absolutely accurately. The unique replicas are enhanced by being displayed on a pedestal that contains a relief map* of the geographical area where the specimen was found.

Anthropological Skull – Sinanthropus

This skull is an accurate casting of a Sinanthropus skull reconstructed by Weinert and modelled from drawings by Black and Weidenreich after all the original bone specimens had been lost. Sinanthropus belongs to the genus *Homo erectus pekinensis* (*Sinanthropus pekinensis*) and can be seen as a typical example of early man. Discovered at: Zhoukoudian 40 km south west of Peking; Discovery: 1929-1936; Age: 400,000 years. 21x14.5x21.5 cm; 0.9 kg

L/D/E/F/P/S/I/J

9982-1001293



Anthropological Skull – La Chapelle-aux-Saints

Cast from a reconstruction of the La Chapelle-aux-Saints skull, the model skull is an accurate copy of one belonging to a 50-55 year old male Neanderthal from ancient Europe of the species *Homo (sapiens) neanderthalensis*. Early man. Discovered at: southern France Discovery: 1908; Age: Approximately 35,000 to 45,000 years. 22x16x22.5 cm; 0.9 kg

L/D/E/F/P/S/I/J

9982-1001294



Anthropological Skull – Crô-Magnon

This wonderful casting is a reconstruction of an early hominid called Crô-Magnon man. The age of the original is dated to be 20,000 to 30,000 years old. The skull itself belonged to an early modern man of the species *Homo sapiens sapiens* from the ice age of the neo-Palaeolithic era. Early man (neo-Palaeolithic). Discovered at: a cave in Vézère/ southern France; Discovery: 1868; Age: 20,000 to 30,000 years. 21.5x15x24.5 cm; 0.9 kg

L/D/E/F/P/S/I/J

9982-1001295



Anthropological Skull – Steinheim

This Steinheim model is a detailed casting from Berkheimer's reconstruction (1936, skull with no jawbone). The original of this skull from a forerunner of Neanderthal man was a *Homo (sapiens) steinheimensis* aged between about 25 and 35 and was discovered in a gravel in Steinheim, southern Germany, in 1933. Forerunner of a Neanderthal man or an ancient *Homo sapiens*. Discovered at: a gravel pit near Steinheim an der Mur, Germany; Discovery: 1933; Age: approximately 250,000 years. 19x12.5x21.5 cm; 0.7 kg

L/D/E/F/P/S/I/J

9982-1001296



Anthropological Skull – Broken Hill or Kabwe

An accurate casting of a skull reconstructed from an original that was discovered in an iron ore working at Broken Hill, in northwest Rhodesia (modern-day Kabwe in Zambia). It is an example of the early man, *Homo sapiens rhodesiensis* or a *Homo erectus rhodesiensis*, and indications exist to point to both these classifications. For this reason, there is also a wide range in the estimates of the specimen's age based on differing scientific assumptions. An early example of an ancient *Homo sapiens* (as classified by Henke and Rothe 1994) or a *Homo erectus rhodesiensis*. Discovered at: a cave in an ore working at Broken Hill, modern-day Kabwe in Zambia. Discovery: 1921. Age: probably 150,000 to 300,000 years old. Previous estimates were of 40,000 to 60,000 years. 21x15.5x23.5 cm; 0.8 kg

L/D/E/F/P/S/I/J

9982-1001297



Anthropological Skull – KNM-ER 406, Omo L. 7a-125

This model is a high-quality casting of a reconstruction of the Kalvarium skull (KNM-ER 406) with a partial mandible (Omo L. 7a-125). The Kalvarium skull is approx. 1.7 million years old and was discovered at Lake Rudolph (now called Lake Turkana) in 1970. The partial mandible comes from a different dig but is clearly from the same species. The classification of the species has not yet been indisputably clarified. Discussions continue as to whether the specimen is an *Australopithecus boisei* or a *Paranthropus boisei*. Example of a pre-human hominid. Discovered at: Lake Turkana, formerly Lake Rudolph; Discovery: 1970; Age: about 1.7 million years. 18x18x22.5 cm; 0.8 kg

L/D/E/F/P/S/I/J

9982-1001298



*Example detail of base

Plastinated Slices

Cross sections of real specimens provide insight into the perfect interplay between the systems and structures of the human body. Embracing everything from an aesthetic overview to the finest detail, every single plastinate reveals an unaltered and credible basic understanding of life science and anatomical contexts.

The “Tissue Tracing Technique” allows us to view complex anatomical structures and provides a completely new understanding of fundamental functional interconnections. High-grade plastic materials, each with a defined refraction index adapted to the respective tissue, are applied to penetrate the tissue, making it transparent.

To ensure practically unlimited durability, the plastinated slices are cast between acrylic protection layers. Each acrylic layer is 10 mm thick and protects the plastinate against UV rays, scratches and other damage.

Customized items are available upon request.

9982-1005381



9982-1005383



9982-1005384



9982-1005382



9982-1005385

**Plastinated Slices –
Horse's Hoof**

9982-1005381

**Plastinated Slices –
Pig's Foot**

9982-1005382

**Plastinated Slices –
Chick**

9982-1005383

**Plastinated Slices –
Fish**

9982-1005384

**Plastinated Slices –
Rat**

9982-1005385



9982-1005973

Monarch – *Danaus genutia* (Cramer)

Monarchs are the only butterflies that migrate. They fly south each autumn and return north in spring when the weather is warmer. This is why they are also called “wanderers”. A monarch butterfly has large, colourful wings and small front legs. Its wingspan is about 10 cm across. Monarchs are brown or orange-brown, with black and white markings. These Real Monarch Butterfly specimens (10 cm) are encased in a clear circular acrylic. Supplied with storage box.

100x25 mm; 150 g

9982-1005973



9982-1000525

Castor Bean Tick (*Ixodes ricinus*)

Accurately detailed replica of the castor bean tick; scale: 25:1. 12x12x2 cm; 0.035 kg

9982-1000525

Case with 27 Different Embedded Specimens

This high quality set is an excellent substitute for original living specimens. The natural appearance, shimmering colours and lifelike 3D view makes working with these unique and inexpensive specimens a fascinating experience for your students. These fine specimens are not generally hunted or caught by us, but originate from legal breeding or pest control sources. Each specimen is prepared with great care before encasement in a high quality transparent acrylic block. Teaching can hardly get more fascinating and true-to-life!

Common Name

1. Chafer Beetle
 2. Lady bug
 3. Mole Cricket
 4. Praying Mantis
 5. Paper Wasp
 6. Honey bee
 7. Ant
 8. Dung beetle
 9. Rhinoceros beetles
 10. Monarch
 11. Long-horned Beetle
 12. Cicada
 13. Shield bug
 14. Wespspin Spider
 15. Dragonfly
 16. Cricket
 17. Cockroach
 18. Scorpion
 19. Centipede
 20. Walking stick
 21. Onion Fly
 22. Chinese shrimp
 23. Silkworm
 24. Crab
 25. Star fish
 26. Grasshopper
 27. Stag beetle
- 42x33x8cm; 5 kg

Scientific Name

- Anomala Cuprea Hope
 Synonycha grandis (Thunberg)
 Gryllotalpa orientalis Burmeister
 Hierodula petellifera (Serville)
 Polistes olivaceus (De Geer)
 Apis cerana
 Pheidologeton latinodus Zhou et Zeng
 Catharsius molossus (Linnaeus)
 Xylotrupes Gideon (Linnaeus)
 Danaus genutia (Cramer)
 Anoplophora chinensis (Forster)
 Cryptotympana atrata (Fabricius)
 Eusthennes cupreus (Westwood)
 Argiope bruennichii (Scopoli)
 Brachythemis contaminata
 Teleogryllus emma (Ohmachi et Mastsumura)
 Periplaneta australasiae (Fabricius)
 Urodacus novae-hollandiae
 Scolopendra
 Diaperomera femorata
 Delia antiqua Meigen
 Penaeus chinensis (Osbeck)
 Bombyx mandarina moore
 Nectocarcinus intigrifrons
 Asterias amurensis Lutken
 Catantops splendens
 Odontolabis cuvera fallaciosa

9982-1005970



9982-1005970

The Life of the Honeybee – Apis cerana

These vividly illustrative embedded specimens give your students an excellent insight into the world of the honeybee. Included are high quality specimens of 1. Egg, 2. Larva, 3. Pupa, 4 Adult (Worker), 5 Adult (Drone), 6. Adult (Queen), 7. The Base of Nest, 8. Worker Comb, 9. Queen Comb, 10. Bee Pollen, 11. Honey, 12. Wax.

165x80x25 mm; 150 g

9982-1005971



9982-1005971

Fish Skeleton – African Catfish (Clarias gariepinus)

On wooden base. 70x30x30 cm; 6 kg

9982-1002564

9982-1002564

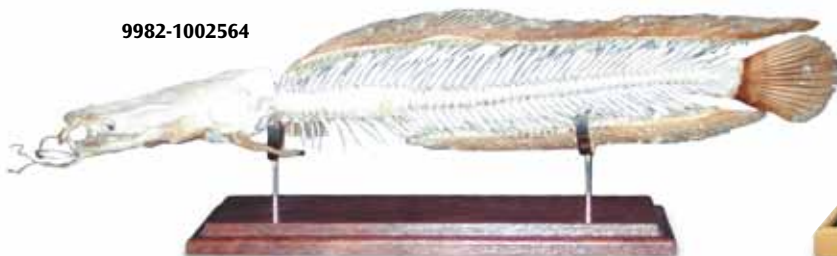

Fish Skeleton – Carp (Cyprinus carpio)

In showcase. 70x30x54 cm; 4 kg

9982-1002533

9982-1002533

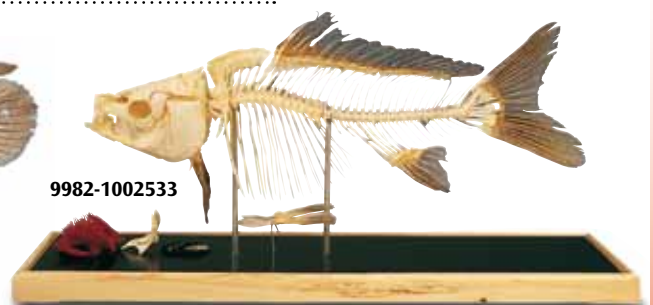

The following 3B Scientific® Products depict common amphibians and reptiles in their natural size and are great supporting aids for an exciting Biology lesson. Each is modelled and detailed as if moving through their natural habitat. The smallest details of marking and colouration allows students to recognize the characteristics of the different species on these amazingly realistic works of art. Unless otherwise stated, all models are mounted on a nature like base.

*hand-painted
true to nature!*

Vertebrates: Amphibians & Reptiles



Tree Frog, male
(*Hyla arborea*)
9982-1001268



Tree Frog, female
(*Hyla arborea*)
9982-1001269



Common Spadefoot Toad, male
(*Pelobates fuscus*)
9982-1001279



Common Spadefoot Toad, female
(*Pelobates fuscus*)
9982-1001280



Moor Frog
(*Rana arvalis*)
9982-1001272



Fire-Bellied Toad
(*Bombina bombina*)
9982-1001284



Common Toad, male
(*Bufo bufo*)
9982-1001277



Common Toad, female
(*Bufo bufo*)
9982-1001278



Common Frog, male
(*Rana temporaria*)
9982-1001270



Common Frog, female
(*Rana temporaria*)
9982-1001271



Green Toad, male
(*Bufo viridis*)
9982-1001281



Green Toad, female
(*Bufo viridis*)
9982-1001282



Edible Frog, male
(*Rana esculenta*)
9982-1001273



Edible Frog, female
(*Rana esculenta*)
9982-1001274



Natterjack Toad
(*Bufo calamita*)
9982-1001283



Agile Frog
(*Rana dalmatina*)
9982-1001276

Zoological Models



Midwife Toad
(*Alytes obstetricans*)
9982-1001275



Fire Salamander
(*Salamandra salamandra*)
9982-1001267



Viviparous Lizard
(*Lacerta vivipara*)
9982-1001286



Sun Lizard, male
(*Lacerta agilis*)
9982-1001287



Sun Lizard, female
(*Lacerta agilis*)
9982-1001288



Slow Worm (*Anguis fragilis*)
9982-1001285



Smooth Snake
(*Coronella austriaca*)
9982-1001292

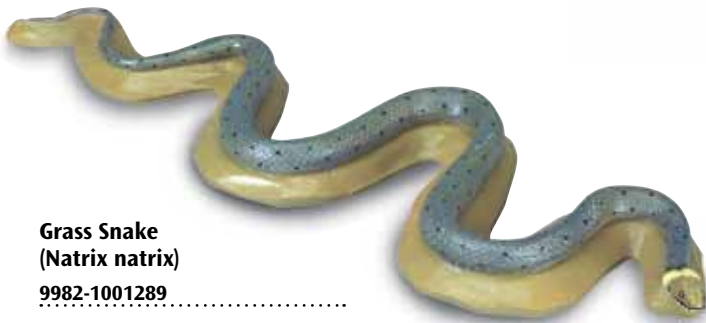

Grass Snake
(*Natrix natrix*)
9982-1001289



Dice Snake
(*Natrix tessellata*)
9982-1001291



Common Viper or Adder
(*Vipera berus*)
9982-1001290

Unless otherwise stated all animal skeletons are constructed from natural bones. The individual bones of the animal skeletons are sturdily mounted and durable. Some animal skeletons have flexibly mounted joints and thus all natural postures can be seen and demonstrated.

All animal skeletons have been obtained legally and may occasionally require longer delivery times due to supply and demand.

Chicken Skeleton (Gallus gallus)

In showcase.

9982-1002534



9982-1002534

Duck Skeleton (Anas platyrhynchos)

In showcase.

9982-1002558



9982-1002558

9982-1002566



Dove Skeleton and Stuffed Dove (Columba palumbus)

In showcase.

9982-1002566

9982-1002535



Dove Skeleton (Columba palumbus)

In showcase.

32,5x31,5x32,5 cm; 2 kg

9982-1002535

9982-1002562



Pheasant Skeleton (Phasianus colchicus)

Flexibly mounted, in showcase.

9982-1002562

Wing and Feathers of a Dove (Columba palumbus)

In showcase, labelling in English.

9982-1002557



9982-1002557

9982-1002563

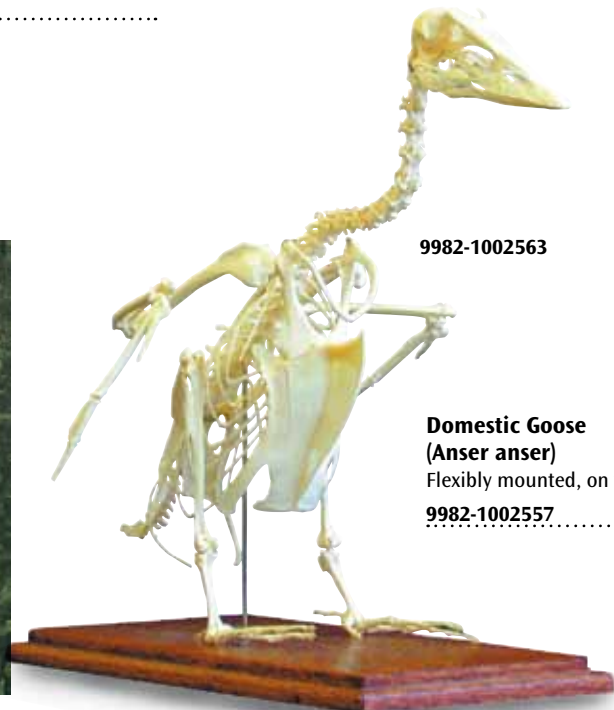

Domestic Goose (Anser anser)

Flexibly mounted, on wooden base.

9982-1002557



9982-1002565

Mouse Skeleton and Stuffed Mouse

In showcase.

9982-1002565

Rat Skull (Rattus rattus)

9982-1002552

Hare Skull (Lepus europaeus)

Flexibly mounted.

9982-1002546



9982-1002552



9982-1002546



Rat Skeleton (Rattus rattus)

In showcase.

9982-1002565

9982-1002538



9982-1002536

Hare Skeleton (Lepus europaeus)

In showcase.

9982-1002536

Types of Animal Teeth

This series shows the different types of teeth of cows (ruminant), pigs, dogs, cats (terrestrial carnivores), rabbits, rats (rodents).

- | | |
|----------------------|-----------------------|
| 1. Pig: Incisors | 9. Rat: Molars |
| 2. Pig: Canine teeth | 10. Cat: Incisors |
| 3. Pig: Molars | 11. Dog: Incisors |
| 4. Cow: Incisors | 12. Cat: Canine teeth |
| 5. Cow: Molars | 13. Dog: Canine teeth |
| 6. Hare: Incisors | 14. Cat: Molars |
| 7. Rat: Incisors | 15. Dog: Molars |
| 8. Hare: Molars | |

9982-1002554



9982-1002551

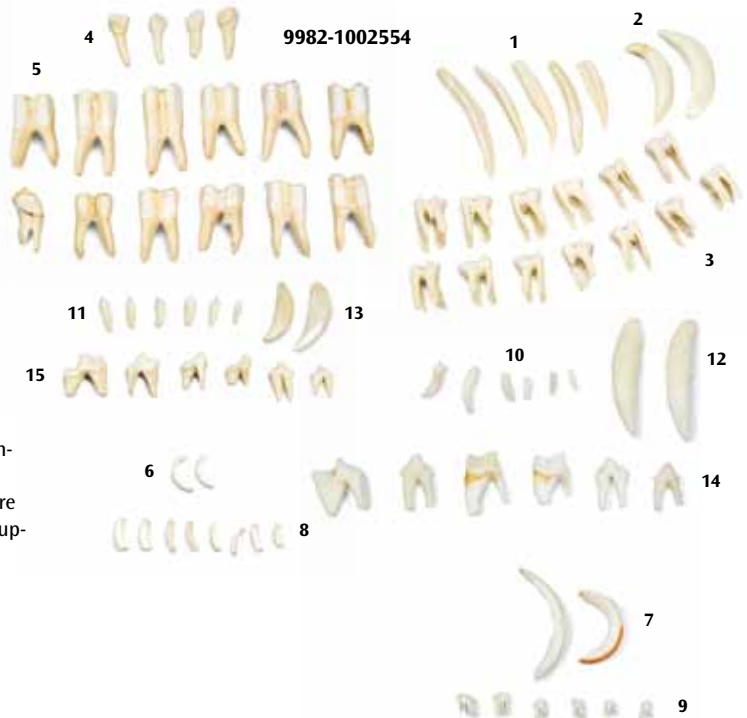

Mammal Feet

This series graphically shows the different types of mammalian feet. Consisting of foot skeletons of: horse or cow, pig and sheep with separately mounted hooves as well as leg skeletons with shoulder blade of: cat, hare and dog. Mounted on a wooden base. Please note that the leg may be supplied without the scapula bone.

72x44x60 cm; 7 kg

9982-1002551



9982-1005104

Dog Skull (Canis domesticus)
Medium sized dog skull, cast from nature, with removable lower jaw. Made of unbreakable plastic.
9982-1005104

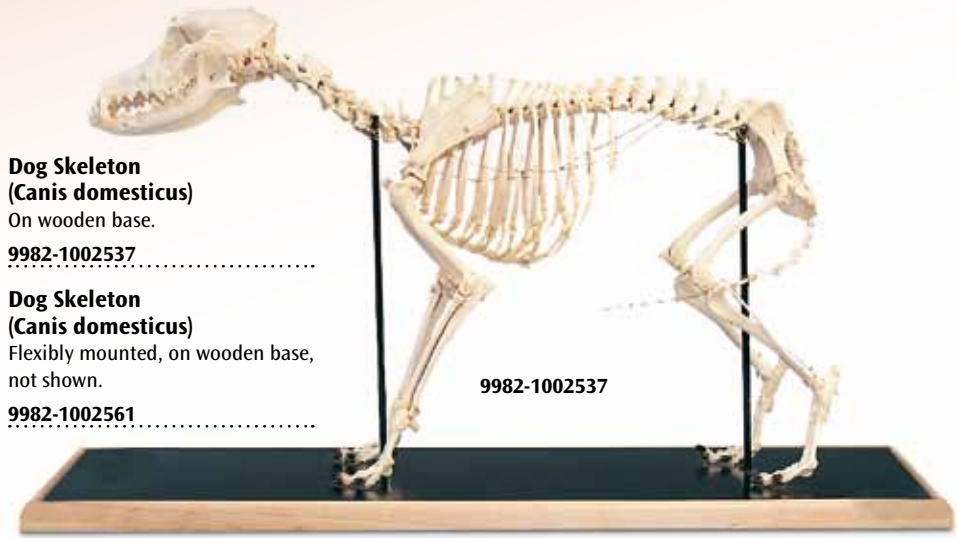

Dog Skeleton (Canis domesticus)
On wooden base.
9982-1002537

Dog Skeleton (Canis domesticus)
Flexibly mounted, on wooden base, not shown.
9982-1002561

9982-1002537



9982-1002553

Dog Leg (Canis domesticus)
Please note that the dog leg may be supplied without the scapula bone.
9982-1002556

Dog Skull (Canis domesticus)
Flexibly mounted.
9982-1002548

Cat Skeleton (Felis catus)
On wooden base.
9982-1002553

Cat Skeleton (Felis catus)
Flexibly mounted, in showcase, not shown.
9982-1002560



9982-1002547

Cat Skull (Felis catus)
Flexibly mounted.
9982-1002547

9982-1002548



9982-1002556



9982-1002550

9982-1002555

Pig Skull (Sus scrofa)
Flexibly mounted.
9982-1002543

Cow Skull (Bos taurus)
Please note that the cow skull may be supplied without the horns.
9982-1002542

Horse Foot (Equus caballus)
9982-1002550

Cow Foot (Bos taurus)
9982-1002555

Pig Foot (Sus scrofa)
Not shown.
9982-1002549

Cow Skeleton (Bos taurus)
On wooden base, not shown.
9982-1002539



9982-1002543

9982-1002542



Horse Skeleton
(*Equus caballus*)

9982-1002541

Horse Skull
(*Equus caballus*)

Delivery time on demand.

9982-1002544



9982-1002544

Sheep Skull (*Ovis aries*)

Fully developed sheep skull, cast from nature, with removable lower jaw. Made of unbreakable plastic.

E

9982-1005105



9982-1005105

Chimpanzee Skull
(*Pantroglydytes*), female

This model was cast from an original from the Collection of the Johann Wolfgang Goethe University of Frankfurt am Main, Institute of Anthropology and Human Genetics for Biologists.

17x11.5x14 cm; 0.5 kg

9982-1001299

Gorilla Skull
(*Gorilla gorilla*), male

Cast from nature, with movable lower jaw.

26x16.5x19.5 cm; 0.8 kg

9982-1001301



9982-1002541



9982-1002545

Sheep Skull (*Ovis aries*)

Flexibly mounted.

9982-1002545

Pig Skeleton (*Sus scrofa*)

On wooden base.

9982-1002540

Orang-Outang Skull
(*Pongopygmaeus*), male

This model was cast from a replica of the original skull from the Senckenberg Research Institute and Natural History Museum in Frankfurt/Main.

22x16x18 cm; 0.6 kg

9982-1001300



9982-1002540



9982-1001300



9982-1001299



9982-1001301

Monocotyledonous Plants

The family of monocotyledonous plants includes grasses, orchids, lily plants and palms. There are more than 66,000 different species worldwide.

Grasses

The narrow, sharp and parallel running leaves are typical of the gramineae genus. The air pollinated and generally androgynous flowers are arranged in heads.



9982-1002511



Wheat (*Triticum aestivum*)

Model of a spicule magnified 15 times, with removable and dissectible single flower.
52 cm; 0.8 kg

9982-1002511

Lily Grasses (Liliaceae)

Lily grasses are characterized by bulbs and their large, funnel shaped flowers.



9982-1002512

Tulip (*Tulipa gesneriana*)

The section of stamen and pistils is removable, 3 times magnification.
51 cm; 0.4 kg

9982-1002512



Dicotyledonous Plants

The family of dicotyledonous plants includes the majority of angiosperms and all woody plants. There are more than 174,000 species world-wide.

Dicotyledonous Flower

The pollination of the angiosperms can be taught using this magnified model of an idealized flower with, torus, ovary, and style.

Removable are:

- 3 petals
- 4 sepals
- 4 filaments
- 2 anthers and the ovary are cut partly to show the inner structures. 6 pollen grains that are mounted on the style can be easily identified.

E

9982-1005541

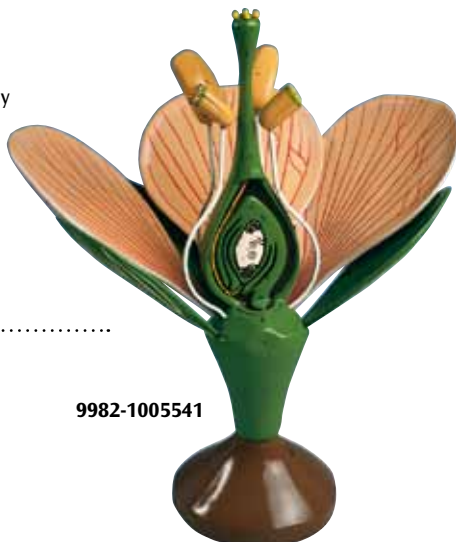

9982-1005541

Composite Flowers (Asteroideae)

Typical of the asteroideae species is the torus mostly featuring many single flowers, which are surrounded by a mutual involucre. Asteroideae are often useful or medicinal plants.

Sunflower (*Helianthus annuus*)

The model shows the inner tubular corolla magnified 10 times and the outer ray flower magnified 3 times. The tubular corolla can be dissected into 2 halves. 24 cm; 0.5 kg

E/D/H

9982-1002515



9982-1002515



9982-1000532

Dandelion (*Taraxum officinale*)

These models show:

- The inflorescence at 10 times magnification
- One seed with flight organ
- One single flower

E/D/S/F/P/I/J

9982-1000532

Genuine Chamomile (*Matricaria chamomilla*)

Model of the inflorescence (10x lifesize) with a single tubular floret (approx. 50x lifesize).

23x25x30 cm

9982-1000533



9982-1000533

Labiates (Lamiaceae)

The four sided stalks and the lip shaped flowers are characteristic of the labiates species. Labiates often are spice, perfume or medicinal flowers.



BEST SELLER



9982-1000534

Meadow Clary (*Salvia pratensis*)

This model shows the detailed structure of a single flower with its pollination mechanism (magnified approx. 15 times). For purposes of better illustration, it is possible to detach the detailed model into four components.

The typical barrier mechanism can be moved mechanically.

18x28x30 cm

9982-1000534

Fabaceae (Papilionaceae)

The name of the papilionaceae species is attributed to their butterfly shaped corolla. The corolla consists of petals, 2 wings and the keel comes from two petals which have grown together.

Pea (*Pisum sativum*)

This model shows the detailed structure of a single flower with its pollination mechanism (magnified approx. 8-fold). For purposes of better illustration, it is possible to detach the detailed model into 12 components. In addition, the cross-section of a ripe pea pod (magnified 8-fold) is depicted on the base of the model.

9982-1000535

9982-1000535

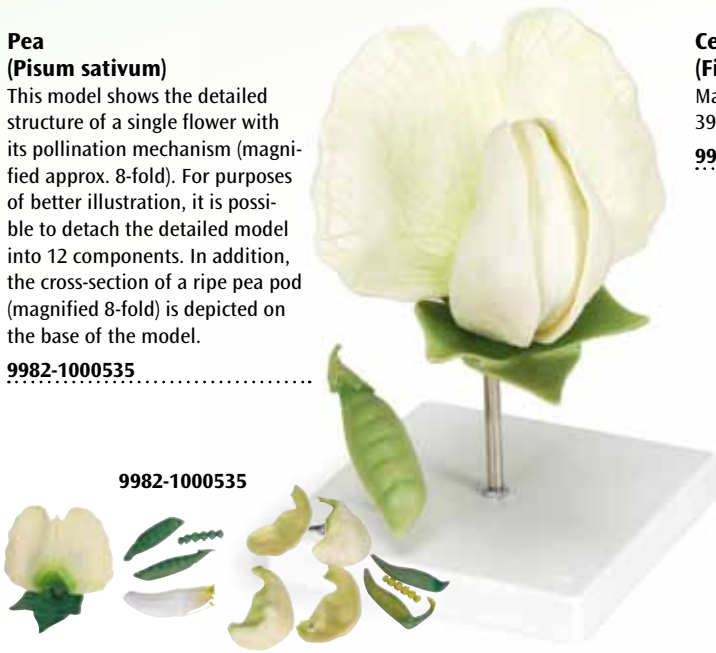

Crowfoot Plants (Ranunculaceae)

The crowfoot species includes many herbs. The flowers are often yellow.

Celandine (*Ficaria verna*)

Magnified 10 times.
39 cm; 0.4 kg

9982-1002518

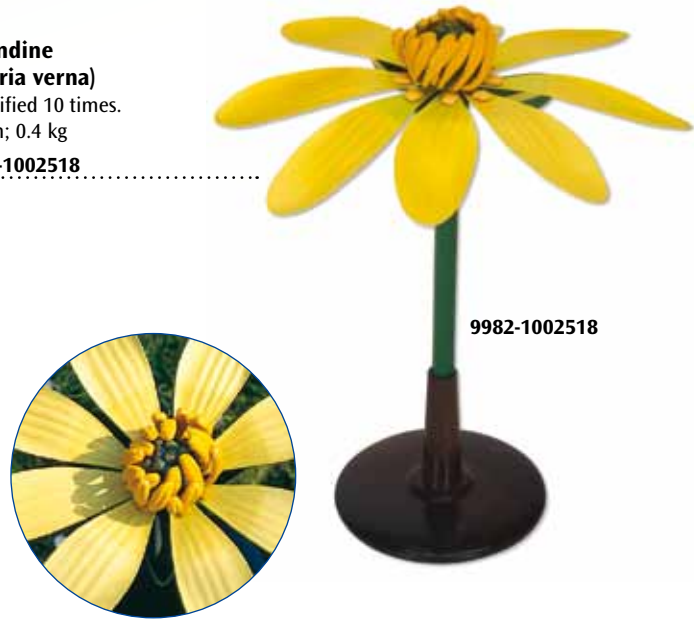

9982-1002518

Cruciferous Plants (Capparaceae)

The cruciferous plants species have earned their name because of the grape shaped flowers with 4 cross shaped sepals and petals. The fruit is often a silique.

Oilseed Rape (*Brassica napus ssp. oleifera*)

This model of a single flower (magnified 12 times) shows the typical structure of a crucifer in every detail. In addition, the cross-section of a ripe rape pod (magnified 3 times) is depicted on the base of the model.

18x18x36 cm

9982-1000531



9982-1000531

Primrose Plants (Primulaceae)

Hardies featuring rosette like, ground petals, a leafless stalk and umbel like flowers are typical of primrose species. The sepals and petals are partly grown together.



9982-1002510

9982-1002514

Wild Rape (*Sinapis arvensis*)

Model at 12 times magnification. The 2-part carpel area can be taken out for detailed study.

35 cm; 0.3 kg

9982-1002514

Primrose (*Primula veris*)

This model shows the complete flower and a longitudinal section.

39 cm; 1.2 kg

9982-1002510



Woody Plants (Hamamelididae) and Rose Plants (Rosaceae)

The species of woody plants and rose plants include trees, bushes and hardies. The rosaceae species are subdivided into 4 subfamilies: Spiraeoideae, Rosoideae, Maloideae (pomaceous fruit, e.g. apple) and Prunoideae (stone fruits, e.g. cherry). The flowers mostly feature a pentamerous perianth and numerous stamen.



9982-1000530

**BEST
SELLER**



9982-1002517

Cherry Blossom with Fruit (Prunus Avium)

This model shows the blossom of the sweet cherry (3-parts) enlarged 7 times as well as a cherry fruit enlarged 3 times. The cherry blossom can be split into two halves to reveal the removable ovary with style and stigma.

32.5 cm; 0.6 kg

E/D

9982-1000530

Apple Flower (Malus pumila)

Model at 5 times magnification showing sepals, petals, carpels and stamen.

40 cm; 0.4 kg

9982-1002517

Oak Tree Stem (Quercus robur)

This model shows male and female flowers at 25 times magnification, the section of stamen and pistils is removable.

30 cm; 1.2 kg

9982-1002513



9982-1002513

Solanum (Solanaceae)

The solanum species usually features large, bell-shaped flowers in different colours.



9982-1002516

Potato Flower (Solanum tuberosum)

8 times magnified. The part that features petals and stamen can be removed for a detailed view of the carpel.

39 cm; 0.25 kg

9982-1002516



Relief Model of Leaf Structure

Representation of the histological structure of a leaf (Ligustrum), magnified 500 times.
6.5x24x26 cm; 1.4 kg

📖 E

9982-1005129

9982-1005129



Block Model of Leaf Structure

Cube-shaped detail of the pedate, bifacial deciduous leaf of the Christmas Rose (Helleborus niger) enlarged by a factor of 1500, with stoma on the underside.
30x30x9cm; 1.4kg

📖 L/D/E/F/I/S/P/J/R/C

9982-1002504

9982-1002504

Absorption Zone of the Root

With the example of the white mustard (sinapis alba) this relief model shows the absorption zone of a dicotyledonous plant.
43x43x8 cm; 1.5 kg

📖 E/D/H

9982-1002505

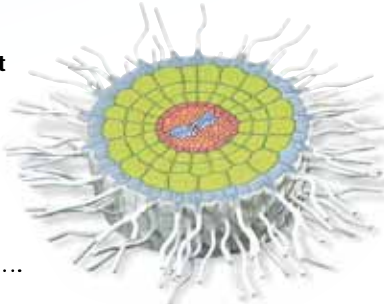

9982-1002505

Dicotyledons – Stem Cross-Section

Cross-section of a Creeping Buttercup stem with collateral open vascular bundles. The model shows the typical stem structure of a dicotyledon enlarged by a factor of 250.
28x7cm; 0.8kg

📖 L/D/E/F/I/S/P/J/R/C

9982-1002506

9982-1002506



9982-1005130

Tissue Structure of the Sunflower Stem (Helianthus annuus)

Detailed longitudinal and lateral view 200 times magnified.

📖 E

9982-1005130



9982-1005131

Tissue Structure of the Buttercup Root (Ranunculus)

Longitudinal and lateral view at 400 times magnification.

📖 E

9982-1005131

The Plant Cell, magnified 500,000-1,000,000 times

The two-piece model presents the structure of a typical plant cell with cytoplasm and cell organelles, as viewed from an electron microscope. For better illustration, all important organelles are raised and displayed in colour, e.g.:

- Cell wall
- Cell membrane
- Nucleus
- Smooth Endoplasmic Reticulum
- Rough Endoplasmic Reticulum
- Ribosomes
- Chloroplasts
- Mitochondria
- Dictyosomes/Golgi apparatus

20x14x32 cm; 0.8 kg

📖 E/D/S/F/P/I/J

9982-1000524



9982-1000524

The Animal Cell

The two-piece model shows the form and structure of a typical animal cell as viewed from an electron microscope. For better illustration, all important organelles are raised and displayed in colour, e.g.:

- Nucleus
- Mitochondrion
- Smooth Endoplasmic Reticulum (ER)
- Rough Endoplasmic Reticulum (ER)
- Basal membrane
- Collagen fibres
- Golgi apparatus
- Microvilli
- Lysosome

21x11x31 cm; 0.8 kg

📖 E/D/S/F/P/I/J

9982-1000523



9982-1000523



9982-1005124



Comparison Models Animal and Plant Cell

These enlarged models of an animal cell and a plant cell enable visual teaching about their structures, as well as their similarities and differences. The cell structures are numbered and identified, and the product manual also includes reproducible illustrations for use in testing. Furthermore, the set contains 12 electron microscopic illustrations of different cell structures. Supplied with teacher's notes in English.

16x15x9 cm; 1 kg

📖 E

9982-1005124

UNIQUE!



Human Cell

9982-1008554

Glass Cell, 40,000 times full-size

This unique model represents an undifferentiated human cell at an enlargement of 40,000 times. It provides a means of studying the structure of the smallest unit of any living creature capable of independent life, as seen through an electron microscope. The model shows the essential function bearing cell organelles. Their arrangement in the model provides a momentary snapshot of the dynamic balance of a cell. The cell nucleus, a few mitochondria and the lysosomes are shown in section, so that their internal structure is visible. The glass cell is an eye-catcher for exhibitions and has received several distinctions such as "World Didac Gold Award 1990".

Mounted on bar stand.

60x46x46 cm; 13 kg

D/E/F/S

9982-1008554



Cellular Biology Models

3B Scientific® Model Series

The three dimensional relief models are painted according to the usual colouring methods of microscopy, making the process of cell division easy to understand. The cell organelles are shown as if opened up in the lower part of the models. The models are equipped with magnets on the back so that for teaching purposes they can be easily arranged on a magnetic board in the classroom. The model series is supplied in a storage system (40x60 cm) which can be fastened to the wall. A detailed description and handouts for your lessons are included.

Mitosis Model

This newly developed 3B Scientific® model series shows the following 9 phases of mitosis on the basis of a typical mammal cell at an enlargement of approx. 10,000 times:

1. Interphase
2. Prophase
3. Early prometaphase
4. Later prometaphase
5. Metaphase
6. Early anaphase
7. Later anaphase
8. Telophase
9. Cytokinesis

60x40x6 cm; 1.5 kg

 E/D/S/F/P/J

9982-1000521

Tip: As a useful addition and permanent eye catcher in the classroom we recommend the matching wall chart "Mitosis" (page 162), product number 9982-1001206, 9982-4006548.

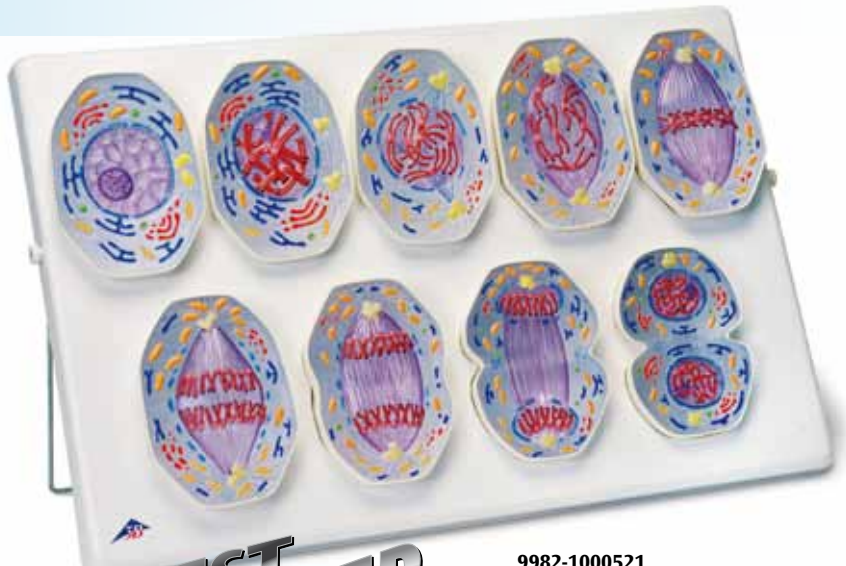

BEST SELLER

9982-1000521

Meiosis Model

This newly developed 3B Scientific® model series shows the 10 stages of meiosis on the basis of a typical mammal cell at an enlargement of approx. 10,000 times:

1. Interphase (stage of G1-phase)
2. Prophase I (leptotene)
3. Prophase I (zygotene and pachytene)
4. Prophase I (diplotene)
5. Prophase I (diakinesis)
6. Metaphase I
7. Anaphase I
8. Telophase I, cytokinesis I, interkinesis, prophase II and metaphase II
9. Anaphase II
10. Telophase II and cytokinesis II

60x40x6 cm; 1.7 kg

 E/D/S/F/P/J

9982-1000522

Tip: As a useful addition and permanent eye catcher in the classroom we recommend the matching wall chart "Meiosis" (page 162), (9982-1001210, 9982-4006550).

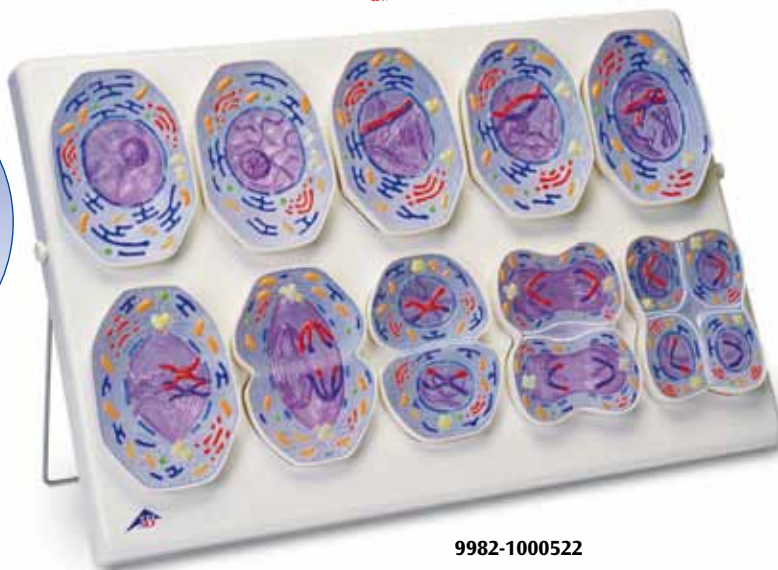

9982-1000522



9982-1005126

Meiosis, 10 Models

With 10 models the stages of meiosis are explained. Supplied with teacher's notes in English.

16x2x12 cm; 1 kg

 E

9982-1005126

Mitosis, 8 Models

This set explains the stages of mitosis with 8 enlarged models. Supplied with teacher's notes in English.

16x15x9 cm; 1 kg

 E

9982-1005125



9982-1005125

Information About Microscopes



Course Microscope

Course microscopes are robust, low-cost microscopes with basic optical features that are ideally suited for lessons in school or for beginners in microscopy.

Barrel

The barrel is the tube in which the oculars can be placed.

Monocular barrel: for observation with a single eye.

Binocular barrel: for stereo observation. This makes the work easier and less tiring than with a monocular microscope.

Trinocular barrel: for stereo observation but also allowing for addition of a camera.

Ocular

The ocular magnifies the real image thrown by the microscope's objective. The diameter of the field of vision, i.e. the area of the slide that can be viewed at one time, is calculated by dividing the field number by the scaling factor. Thus for a 10x 18 mm ocular, the viewing field has a diameter of 1.8 mm.

Objective Revolver

The objective revolver accommodates between 3 and 5 objectives and makes it possible to change the magnification rapidly when viewing a slide.

Objective

An objective produces a real image of the object. The size of the image is given by the scaling factor (e.g. 10x) and the resolution is determined by the numerical aperture (e.g. 0.65). The larger the numerical aperture the more detailed the image produced.

Achromatic objectives provide only a limited amount of correction for lens aberrations but this is nevertheless sufficient for most uses that arise in schools. Planar achromatic objectives eliminate image field curvature and throw an image that is uniformly focussed from the centre of the field of vision to the edge.

Resolution of Objectives

The resolution of an objective is given by the following formula

$$d = \frac{\lambda}{2 \cdot A}$$

where d = distance between two points, λ = wavelength of the light, A = numerical aperture

Example: numerical aperture = 0.65, λ = 0.55 μm , resolution d = 0.423 μm .

Object Stage

The object stage is the shelf upon which slides are placed for observation through a microscope. Using an x-y cross-table allows the slide to be moved by specific distances along the x and/or y axes. The scales mean that once a specific location on the slide has been found, it is easy to locate it again.

Condenser

The function of a condenser is to allow for careful adjustment of the aperture to ensure an optimum compromise between image contrast and resolution. As the aperture is made smaller, the contrast increases but the resolution is simultaneously reduced.

Coarse and Fine Focussing

Coarse and fine adjustment gears allow for optimum focussing of an image. They are mostly fitted along a common axis on either side of the column leading up from the base.

Illumination

Microscope slides can be illuminated by means of incandescent tungsten lamps, fluorescent tubes, LEDs or halogen lamps. Halogen lamps are best suited to the task because they provide such intense light. Fluorescent tubes and LEDs eliminate the problem of slides warming up due to the heat from the light during longer periods of observation.

9982-1005401
9982-1005402



9982-1005405
9982-1005406



The monocular course microscopes model 100 are distinguished by their robust construction and ease of operation. They are equipped with three achromatic objectives as used in common practice and have a simple object stage with two clips for holding slides. They can be supplemented by means of a variety of spare parts and accessories. There is a choice of two means of illumination: a tungsten lamp or low temperature LED lighting. The LED lighting makes for uniform illumination of the object and avoids the problem of heat affecting the slide when viewed for extended periods. In addition, it lasts for a long time and eliminates the need to change bulbs. The models with LED lighting are equipped with rechargeable batteries and can be used without a mains connection.

Art. No.	Description	Power Supply
9982-1005401	Model 100	115 V, 50/60 Hz
9982-1005402	Model 100	230 V, 50/60 Hz
9982-1005405	Model 100, LED	115 V, 50/60 Hz
9982-1005406	Model 100, LED	230 V, 50/60 Hz

Description	Monocular Course Microscope Model 100	Monocular Course Microscope Model 100 LED
Art. No.	9982-1005401, 9982-1005402	9982-1005405, 9982-1005406
Stand	All-metal stand, arm firmly connected with base, pinion knobs attached on both sides of the stand for coarse and fine focusing	
Tube	Monocular inclined 45°, head rotation 360°	
Eyepieces	Wide field eyepiece WF 10x 18 mm with pointer and eyepiece lock	
Objectives	Revolving nosepiece with 3 achromatic objectives 4x / 0.10, 10x / 0.25, 40x / 0.65	
Enlargement	40x, 100x, 400x	
Object Stage	110 mm x 120 mm with 2 specimen clips	
Illumination	115 V resp. 230 V, 20 W tungsten lamp integrated in base, power supply 115 V resp. 230 V 50/60 Hz	Adjustable LED lighting integrated in base, power supplied by rechargeable battery, 115 V or 230 V, 50/60 Hz charger
Condensor	Bright-field condenser N.A. 0.65, iris diaphragm, filter holder and blue filter	
Dimensions	175 mm x 135 mm x 370 mm	
Weight	2.9 kg	
Supplied	Complete with dust cover	

9982-1003266
9982-1003267
9982-1013364
9982-1013142



9982-1003268
9982-1003269
9982-1013365
9982-1013143



Course Microscopes

Course microscopes model 200 are especially robust microscopes for educational purposes. They are simple to use and their mechanical and optical quality is outstanding. Separate adjustment knobs for fine and coarse setting allow the microscopes to be focussed quickly. The low temperature lighting provides for uniform illumination of the object and avoids the problem of heat affecting the slide when observed for long periods. LED lighting also has the additional benefit of being brighter, as well as being long-lasting and eliminating the need for changing bulbs. Binocular models feature a Siedentopf head and 30° viewing angle for comfortable observation of the object.

Art. No.	Description	Power Supply
9982-1003266	Model 200	115 V, 50/60 Hz
9982-1003267	Model 200	230 V, 50/60 Hz
9982-1013364	Model 200, LED	115 V, 50/60 Hz
9982-1013142	Model 200, LED	230 V, 50/60 Hz
9982-1003268	Model 200	115 V, 50/60 Hz
9982-1003269	Model 200	230 V, 50/60 Hz
9982-1013365	Model 200, LED	115 V, 50/60 Hz
9982-1013143	Model 200, LED	230 V, 50/60 Hz

Description	Monocular Course Microscope		Binocular Course Microscope	
	Model 200	Model 200 LED	Model 200	Model 200 LED
Art. No.	9982-1003266, 9982-1003267	9982-1013364, 9982-1013142	9982-1003268, 9982-1003269	9982-1013365, 9982-1013143
Stand	Robust, all metal stand with arm permanently connected to the base. Focussing by means of separate knobs for coarse and fine adjustment located on either side of the stand and operated by rack and pinion drive with dovetail teeth, adjustable stopper for protecting the object stage and objective			
Tube	Monocular inclined 45°, head rotation 360°		Binocular Siedentopf head, 30° viewing angle, 360° rotatable head, viewing distance adjustable between 54 and 75 mm, ±5 dioptric compensation for both eyepieces	
Eyepieces	Monocular inclined 45°, head rotation 360°		Pair of wide field eyepieces WF 10x 18 mm	
Objectives	Revolving nosepiece with 3 achromatic objectives 4x / 0.10, 10x / 0.25, 40x / 0.65			
Enlargement	40x, 100x, 400x			
Object Stage	127 mm x 132 mm with 2 specimen clips			
Illumination	5 W fluorescent lamp integrated in base, power supply 115 V resp. 230 V 50/60 Hz	Adjustable LED lighting integrated in base, power supply 115 V resp. 230 V 50/60 Hz	5 W fluorescent lamp integrated in base, power supply 115 V resp. 230 V 50/60 Hz	Adjustable LED lighting integrated in base, power supply 115 V resp. 230 V 50/60 Hz
Condensor	NA 0.65 with iris diaphragm, filter holder and blue filter			
Dimensions	220 mm x 148 mm x 356 mm		282 mm x 148 mm x 357 mm	
Weight	4 kg		4.69 kg	
Supplied	Complete with dust cover			



9982-1003270
9982-1003271
9982-1013366
9982-1013127



9982-1003272
9982-1003273
9982-1013368
9982-1013144

Course microscopes model 300 are suitable for any applications that may arise in the course of advanced biology lessons. The microscopes are equipped with a cross table, a 4-way objective revolver with DIN achromatic objectives, a focussing Abbe condenser and the coaxial drive knobs are arranged as per common practice. The low temperature lighting provides for uniform illumination of the object and avoids the problem of heat affecting the slide when viewed for extended periods. LED lighting also has the benefit of being brighter, as well as being long lasting and eliminating the need for changing bulbs. Accessories include planar and semi-planar achromatic objectives and a dark-field condenser.

Art. No.	Description	Power Supply
9982-1003270	Model 300	115 V, 50/60 Hz
9982-1003271	Model 300	230 V, 50/60 Hz
9982-1013366	Model 300, LED	115 V, 50/60 Hz
9982-1013127	Model 300, LED	230 V, 50/60 Hz
9982-1003272	Model 300	115 V, 50/60 Hz
9982-1003273	Model 300	230 V, 50/60 Hz
9982-1013368	Model 300, LED	115 V, 50/60 Hz
9982-1013144	Model 300, LED	230 V, 50/60 Hz

Description	Monocular Course Microscope		Binocular Course Microscope	
	Model 300	Model 300 LED	Model 300	Model 300 LED
Art. No.	9982-1003270, 9982-1003271	9982-1013366, 9982-1013127	9982-1003272, 9982-1003273	9982-1013368, 9982-1013144
Stand	Robust, all metal stand with arm permanently connect to the base. Focussing by means of separate knobs for coarse and fine adjustment located on either side of the stand and operated by rack and pinion drive with ball bearings, adjustable stopper for protecting the object slides and objective			
Tube	Monocular inclined 30°, head rotation 360°		Binocular Siedentopf head, 30° viewing angle, 360° rotatable head, viewing distance adjustable between 54 and 75 mm, ±5 dioptic compensation for both eyepieces	
Eyepieces	Wide field eyepiece WF 10x 18 mm		Pair of wide field eyepieces WF 10x 18 mm	
Objectives	Revolving nosepiece with 4 achromatic objectives 4x / 0.10, 10x / 0.25, 40x / 0.65, 100x / 1.25 (oil)			
Enlargement	40x, 100x, 400x, 1000x			
Object Stage	x-y cross table, 125 mm x 130 mm, with object guide and coaxial adjustment knobs perpendicular to the object stage, adjustment range 70 mm x 30 mm			
Illumination	5 W fluorescent lamp integrated in base, power supply 115 V resp. 230 V 50/60 Hz	Adjustable LED lighting integrated in base, power supply 115 V resp. 230 V 50/60 Hz	5 W fluorescent lamp integrated in base, power supply 115 V resp. 230 V 50/60 Hz	Adjustable LED lighting integrated in base, power supply 115 V resp. 230 V 50/60 Hz
Condenser	Abbe condenser N.A.1.25 with iris diaphragm, filter holder and blue filter, focussed via rack and pinion drive			
Dimensions	220 mm x 154 mm x 359 mm		282 mm x 148 mm x 357 mm	
Weight	4.5 kg		5.2 kg	
Supplied	Complete with dust cover			



The microscopes model 400 are characterised by their robust design, excellent mechanical and optical quality and ease of operation. They are equipped with a large cross-stage and a 4-way objective revolver with 4 DIN achromatic objectives. 9982-1003274, 9982-1003275 and 9982-1003276 (see page 66) are also supplied with a second wide-field WF15x eyepiece as standard, allowing for various magnifications of a slide. A halogen lamp incorporated into the base makes for bright and uniform illumination of the object. Siedentopf head and 30° viewing angle for comfortable observation of the object.

Microscopes 9982-1003276 and 9982-1003277 (see page 66) provide for binocular or monocular viewing as well as allowing simultaneous fitting of a camera for photographic or video recording of the image.

Art. No.	Description
9982-1003274	Model 400, Monocular
9982-1003275	Model 400, Binocular

Description	Monocular Microscope, Model 400	Binocular Microscope, Model 400
Art. No.	9982-1003274	9982-1003275
Stand	Robust, all metal stand with arm permanently connected to the base. Focussing by means of separate knobs for coarse and fine adjustment located on either side of the stand and operated by rack and pinion drive with ball bearings and retaining lever, adjustable stopper for protecting the object slides and objective. Focus range: 15mm, Resolution of fine focussing adjustment: 0.002 mm	
Tube	Monocular inclined 30°, head rotation 360°	Binocular Siedentopf head, 30° viewing angle, 360° rotatable head, viewing distance adjustable between 54 and 75 mm, ±5 dioptic compensation for both eyepieces
Eyepieces	Wide field eyepieces WF 10x 18 mm and WF 15x 13 mm	Pair of wide field eyepieces WF 10x 18 mm and WF 15x 13 mm
Objectives	Revolving nosepiece with 4 achromatic objectives 4x / 0.10, 10x / 0.25, 40x / 0.65, 100x / 1.25 (oil)	
Enlargement	40x – 1500x	
Object Stage	x-y mechanical stage, 132 mm x 145 mm, with object guide and coaxial adjustment knobs perpendicular to the object stage, adjustment range 76 mm x 50 mm	
Illumination	Adjustable 6 V, 20 W halogen lamp integrated in base, universal 85 to 265 V, 50/60 Hz power supply	
Condenser	Abbe condenser N.A.1.25 with iris diaphragm, filter holder and blue filter, focussed via rack and pinion drive	
Dimensions	291 mm x 214 mm x 356 mm	328 mm x 214 mm x 394 mm
Weight	5.6 kg	6.1 kg
Supplied	Complete with dust cover	



9982-1003277

9982-1003276

The microscopes model 400 are characterised by their robust design, excellent mechanical and optical quality and ease of operation. They are equipped with a large cross-stage and a 4-way objective revolver with 4 DIN achromatic objectives. 9982-1003274, 9982-1003275 (see page 65) and 9982-1003276 are also supplied with a second wide-field WF15x eyepiece as standard, allowing for various magnifications of a slide. A halogen lamp incorporated into the base makes for bright and uniform illumination of the object. Siedentopf head and 30° viewing angle for comfortable observation of the object.

Microscopes 9982-1003276 and 9982-1003277 provide for binocular or monocular viewing as well as allowing simultaneous fitting of a camera for photographic or video recording of the image.

Art. No.	Description
9982-1003277	Model 400, Monocular, vertical viewing
9982-1003276	Model 400, Trinocular

Description	Monocular Microscope Model 400 with Vertical Viewing	Trinocular Microscope Modell 400
Art. No.	9982-1003277	9982-1003276
Stand	Robust, all metal stand with arm permanently connected to the base. Focussing by means of separate knobs for coarse and fine adjustment located on either side of the stand and operated by rack and pinion drive with ball bearings and retaining lever, adjustable stopper for protecting the object slides and objective. Focus range: 15 mm, Resolution of fine focussing adjustment: 0.002 mm	
Tube	Head with double viewing capability, one tube with 30° viewing angle, one with vertical viewing, head rotation 360°	Trinocular Siedentopf head, 360° rotatable, binocular tubus with 30° viewing angle, viewing distance adjustable between 54 and 75 mm, ±5 dioptric compensation for both eyepieces, one tube with vertical viewing angle
Eyepieces	Pair of wide field eyepieces WF 10x 18 mm	Pair of wide field eyepieces WF 10x 18 mm and WF 15x 13 mm
Objectives	Revolving nosepiece with 4 achromatic objectives 4x / 0.10, 10x / 0.25, 40x / 0.65, 100x / 1.25 (oil)	
Enlargement	40x, 100x, 400x, 1000x	40x – 1500x
Object Stage	x-y mechanical stage, 132 mm x 145 mm, with object guide and coaxial adjustment knobs perpendicular to the object stage, adjustment range 76 mm x 50 mm	
Illumination	Adjustable 6 V, 20 W halogen lamp integrated in base, universal 85 to 265 V, 50/60 Hz power supply	
Condensor	Abbe condenser N.A.1.25 with iris diaphragm, filter holder and blue filter, focussed via rack and pinion drive	
Dimensions	291 mm x 214 mm x 415 mm	328 mm x 214 mm x 449 mm
Weight	5.8 kg	6.2 kg
Supplied	Complete with dust cover	



9982-1013151



9982-1013150

Adjustable LED Lighting

The trinocular microscopes models N110 and N180 are characterised by their robust design and their excellent optical and mechanical qualities. Their vertical tubes allow cameras to be attached for documenting work in the form of photographs and videos and make it possible for specimens to be viewed through the ocular and on a computer screen at the same time. Low temperature LED lighting ensures even illumination of the field of vision, prevents heat affecting specimens that are viewed for long periods as well as being long lasting and eliminating the need for changing bulbs. Model N180 is equipped with an extra wide-field ocular with a “high eye point”, making it especially suitable for those who wear spectacles and providing a broad field of vision. It is equipped with a semi-planar achromatic objective, allowing observation of tiny features in excellent detail, while making it possible to maintain evenness of focus from the centre to the edges of the field of vision.

Art. No.	Description
9982-1013151	Model N110, Trinocular
9982-1013150	Model N180, Trinocular

Description	Trinocular Microscope Model N110	Trinocular Microscope Model N180
Art. No.	9982-1013151	9982-1013150
Stand	Robust, all metal stand with arm permanently connected to the base. Focussing by means of separate knobs for coarse and fine adjustment located on either side of the stand	
Tube	Trinocular Siedentopf head, 360° rotatable, binocular tubus with 30° viewing angle, viewing distance adjustable between 55 and 75 mm, ±5 dioptic compensation, one tube with vertical viewing angle to attach a camera	
Eyepieces	Pair of wide field eyepieces WF 10x 18 mm	Pair of extra wide field eyepieces EW 10x 20 mm
Objectives	Revolving nosepiece with 4 achromatic objectives 4x / 0.10, 10x / 0.25, 40x / 0.65, 100x / 1.25 (oil)	Inverted objective revolver with 4 semi plan achromatic objectives 4x / 0.10, 10x / 0.25, 40x / 0.65, 100x / 1.25 (oil)
Enlargement	40x, 100x, 400x, 1000x	
Object Stage	x-y mechanical stage, 132 mm x 145 mm, with object guide and coaxial adjustment knobs perpendicular to the object stage, adjustment range 78 mm x 54 mm	x-y mechanical stage, 140 mm x 140 mm, with object guide and coaxial adjustment knobs perpendicular to the object stage, adjustment range 75 mm x 50 mm
Illumination	Adjustable LED lighting integrated in base, universal 100 to 240 V, 50/60 Hz power supply	
Condenser	Abbe condenser N.A.1.25 with iris diaphragm, filter holder and filter	
Dimensions	291 mm x 214 mm x 415 mm	
Weight	8 kg	7.2 kg
Supplied	Complete with dust cover	

NEW**LED Illumination****NEW****LED Illumination**9982-1003278
9982-10131459982-1003279
9982-1013146**Top Quality**

The microscopes model 500 are suitable for any applications that may arise in the course of advanced biology lessons. Their compact and ergonomic design facilitates ease of working with the microscope. They are equipped as standard with a polarisation fitting and have a large cross table, 2 pairs of wide-field eyepieces (WF 10x, WF 15x) and a four-way objective revolver with planar achromatic objectives, for outstanding observation of tiny details with uniform focus from centre to edge of field of view. There is a choice of two means of illumination: halogen lighting or low temperature LED illumination. The LED lighting prevents heat affecting the specimen when viewed for extended periods, as well as being long lasting and eliminating the need to change bulbs.

Art. No.	Description
9982-1003278	Model 500, Monocular
9982-1013145	Model 500, Monocular, LED
9982-1003279	Model 500, Monocular
9982-1013146	Model 500, Monocular, LED

Description	Monocular Microscope Model 500 with Polarisation Equipment	Monocular Microscope Model 500 LED with Polarisation Equipment
Art. No.	9982-1003278, 9982-1013145	9982-1003279, 9982-1013146
Stand	Robust, all metal stand with arm permanently connected to the base. Focussing by means of separate knobs for coarse and fine adjustment located on either side of the stand and operated by rack and pinion drive with ball bearings and retaining lever, adjustable stopper for protecting the object slides and objective. Focus range: 15 mm, Resolution of fine focussing adjustment: 0.002 mm	
Tube	Monocular inclined 30°, head rotation 360°	Binocular Siedentopf head, 30° viewing angle, 360° rotatable head, viewing distance adjustable between 54 and 75 mm, ±5 dioptic compensation for both eyepieces
Polarisation equipment	Polariser and analyser	
Eyepieces	Wide field eyepieces WF 10x 18 mm and 15x 13 mm	Pair of wide field eyepieces WF 10x 18 mm and 15x 13 mm
Objectives	Inverted objective revolver with 4 plan achromatic objectives 4x / 0.10, 10x / 0.25, 40x / 0.65, 100x / 1.25 (oil)	
Enlargement	40x – 1500x	
Object Stage	x-y mechanical stage, 155 mm x 145 mm, with object guide and coaxial adjustment knobs perpendicular to the object stage, adjustment range 76 mm x 50 mm	
Illumination	Adjustable 6 V, 20 W halogen lamp integrated in base, universal 85 to 265 V, 50/60 Hz power supply	Adjustable LED lighting integrated in base, universal 85 to 265 V, 50/60 Hz power supply
Condensor	Abbe condenser N.A.1.25 with iris diaphragm, filter holder and blue filter, focussed via rack and pinion drive	
Dimensions	256 mm x 190 mm x 378 mm	306 mm x 190 mm x 407 mm
Weight	6 kg	6.6 kg
Supplied	Complete with dust cover	



9982-1012403



9982-1012404

High quality mechanics and optics along with ease of operation are the outstanding features of the polarisation microscopes 9982-1012403 and 9982-1012404. Their compact and ergonomic design makes it easier to work with them. The main application for these microscopes is in mineralogy where they are used to study rock specimens, identify minerals and investigate crystals. They may also be used in biology, though, for instance when studying the structure of starch grains, the texture of cellulose fibres in cell walls or the position of rod-like viruses in cells (e.g. tobacco mosaic virus).

Art. No.	Description
9982-1012403	Monocular Polarisation Microscope
9982-1012404	Binocular Polarisation Microscope

Description	Monocular Polarisation Microscope	Binocular Polarisation Microscope
Art. No.	9982-1012403	9982-1012404
Stand	Robust, all metal stand with arm permanently connected to the base. Focussing by means of separate knobs for coarse and fine adjustment located on either side of the stand and operated by rack and pinion drive with ball bearings and retaining lever, adjustable stopper for protecting the object slides and objective.	
Tube	Monocular inclined 30°, head rotation 360°	Binocular head, 30° viewing angle, 360° rotatable head, viewing distance adjustable between 54 and 75 mm, ±5 dioptic compensation for both eyepieces
Polarisation equipment	Polariser with scale and analyser, which can be inserted into the tube.	
Eyepieces	Wide field eyepiece WF 10x 18 mm	Pair of wide field eyepieces WF 10x 18 mm
Objectives	Inverted objective revolver with 3 achromatic objectives 4x / 0.10, 10x / 0.25, 40x / 0.65	
Enlargement	40x – 400x	
Object Stage	Circular object stage 120 mm in diameter, which can be rotated 360°, scale with Vernier and 2 specimen clips	
Illumination	Adjustable 6 V, 20 W halogen lamp integrated in base, universal 85 to 265 V, 50/60 Hz power supply	
Condenser	Abbe condenser N.A.1.25 with iris diaphragm, focussed via rack and pinion drive	
Dimensions	240 mm x 190 mm x 385 mm	240 mm x 190 mm x 425 mm
Weight	5.5 kg	6 kg
Supplied	Complete with dust cover	



9982-1013152

NEW

9982-1013153

NEW
with camera

Digital microscopes 9982-1013152 and 9982-1013153 are characterised by their robust design, their fine optical and mechanical properties and their ease of operation. The built-in 1.3-megapixel camera allows specimens to be viewed through the ocular and on a computer screen at the same time and provides well-focused images with authentic colour. There is a choice of two models: a monocular microscope with low temperature LED illumination and a binocular microscope using a halogen lamp. Professional “ScopelImage” software allows both static images and videos to be recorded as well as featuring image editing plus measurement and evaluation capabilities.

Art. No.	Description
9982-1013152	Digital Monocular Microscope
9982-1013153	Digital Binocular Microscope

Description	Digital Monocular Microscope with built-in Camera	Digital Binocular Microscope with built-in Camera
Art. No.	9982-1013152	9982-1013153
Stand	All-metal stand, arm firmly connected with base, pinion knobs attached on both sides of the stand for coarse and fine focusing	
Tube	Monocular inclined 45°, head rotation 360°	Binocular inclined 45°, head rotation 360°
Eyepieces	Wide field eyepiece WF 10x 18 mm	Pair of wide field eyepieces WF 10x 18 mm
Objectives	Revolving nosepiece with 3 achromatic objectives 4x / 0.10, 10x / 0.25, 40x / 0.65	Revolving nosepiece with 4 achromatic objectives 4x / 0.10, 10x / 0.25, 40x / 0.65, 100x / 1.25 (oil)
Enlargement	40x, 100x, 400x	40x, 100x, 400x, 1000x
Object Stage	x-y mechanical stage, 125 mm x 115 mm, with object guide, adjustment range 70 mm x 20 mm	x-y mechanical stage, 140 mm x 140 mm, with object guide, adjustment range 75 mm x 50 mm
Illumination	Adjustable LED lighting integrated in base. Universal 100 V to 240 V, 50/60 Hz power supply	Adjustable 6 V, 20 W halogen lamp integrated in base. Universal 100 V to 240 V, 50/60 Hz power supply
Condensor	Abbe condenser N.A.1.25 with iris diaphragm, filter holder and filter	
Camera Sensor	1/3" CMOS, 1.3 Mpixel, colour image	
Power Supply	Via USB 2.0	
System Requirements	WIN2000, WINXP and Vista	
Weight	2.5 kg	8.5 kg
Supplied	Complete with dust cover	

The digital course microscopes with integrated camera 9982-1005403 and 9982-1005404 are distinguished by their robust construction and ease of operation. They are equipped with three achromatic objectives as used in common practice and have a simple object stage with two clips for holding slides. They can be supplemented by means of a variety of spare parts and accessories. The LED lighting makes for uniform illumination of the object and avoids the problem of heat affecting the slide when viewed for extended periods. The microscopes are equipped with rechargeable batteries and can be used without a mains connection. A 2-megapixel colour camera is built in to the microscope. The user-friendly "Photolib" software allows for...

- Full screen real time video
- Image processing
- Image plane processing
- Noise reduction filter for image enhancement, user-defined filter
- False colour image display
- 3D representation
- Extensive evaluation and measurement options

Description	Digital Course Microscope Model 100, LED with Built-in Camera
Art. No.	9982-1005403, 9982-1005404
Stand	All metal stand, arm firmly connected with base, pinion knobs attached on both sides of the stand for coarse and fine focusing
Tube	Monocular inclined 45°, head rotation 360°
Eyepieces	Wide field eyepiece WF 10x 18 mm with pointer and eyepiece lock
Objectives	Revolving nosepiece with 3 achromatic objectives 4x / 0.10, 10x / 0.25, 40x / 0.65
Enlargement	40x, 100x, 400x
Object Stage	110 mm x 120 mm with 2 specimen clips
Illumination	Adjustable LED lighting integrated in base, power supplied by rechargeable battery, 115 V or 230 V, 50/60 Hz charger
Condensor	Bright-field condenser N.A. 0.65, iris diaphragm, filter holder and blue filter
Camera Sensor	1/3" 2 Mpixel, colour image
Power Supply	Via USB 2.0
System Requirements	WIN95, WIN98, WIN2000 and WINXP
Dimensions	175 mm x 135 mm x 370 mm
Weight	2.9 kg
Supplied	Complete with dust cover

Art. No.	Description	Power Supply
9982-1005403	Digital Course Microscope	115 V, 50/60 Hz
9982-1005404	Digital Course Microscope	230 V, 50/60 Hz



9982-1005403
9982-1005404

Microscopes with Built-In Camera / Laboratory Microscope



9982-1005455

The 9982-1005455 microscope is intended for exacting analysis using bright-field transmitted light. Its ergonomic design allows for lengthy periods of use without tiring. The high-quality infinite optical system guarantees excellent image quality.

9982-1005455

Description	Laboratory Microscope BS-200
Art. No.	9982-1005455
Stand	Robust and stable all metal stand, pinion knobs attached on both sides of the stand for coarse and fine focusing with friction coupling
Tube	Binocular at 45° angle, rotatable through 360°
Eyepieces	Pair of eyepieces PL10x 20 mm with infinite optics
Objectives	Inverted objective revolver with plan achromatic infinite objectives 4x, 10x, 40xS und 100xS Oil
Enlargement	40x – 1000x
Object Stage	x-y mechanical stage, 150 mm x 140 mm, adjustment range 76 mm x 50 mm
Illumination	Adjustable 6 V, 20 W halogen lamp, built-in transformer for 90 to 240 V mains voltage
Condensor	Condenser NA1.25, iris diaphragm, filter holder and blue filter
Supplied	Complete with dust cover

Microscopy



9982-1005432
9982-1005433



9982-1005434
9982-1005435



9982-1005442
9982-1005443

Stereo microscopes model 20x are robust microscopes that are distinguished by their ease of operation and excellent mechanical and optical quality. They can be used in numerous applications within the fields of biology and geology. They are equipped with a quick-change fitting that allows for rapid replacement of the objective. With the aid of accessories, a magnification of up to 120x can be achieved. There is a choice of two illumination sources: plain reflected illumination plus reflected and transmitted light and a mixture of the two. It is also possible to choose between conventional illumination with a light bulb and low-temperature LED illumination. The low-temperature illumination allows samples to be viewed for longer without heat affecting the prepared specimen. It also has the advantage of being brighter, as well as being longer lasting and eliminating the need to change bulbs. Power is supplied to the LED illumination via rechargeable batteries, so that the microscope can also be used without a mains connection.

Art. No.	Description	Power Supply
9982-1005432	Stereo Microscope	115 V, 50/60 Hz
9982-1005433	Stereo Microscope	230 V, 50/60 Hz
9982-1005434	Stereo Microscope	115 V, 50/60 Hz
9982-1005435	Stereo Microscope	230 V, 50/60 Hz
9982-1005442	Stereo Microscope	115 V, 50/60 Hz
9982-1005443	Stereo Microscope	230 V, 50/60 Hz

Description	Stereo Microscope, 20x, Top-Light	Stereo Microscope, 20x, Transmitted-Light	Stereo Microscope, 20x, Transmitted-Light LED
Art. No.	9982-1005432, 9982-1005433	9982-1005434, 9982-1005435	9982-1005442, 9982-1005443
Stand	Metal stand, column firmly connected with base, pinion knobs attached on both sides of the stand for coarse and fine focusing		
Tube	Binocular inclined 45°, interocular distance adjustable between 55 and 75 mm		
Eyepieces	Pair of wide field eyepieces WF 10x 20 mm with eyepiece lock and rubber eyepiece cups, diopter compensation ±5 on the left eyepiece		
Objectives	Lens 2x with slide and quick-change device		
Enlargement	20x		
Object Plate	Base with detachable object plate (plastic, black/white) 60 mm dia. and 2 specimen clips	Base with detachable object plates (plastic, black/white and glass) 95 mm dia. and 2 specimen clips	
Illumination	Top-light illumination, 12 V, 10 W lamp, power supply 115 V resp. 230 V 50/60 Hz	Top-, transmitted- and mixed-light illumination, 12 V, 10 W lamp, power supply 115 V resp. 230 V 50/60 Hz	LED, top-, transmitted- and mixed-light illumination, power supplied by rechargeable battery, 115 V resp. 230 V, 50/60 Hz charger
Dimensions	170 mm x 300 mm x 115 mm	190 mm x 300 mm x 115 mm	
Weight	2.4 kg	2.9 kg	
Supplied	Complete with dust cover		



9982-1005436
9982-1005437



9982-1005438
9982-1005439

**BEST
SELLER**



9982-1013369
9982-1013128

cordless

NEW
*Top-, Transmitted-
and Mixed-Light LED*

Stereo Microscopes

Stereo microscopes model 40x are robust microscopes that are distinguished by their ease of operation and excellent mechanical and optical quality. They can be used in numerous applications within the fields of biology and geology. Simply by rotating the objective from the 2x setting to 4x, the overall magnification can be set to 20x or 40x. With the aid of accessories, a magnification of up to 80x can be achieved. There is a choice of two illumination sources: plain reflected illumination plus reflected and transmitted light and a mixture of the two. It is also possible to choose between conventional illumination with a light bulb and low-temperature LED illumination. The low-temperature illumination allows samples to be viewed for longer without heat affecting the prepared specimen. It also has the advantage of being brighter, as well as being longer lasting and eliminating the need to change bulbs. Power is supplied to the LED illumination via rechargeable batteries, so that the microscope can also be used without a mains connection.

Art. No.	Description	Power Supply
9982-1005436	Stereo Microscope	115 V, 50/60 Hz
9982-1005437	Stereo Microscope	230 V, 50/60 Hz
9982-1005438	Stereo Microscope	115 V, 50/60 Hz
9982-1005439	Stereo Microscope	230 V, 50/60 Hz
9982-1013369	Stereo Microscope	115 V, 50/60 Hz
9982-1013128	Stereo Microscope	230 V, 50/60 Hz

Description	Stereo Microscope, 40x, Top- Light Illumination	Stereo Microscope, 40x, Transmitted-Light Illumination	Stereo Microscope, 40x, Transmitted-Light Illumination LED
Art. No.	9982-1005436, 9982-1005437	9982-1005438, 9982-1005439	9982-1013369, 9982-1013128
Stand	Metal stand, column firmly connected with base, pinion knobs attached on both sides of the stand for coarse and fine focusing		
Tube	Binocular inclined 45°, interocular distance adjustable between 55 and 75 mm		
Eyepieces	Pair of wide field eyepieces WF 10x 20 mm with eyepiece lock and rubber eyepiece cups, diopter compensation ±5 on the left eyepiece	Pair of wide field eyepieces WF 10x 20 mm with eyepiece lock and rubber eyepiece cups, diopter compensation ±5 on the left eyepiece, one eyepiece with pointer	
Objectives	Revolving nosepiece with objective 2x / 4x		
Enlargement	20x/40x		
Object Plate	Base with detachable object plate (plastic, black/white) 60 mm dia. and 2 specimen clips	Base with detachable object plates (plastic, black/white and glass) 95 mm dia. and 2 specimen clips	
Illumination	Top-light illumination, 12 V, 10 W lamp, power supply 115 V resp. 230 V 50/60	Top-, transmitted- and mixed-light illumination, 12 V, 10 W lamp, power supply 115 V resp. 230 V 50/60 Hz	LED, top-, transmitted- and mixed-light illumination, power supplied by rechargeable battery, 115 V resp. 230 V, 50/60 Hz charger
Dimensions	170 mm x 300 mm x 115 mm	190 mm x 300 mm x 115 mm	
Weight	2.4 kg	2.9 kg	
Supplied	Complete with dust cover		

Microscopy



9982-1005440
9982-1005441



9982-1013370
9982-1013147

The stereo microscopes model 40x with rotatable head are identical in design and optical properties to the stereo microscopes 40x transmitted-light illumination and LED except for the 360° rotating stereo head.

Art. No.	Description	Power Supply
9982-1005440	Stereo Microscope	115 V, 50/60 Hz
9982-1005441	Stereo Microscope	230 V, 50/60 Hz
9982-1013370	Stereo Microscope	115 V, 50/60 Hz
9982-1013147	Stereo Microscope	230 V, 50/60 Hz

Description	Stereo Microscope, 40x, Rotatable Head	Stereo Microscope, 40x, LED, Rotatable Head
Art. No.	9982-1005440, 9982-1005441	9982-1013370, 9982-1013147
Stand	Metal stand, column firmly connected with base, pinion knobs attached on both sides of the stand for coarse and fine focusing	
Tube	Binocular inclined 45°, interocular distance adjustable between 55 and 75 mm, head rotatable by 360°	
Eyepieces	Pair of wide field eyepieces WF 10x 20 mm with eyepiece lock and rubber eyepiece cups, diopter compensation ±5 on the left eyepiece	
Objectives	Revolving nosepiece with objective 2x / 4x	
Enlargement	20x/40x	
Object Plate	Base with detachable object plates (plastic, black/white and glass) 95 mm dia. and 2 specimen clips	
Illumination	Top, transmitted and mixed-light illumination, 12 V, 10 W lamp, power supply 115 V resp. 230 V 50/60 Hz	LED, top, transmitted and mixed-light illumination, power supplied by rechargeable battery, 115 V resp. 230 V, 50/60 Hz charger
Dimensions	190 mm x 300 mm x 115 mm	
Weight	2.9 kg	
Supplied	Complete with dust cover	



9982-1013373
9982-1013376



9982-1013377
9982-1013378

NEW

The rugged 45x stereo-zoom microscope models are characterised by their ease of operation and their fine optical and mechanical qualities. They are equipped with a 0.7x to 4.5x zoom objective allowing magnifications from 7 to 45 times the original size. The ocular features a “high eye point”, making them highly suitable for those who wear spectacles. Two halogen lights for reflected and transmitted illumination which can be activated independently ensure that the object is evenly lit with uniformly bright light. Thanks to the fine optical equipment the stereo-zoom microscopes provide a very bright, distortion free image with excellent resolution. The vertical orientation of the 45x trinocular model makes it possible to fit a camera in order to document results in the form of static photographs or videos.

Art. No.	Description	Power Supply
9982-1013373	Stereo-Zoom Microscope	115 V, 50/60 Hz
9982-1013376	Stereo-Zoom Microscope	230 V, 50/60 Hz
9982-1013377	Stereo-Zoom Microscope	115 V, 50/60 Hz
9982-1013378	Stereo-Zoom Microscope	230 V, 50/60 Hz

Description	Stereo-Zoom Microscope, 45x	Stereo-Zoom Microscope, 45x, Trinocular
Art. No.	9982-1013373, 9982-1013376	9982-1013377, 9982-1013378
Stand	Metal stand, column firmly connected with base, pinion knobs attached on both sides for coarse and fine focusing	
Tube	Binocular inclined 45°, interocular distance adjustable between 54 and 75 mm, head rotatable by 360°	Binocular inclined 45° and vertical tube, interocular distance adjustable between 54 and 75 mm, head rotatable by 360°
Eyepieces	Pair of wide field eyepieces WF 10x 20 mm with eyepiece lock and rubber eyepiece cups	
Objectives	Zoom objective, 0.7x to 4.5x	
Enlargement	7x to 45x	
Diameter of Image Field	4,4 mm to 28,6 mm	
Distance from Specimen	100 mm	
Maximum Height of Object	80 mm	
Object Plate	Base with detachable object plates (plastic, black/white and glass) 95 mm dia. and 2 specimen clips	
Illumination	Top-, transmitted- and mixed-light illumination, adjustable 12 V, 15 W halogen lamp, power supply 115 V resp. 230 V 50/60 Hz	
Supplied	Complete with dust cover	

HD Video Flex®

Robust, ultra high resolution desktop digital colour camera for direct connection to a PC or notebook via a USB interface. Thanks to the ball and socket bearing, video head that can pivot and swivel via its flexible gooseneck, the camera can be easily and accurately connected, e.g. to microscopes and telescopes, or directed towards visual material, running processes or items of scientific or technical interest so that they can be viewed on a monitor. The heavy, triangular base ensures the necessary stability. Audio recordings are possible via a microphone equipped computer. An external power supply is not necessary as the camera is powered via the USB connection. Includes microscope adapter, Discovery Scope Kit, Applied Vision™ software and carrying case. Compatible with interactive whiteboards. The Applied Vision™ software for picture recording, reproduction and processing is characterized by its user friendliness and features e.g.

- Full screen, real time video
- Still frame recording
- Recording of films in AVI format
- Time-lapse recording
- Internet streaming
- Can be used in local network
- Zoom function
- Image processing
- Brightness, contrast control and positive/negative image display
- Drawing tools
- Organizer/memo function
- Printout of real time images
- Memory function (jpeg, bmp, tiff)
- Choice of background
- Creation of image collages
- Comparison of two adjacent images
- Measurement of the distance between 2 points or the area of a circle
- Exporting data to an Excel spreadsheet or MS Word
- Compatible with Windows, Mac and Linux
- Free software updates
- Unlimited local licences

9982-1012828



	9982-1012828	9982-1003436	9982-1012834	9982-1012643	9982-1012835
Photosensitivity	8 lux	20 lux	20 lux	3 lux	2 integrated white LEDs
Image Digitization	digital CMOS	digital CMOS	¼" CMOS	¼" CCD	digital CMOS
Output Signal	digital / USB 2.0	digital / USB 2.0	digital / USB 2.0	S-Video / USB 2.0	digital / USB 2.0
Resolution	HD 1080P	1280x960 SXGA	1280x1024	640x480	2048x1536
Live Video	up to 30 images per second	up to 30 images per second	up to 30 images per second	up to 30 images per second	up to 30 images per second
TV System	–	–	–	PAL	–
Microphone	–	–	–	–	yes
Lens	8 mm HD	6 mm glass	glass f = 2.8 and 1.729 mm	8 mm glass, D-mount	F2.8 coated
Focal Distance	6 mm to infinity	8 mm to infinity		6 mm to infinity	100 mm to infinity
Focus	manual	manual	auto	manual	auto
Microscope Adapter	34,5 mm built-in and 28 mm	34,5 mm built-in and 28 mm	34,5 mm built-in and 28 mm	26 mm, 28 mm, 34 mm	yes
Power Supply	via USB	via USB	via USB	via USB	via USB
Cable	USB connecting cable, approx. 150 cm	USB connecting cable, approx. 150 cm	USB connecting cable, approx. 170 cm	USB connecting cable, approx. 180 cm	USB connecting cable, approx. 180 cm
Dimensions	approx. 180x180x720 mm ³	approx. 180x180x640 mm ³	approx. 180x180x640 mm ³	approx. 180x190x560 mm ³	approx. 200x200x630 mm ³
Weight	approx. 4.55 kg	approx. 1.7 kg	approx. 1.65 kg	approx. 1.8 kg	approx. 2.04 kg

FlexCam® 2

This modern document camera with high definition (HD) resolution can do the job of multiple presentation devices, e.g. overhead projectors, opaque projectors or slide projectors. Documents, pictures, objects etc. can be laid directly onto the flat base under the camera. The two bright white LEDs integrated into the head of the camera provide excellent illumination of the field of view. A built-in microphone allows sound recordings to be made. Includes microscope adapter and Applied Vision™ software.

9982-1012835

iCam Digital

This innovative, inexpensive desk-top colour video camera is the perfect instrument for the presentation of various objects, images and text, for making video portfolios and sending video e-mails. The camera has video (PAL), S-video and USB outputs, so that it is easy to connect it to televisions as well as Mac or Windows computers, video recorders and LCD projectors. The iCam Digital camera is particularly suitable for microscope images. The focussing ring exactly matches the supplied microscope adapter. Includes Applied Vision™ software. NTSC version available on request.

9982-1012643

Vision Viewer™

Lighter version of the HD Video Flex® (9982-1012828) with similar optical properties and for the same applications. The difference is that the video head is directly attached to the gooseneck arm (with no universal joint). Compatible with interactive whiteboards. Includes a microscope adapter, observation set (Discovery Scope Kit) and Applied Vision™ software.

9982-1003436

Auto Focus Vision Viewer™

High resolution, easy-to-use, desk-top colour video camera with a host of uses. Particularly suitable for presenting printed text, images and other objects or even dynamic processes. Includes auto-focus camera lens and wide field of vision (43x36 cm), flexible gooseneck support and integrated USB cable. Compatible with interactive whiteboards. Includes microscope adapter and Applied Vision™ software.

9982-1012834



NEW

9982-1012835



NEW

9982-1012643



9982-1003436



9982-1012834

NEW



9982-1003259

Digital Camera for Microscope, 1.3 Mpixel

High-resolution colour digital camera for connecting directly to a PC or laptop via the USB interface. The camera can be mounted directly onto the eyepiece of every conventional microscope. The camera is fed via the USB connection, thereby making external power supply superfluous. Separate software "ScopePhoto" for image pickup and recording, display and processing. The software is characterised by being particularly user-friendly and is responsible for making possible, among other things:

- Full screen real time video
- Still picture recording
- Recording films in AVI format
- Adjusting image sequence and recording time
- Zoom function
- Image processing (similar to conventional image processing programs)
- Brightness and contrast control
- Real-time image printing
- Memory function (jpeg, bmp, tiff etc.)
- Gradation curves
- Tonal value correction
- FFT function
- Image plane processing
- Comparison of two adjacent images
- Noise reduction filter for image enhancement, user-defined filter
- False colour image display
- 3D representation
- Extensive evaluation and measurement options

9982-1003259



9982-1013380

NEW

9982-1013379

NEW**Student Digital Camera for Microscope, 2 Mpixel**

Inexpensive digital colour camera for use in class which can be placed directly on any modern microscope tube. The user-friendly "MiniSee" software allows for real-time video and still pictures to be recorded and stored in all formats currently in use.

9982-1013380

Digital Camera for Microscope, 8 Mpixel

Digital colour camera for microscopes with higher resolution than 9982-1003259. One advantage of the camera is that when the viewing field of the microscope is too dark to see with the naked eye, the camera can still provide a bright, highly detailed image. It is thus highly suited to dark-field microscopy and for microscopes equipped with fluorescent illumination. For software specification see 9982-1003259.

9982-1013379

Art. No.	9982-1003259	9982-1013379	9982-1013380
Camera Sensor	1/2" CMOS, colour image	1/2.5" CMOS, colour image	1/3" CMOS, colour image
Pixel Size	5.2 µm x 5.2 µm	1.75 µm x 1.75 µm	2.8 µm x 2.8 µm
Sensitivity (V/Lux-sec)	1.8	1.3	1.0
Resolution	1280 x 1024 1.3 Mpixel	3264 x 2448 8 Mpixel	1600 x 1200 2 Mpixel
Dynamic Range	65 dB	75 dB	71 dB
Wave Length	400 – 650 nm	400 – 650 nm	400 – 650 nm
Exposure	ERS (Electronic Rolling Snap)	ERS (Electronic Rolling Snap)	ERS (Electronic Rolling Snap)
White Balance	automatic / manual	automatic / manual	automatic / manual
Output	USB 2.0	USB 2.0	USB 2.0
Programmable Control	image size, brightness, gain, exposure time	image size, brightness, gain, exposure time	image size, brightness, gain, exposure time
Power Supply	via USB interface 2.0, USB cable 2.5 m in length	via USB interface 2.0, USB cable 2.5 m in length	via USB interface 2.0, USB cable 2.5 m in length
Camera Housing	cylindrical, oxidised metal housing	oxidised metal housing	cylindrical, oxidised metal housing
Dimensions	98 mm x 55 mm dia. approx.	110x50x50 mm ³ approx.	45 mm x 27 mm dia. approx.
Weight	160 g approx.	260 g approx.	40 g approx.
Microscope Adapter	2 adapters 30 mm dia. and 30.5 mm dia.	2 adapters 30 mm dia. and 30.5 mm dia.	2 adapters 30 mm dia. and 30.5 mm dia.
System Requirements	Windows 2000/XP(SP2)/ 2003/ Vista/2008 (32 and 64 bit)	Windows 2000/XP(SP2)/ 2003/ Vista/2008 (32 and 64 bit)	Windows 2000/XP(SP2)/ 2003/ Vista/2008 (32 and 64 bit)



9982-1005423 –
9982-1005426

9982-1005407 – 9982-1005411

9982-1003299 – 9982-1003304

9982-1005412 –
9982-1005414

9982-1003282 – 9982-1003283

Accessories for the microscopes model 100

Art. No.	Description	Specification
9982-1005423	Wide field eyepiece	WF 10x 18 mm
9982-1005424	Wide field eyepiece	WF 10x 18 mm with pointer
9982-1005425	Wide field eyepiece	WF 15x 13 mm
9982-1005426	Wide field eyepiece	WF 20x 11 mm
9982-1005407	Achromatic objective	4x / 0.10
9982-1005408	Achromatic objective	10x / 0.25
9982-1005409	Achromatic objective	40x / 0.65
9982-1005410	Achromatic objective	60x / 0.85
9982-1005411	Achromatic objective	100x / 1.25 (oil)
9982-1005412	Abbe condenser	N.A.1.25 and iris diaphragm
9982-1005413	Object holder	moveable
9982-1005414	Polarization device	Polariser with scale and analyser
9982-1005415	Spare lamp (not shown)	20 W (115 V, 50/60 Hz)
9982-1005416	Spare lamp (not shown)	20 W (230 V, 50/60 Hz)

Accessories for the polarisation microscopes and microscopes model 200, 300, 400 and 500

9982-1003282	Wide field eyepiece	WF 10x 18 mm with pointer
9982-1003283	Wide field eyepiece	WF 10x 18 mm with scale
9982-1003284	Wide field eyepiece (not shown)	WF 10x 18 mm
9982-1003285	Wide field eyepiece (not shown)	WF 15x 13 mm
9982-1003299	Achromatic objective	4x
9982-1003300	Achromatic objective	10x
9982-1003301	Achromatic objective	20x
9982-1003302	Achromatic objective	40x
9982-1003303	Achromatic objective	60x
9982-1003304	Achromatic objective	100x (oil)
9982-1003286	Semi plan achromatic objectives (see p. 82)	4x
9982-1003287	Semi plan achromatic objectives (see p. 82)	10x
9982-1003288	Semi plan achromatic objectives (see p. 82)	40x



9982-1003286 – 9982-1003289



9982-1005444 – 9982-1005447 and 9982-1005453



9982-1003290 – 9982-1003295



9982-1003297 – 9982-1003298



9982-1005448 – 9982-1005452



9982-1003296

Accessories for the polarisation microscopes and microscopes model 200, 300, 400 and 500

Art. No.	Description	Specification
9982-1003289	Semi plan achromatic objectives	100x (oil)
9982-1003290	Plan achromatic objective	4x
9982-1003291	Plan achromatic objective	10x
9982-1003292	Plan achromatic objective	20x
9982-1003293	Plan achromatic objective	40x
9982-1003294	Plan achromatic objective	60x
9982-1003295	Plan achromatic objective	100x (oil)
9982-1003296	Micrometer slide	76 mm x 26mm 1 mm / 100 div. / 0.01 mm

Accessories for the microscopes model 200 and 300

9982-1003305	Spare fluorescent lamp	5 W for 115 V mains supply
9982-1003306	Spare fluorescent lamp	5 W for 230 V mains supply

Accessories for the polarisation microscopes and microscopes model 400 and 500

9982-1003297	Dark field condenser	
9982-1003298	Dark field condenser (Oil)	
9982-1005431	Spare lamp (not shown)	Halogen, 6 V, 20 W

Accessories for the stereo microscopes 20x and 40x

9982-1005444	Wide field eyepiece, pair	WF 5x 18 mm
9982-1005445	Wide field eyepiece, pair	WF 10x 20 mm
9982-1005446	Wide field eyepiece, pair	WF 15x 13 mm
9982-1005447	Wide field eyepiece, pair	WF 20x 10 mm
9982-1005453	Eyepiece cups	Pair
9982-1005454	Spare lamp (not shown)	12 V, 10 W

Objectives for the stereo microscopes 20x

9982-1005448	Achromatic objectives	1x
9982-1005449	Achromatic objectives	2x
9982-1005450	Achromatic objectives	3x
9982-1005451	Achromatic objectives	4x
9982-1005452	Achromatic objectives	6x



9982-1003763

Box Magnifying Glass

Its size and the range of uses to which it can be put make the box magnifying glass ideal for field trips. The magnifying lens is made of plastic and magnifies by a factor of 5. The removable magnifying cover with its 30-mm diameter lens contains air holes so that small creatures can be observed for long periods.

Height 65 mm; Diameter 55 mm Ø

9982-1003763

Magnifying Glass on Stand

The magnifying glass on its stand allows you to observe small plants or insects at ease, keeping both hands free. Two pre-calibrated glass lenses are attached to the transparent acrylic base in plastic holders.



9982-1003764

9982-1003765

Magnifying Glass on Stand

10x magnification and a lens diameter of 2 cm.
5x5x4.5 cm

9982-1003769

Magnifying Glass on Stand

7x magnification and a lens diameter of 5 cm.
8x8x6.5 cm

9982-1003770



9982-1003767

Magnifying Glass with Handle

A practical magnifying glass for everyday use! An all purpose magnifying glass in a plastic frame with a handle provides assistance of professional quality to scientists and hobbyists alike with a lens 5 cm in diameter and a magnification factor of 3.5.

14x6x1.2 cm

9982-1003767



9982-1003768

Ergonomic Magnifying Glass with Handle

This magnifying glass with plastic frame offers a comfortable ergonomically designed handle and is provided with two separate lenses:

First lens Ø 75 mm: magnification: 3.5x

Second lens Ø 15 mm: magnification: 10x

Length: 13.5 cm

9982-1003768

Pick Glass, large

This version has a holder attached to make it easy to observe objects. A window of area 3.5 cm² has a cm/inch scale that allows objects to be measured in the required system. The plastic magnifying glass folds shut and has a lens of 50 mm diameter that magnifies by a factor of 3.5.

8x5.5x2.5 cm

9982-1003766

Pick Glass, small

The anodised aluminium fold-out magnifying glass has a diameter of 21 mm in spite of its small size it magnifies by a factor of 6. A window of area 1.5 cm² has a cm/inch scale that allows objects to be measured in the required system. Supplied in a leather pouch.

4x3x1.2 cm

9982-1003765

Fold-out Magnifying Glass

Pocket-sized precision optics. This is a fold-out magnifying glass with a diameter of 18 mm and a magnification factor of 10. It has a metal frame painted black and a metal case with hanging eye. Supplied in a leather pouch.

4x3.5x3.5 cm

9982-1003764

Two Way Magnifying Glasses

The built in mirror and the removable top part of this fine magnifying glasses allows observation of small animals, bugs, insects and plants from top and bottom. Size of bottom of the glass 50x50 mm. The top part can be used as an extra lens. Magnification approx. 3x.

21x14x13 cm; 2.6 kg

9982-1003790



9982-1003790

BEST SELLER



9982-1003789

9982-1003793

Bottle Magnifying Glasses with Millimetre Grid

Crystal-clear, round bottle of plastic with lid, integrated lens and millimetre grid on the bottom. Therefore it is possible to determine the size of animals and plant part quite accurately during the observation.

Bottle Magnifying Glasses with Millimetre Grid 500 ml

Lens 110 mm diameter, magnification approx. 2.5 to 3 x.

11x 8.5 cm; 0.15 kg

9982-1003793

Bottle Magnifying Glasses with Millimetre Grid 150 ml

Lens 55 mm diameter, magnification approx. 4 x.

11x8 cm; 0.15 kg

9982-1003789

MICROSCOPE SLIDES

Our microscope slides are made under rigorous scientific control. They are the product of long experience combined with the most up to date techniques. The prerequisite for excellent preparations is good material, well preserved and fixed so that the finer structures are as life-like as possible. Microtome sections are cut from this material by highly skilled and experienced staff. Cut to a thickness which will result in slides from which the maximum resolution of the structural components can be obtained. Particular attention is paid to the staining technique and in each case the selected method for a particular specimen will ensure the best possible differentiation combined with clear definition and permanency of staining. These prepared microscope slides are supplied on the best glass with finely ground edges of the size 26x76 mm (1x3") and are mailed in rigid boxes. Most sets are supplied with comprehensive explanatory brochures. All slides can be purchased either in complete sets and series or individually at a minimum quantity of 25 mixed slides. We reserve the right to make minor alterations to the advertised sets and compilations. Delivery time usually between 6 and 8 weeks, but because some micro-compounds are controlled by legal specification, delay in delivery can be experienced.

Excellent workmanship • high-contrast presentation • long life

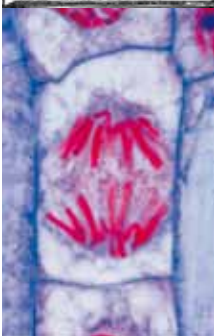
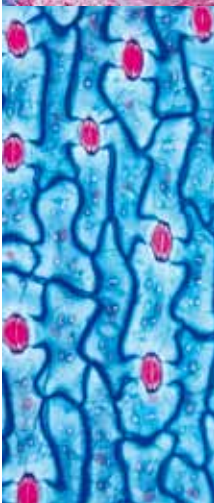
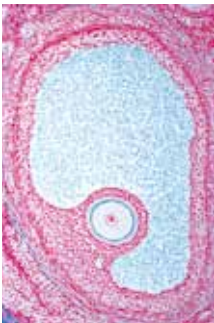

THE MULTIMEDIA PROGRAM ABCD MICROSCOPIC BIOLOGY

The multimedia system gives a concrete overview of all areas of biology that are of relevance for school classes, and which can be worked on using a microscope. The main part of the system is made up of four micropreparations – school sets A, B, C and D – which can be built onto each other. Of course, the individual series and their components can be used individually in their own right, and added to each the other. To complete the overview, we recommend using the other media. You can therefore select your favourites from our programme:

1. Microscope Slides, School Sets A, B, C and D
2. The handbook with texts and diagrams
3. An atlas with reproducible copies and colour photographs of micro-compounds
4. A CD-Rom for interactive learning

School Set A for General Biology, Elementary Set 25 microscope slides.

With depicted accompanying brochure
 1(e). Amoeba proteus, nucleus and pseudopodia 2(e). Hydra, w.m. extended specimen 3(c). Lumbricus, earthworm, typical t.s. back of clitellum 4(c). Daphnia and Cyclops, small crustaceans 5(d). Musca domestica, house fly, head and mouth parts w.m. 6(b). Musca domestica, leg with clinging pads (pulvilli) 7(c). Apis mellifica, honey bee, anterior and posterior wing 8(c). Squamous epithelium, isolated cells from human mouth 9(d). Striated muscle, l.s. showing striations 10(d). Compact bone, t.s. special stained for cells and canaliculi 11(d). Human scalp, l.s. of hair follicles 12(c). Human blood smear, red and white corpuscles 13(d). Bacteria from mouth, bacilli, cocci, spirilli, spirochaetes 14(c). Diatoms, mixed species 15(c). Spirogyra, with spiral chloroplasts 16(c). Mucor, mold, w.m. 17(c). Moss stem with leaves w.m. 18(c). Ranunculus, buttercup, typical dicot root t.s. 19(c). Zea mays, corn, monocot stem t.s. 20(c). Helianthus, sunflower, dicot stem t.s., 21(c) Syringa, lilac, leaf t.s. 22(d). Lilium, lily, anthers t.s. 23(d). Lilium, ovary t.s. showing ovules 24(c). Allium cepa, onion, w.m. of epidermis shows simple plant cells 25(d). Allium cepa, l.s. of root tips showing cell divisions (mitosis). In all stages.

9982-1004261

School Set B for General Biology, Supplementary Set 50 microscope slides.

With depicted accompanying brochure
 1(d). Paramecium 2(c). Euglena, flagellate with eyespot 3(c). Sycon, a marine sponge, t.s. 4(e). Dicrocoelium lanceolatum, sheep liver fluke, w.m. 5(c). Taenia saginata, tapeworm, proglottids t.s. 6(d). Trichinella spiralis, l.s. with encysted larvae 7(d). Ascaris, roundworm, t.s. of female 8(b). Araneus, spi-

der, leg with comb w.m. 9(d). Araneus, spider, spinneret w.m. 10(d). Apis mellifica, honey bee, mouth parts w.m. 11(b). Apis mellifica, hind leg of worker w.m. 12(e). Periplaneta, cockroach, chewing mouth parts w.m. 13(b). Trachea from insect w.m. 14(b). Spiracle from insect w.m. 15(d). Apis mellifica, sting and poison sac w.m. 16(b). Pieris, butterfly, portion of wing with scales w.m. 17(d). Asterias rubens, starfish, arm (ray). t.s. 18(e). Fibrous connective tissue 19(c). Hyaline cartilage of mammal, t.s. 20(e). Adipose tissue, stained for fat 21(d). Smooth (involuntary) muscle l.s. and t.s. 22(e). Medullated nerve fibres, osmic acid fixed material showing Ranvier's nodes 23(c). Frog blood smear, showing nucleated red corpuscles 24(d). Artery and vein of mammal, t.s. 25(d). Liver of pig, t.s. 26(c). Small intestine of cat, t.s. 27(c). Lung of cat, t.s. showing alveoli 28(c). Oscillatoria, a blue green alga 29(e). Spirogyra in scalariform conjugation 30(c). Psalliota, mushroom, t.s. of pileus with basidia and spores 31(c). Morchella, morel, t.s. of fruiting body with asci and spores 32(d). Marchantia, liverwort, antheridia l.s. 33(d). Marchantia, archegonia l.s. 34(d). Pteridium, bracken fern, rhizome t.s. 35(d). Aspidium, fern, t.s. of leaf with sori 36(e). Elodea, waterweed, stem apex l.s. with meristematic tissue 37(d). Dahlia, t.s. of tuber with inuline crystals 38(b). Allium, onion, dry scale with calcium oxalate crystals 39(d). Pyrus, pear, t.s. of fruit showing stone cells 40(c). Zea mays, corn, typical monocot root t.s. 41(c). Tilia, lime, woody dicot root t.s. 42(c). Solanum tuberosum, potato, t.s. of tuber with starch 43(c). Aristolochia, birthwort, one year stem t.s. 44(c). Aristolochia, older stem t.s. shows secondary growth 45(d). Cucurbita, pumpkin, l.s. of stem with sieve tubes, and vessels 46(d). Root tip and root hairs 47(c). Tulipa, tulip, epidermis of leaf with stomata 48(c). Iris, typical monocot leaf, t.s. 49(c). Sambucus, elderberry, stem showing lenticells, t.s. 50(e). Triticum, wheat, grain sagittal l.s. with embryo and endosperm.

9982-1004262

**School Set C for General Biology,
Supplementary Set 50 microscope slides.**

With depicted accompanying brochure

1(f). Trypanosoma gambiense, sleeping disease, blood smear 2(f). Plasmodium berghei, malaria parasite, blood smear 3(d). Radiolaria, mixed species 4(d). Foraminifera, mixed species 5(d). Obelia hydroid, w.m. of colony 6(d). Hydra, t.s. of body in different levels 7(c). Planaria, typical t.s. through the body 8(e). Apis mellifica, honey bee, head with compound eyes and brain t.s. 9(d). Apis mellifica, abdomen of worker t.s. 10(e). Ctenocephalus canis, dog flea 11(d). Dermanyssus gallinae, chicken mite 12(d). Helix pomatia, snail, hermaphrodite gland, t.s. with ova and spermatozoa 13(d). Mya arenaria, clam, gills t.s. and l.s. ciliated epithelium 14(d). Branchiostoma lanceolatum (Amphioxus), typical t.s. of body 15(c). Bird, wing and down feathers, w.m. 16(e). Salamandra larva, sections showing mitotic stages 17(f). Chicken embryo, 48 hour, t.s. with neural tube and chorda 18(d). Ovary of cat, t.s. with follicles 19(d). Testis of mouse, t.s. showing spermatogenesis 20(d). Cerebellum of cat, t.s. shows Purkinje cells 21(c). Spinal cord of cat, t.s. showing nerve cells 22(d). Kidney of cat, t.s. cortex and medulla 23(d). Retina of cat, t.s. for rods and cones 24(e). Tongue of rabbit, t.s. of papilla foliata with taste buds 25(d). Bacillus subtilis, stained for bacilli and spores 26(d). Streptococcus lactis, milk souring organisms, smear showing chains 27(e). Volvox, with daughter colonies and sexual stages, 28(d). Fucus vesiculosus, brown alga, female conceptacle with oogonia t.s. 29(d). Fucus vesiculosus, male conceptacle with antheridia t.s. 30(c). Cladophora, green alga, filaments with multinucleate cells 31(c). Claviceps purpurea, ergot, sclerotium t.s. 32(d). Puccinia graminis, wheat rust, uredinia on wheat leaf t.s. 33(d). Puccinia graminis, aecidia and pycnidia on barberry leaf t.s. 34(b). Saccharomyces, yeast, budding cells 35(d). Physcia, lichen, thallus with symbiotic algae t.s. 36(e). Fern prothallium, w.m. with sex organs 37(d). Equisetum, horse tail, strobilus with spores l.s. 38(d). Lupinus, root nodules with symbiotic bacteria t.s. 39(c). Euphorbia, spurge, stem with lactiferous ducts l.s. 40(d). Pinus, pine, three sections of wood 41(d). Tilia, lime, three sections of wood 42(d). Elodea, waterweed, aquatic stem with primitive bundle t.s. 43(d). Cucurbita, pumpkin, stem t.s. bundles and sieve plates 44(d). Fagus, beech, sun and shade leaves, two t.s. 45(c). Nerium, oleander, xerophytic leaf with sunken stomata, t.s. 46(d). Pinus, pine, male cone with pollen l.s. 47(d). Pinus, female cone with ovules l.s. 48(b). Pinus, pollen grains 49(f). Lilium, lily, t.s. of young anthers, meiotic stages of the pollen mother cells 50(d). Taraxacum, dandelion, composite flower l.s.

9982-1004263

Manual for School Sets

The handbook is made up essentially of 175 micropreparations and microslides from school sets A, B, C and D, which give a concrete overview of all areas of biology. The system includes preparations of typical microbes, of cell division, embryonic development, as well as tissues and organs from plants, animals and humans.

9982-1004049

**School Set D for General Biology,
Supplementary Set 50 microscope slides.**

With depicted accompanying brochure

1(c). Ciliated epithelium, t.s. of fallopian tube 2(d). Tendon of cow, l.s. showing white fibrous tissue 3(f). Heart muscle, human, t.s. and l.s., branched fibres with central nuclei and intercalated discs 4(c). Lymph gland of pig, t.s. showing lymphoid tissue 5(c). Esophagus of cat, t.s. with stratified squamous epithelium, muscular layers 6(d). Stomach of cat, t.s. of fundic region showing gastric glands 7(d). Large intestine (colon), t.s. stained for mucous cells 8(d). Pancreas of pig, t.s. with islets of Langerhans 9(d). Thyroid gland, sec. With glandular epithelium and colloid 10(d). Adrenal gland of cat, t.s. through cortex and medulla 11(d). Sperm of bull 12(e). Motor nerve cells, smear from spinal cord of cow 13(f). Cerebrum, human, t.s. of cortex showing pyramidal cells 14(d). Human skin from palm, l.s. 15(f). Distomum hepaticum (Fasciola), beef liver fluke, w.m. and stained 16(f). Taenia spec., tapeworm, w.m. of mature proglottids 17(e). Culex pipiens, mosquito, head mouth parts of female 18(e). Culex pipiens, head and reduced mouth parts of male 19(f). Cimex lectularius, bed bug, w.m. 20(f). Mitochondria, in thin sec. of liver or kidney 21(g). Golgi apparatus, t.s. of spinal ganglion 22(d). Chloroplasts, in leaf of Elodea or Mniium 23(c). Aleurone grains, in sec. of Ricinus endosperm 24(f). Storage, t.s. of liver or kidney, vital stained with trypan-blue to demonstrate storage 25(g). DNA in cell nuclei, demonstrated by Feulgen staining 26(g). DNA and RNA, fixed and stained to show DNA and RNA in different colours 27(f). Giant chromosomes from the salivary gland of Chironomus. Individual genes and puffs 28(h). Human chromosomes, spread in the stage of metaphase 29(f). Meiotic and mitotic stages in sec. of crayfish testis, nuclear spindles 30(f). Maturation divisions in ova of Ascaris megaloccephala, iron-hematoxylin 31(f). Cleavage stages in ova of Ascaris, iron-hematoxylin 32(d). Escherichia coli, bacteria from colon, Gram stained 33(d). Eberthella typhi, typhoid fever, Gram stained 34(e). Tuberculous lung, t.s. of diseased lung showing miliary tubercles 35(e). Coal dust lung (Anthraxosis), t.s. of human smoker's lung 36(e). Liver cirrhosis of human caused by alcohol abuse, t.s. 37(e). Arteriosclerosis, t.s. of diseased coronary artery showing sclerotic changes 38(e). Metastatic carcinoma (cancer) of human liver, t.s. 39(e). Sea-urchin development (Psammechinus), composite slide with 2, 4 and 8 cell stages 40(e). Sea-urchin development (Psammechinus), composite slide with morula, blastula and gastrula 41(f). Frog embryology (Rana), sec. of the blastula stage 42(f). Frog embryology (Rana), sag. sec. through larva in the tail bud stage 43(e). Leaf (needle), of fir (Abies), two t.s. of leaves, healthy and damaged by acid rain 44(e). Leaf of beech (Fagus), two t.s. of leaves, healthy and damaged by acid rain 45(d). Bacteria from waste-water, smear with typical forms 46(c). Nostoc, blue green alga, colonies within gelatinous sheaths 47(e). Desmids (Desmidiaceae), various species 48(c). Sphagnum, peat moss, w.m. of leaf showing chlorophyll-bearing and hyaline cells 49(c). Triticum, wheat, t.s. of stem of a gramineous plant 50(c). Salvia, sage, t.s. of a square stem with angular collenchyma

9982-1004264

**Transparency Atlas with the
Pictures of Sets A, B, C, D**

New, extended version 2002. Contents: 45 overhead transparencies sized 22x28 cm, now with 252 pictures of microscopic preparations, matching the micropreparations school sets A, B, C and D as part of the "Media System". Includes a detailed 80-page guide and 175 semi-diagrammatic illustrations. Comes in a durable plastic ring binder.

Text: Dr. Karl-Heinrich Meyer on the subject areas of: zoology, histology and anthropology, bacteria and flowerless plants, seed plants, cytology and genetics, embryology, pathogens and diseased organs, ecology and the environment.

9982-1004043

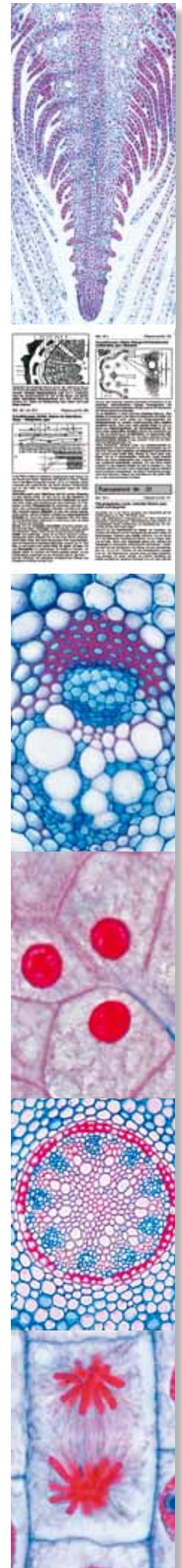

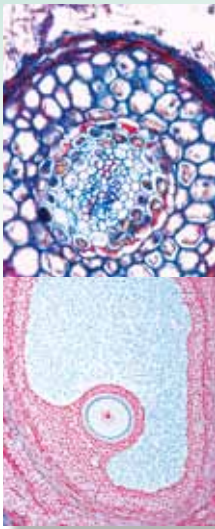

NEW INTERACTIVE EDUCATIONAL CD-ROM FOR SETS A, B, C, D

Our new amazing CD-ROM for the MULTI-MEDIA PROGRAM SCHOOL-SETS A, B, C, D of BIOLOGY comprises all necessary photomicrographs of microscopic slides, which can be observed at different magnifications, using a “microscope”. Beautiful colour drawings matching the slides, with detailed explanations.

All texts will be in five languages (English, German, Spanish, Portuguese and French), by pre-selection when starting the program.

You can read more information on our CD-ROMs on page 166.

MICROSCOPIC BIOLOGY – Set A

Photomicrographs, diagrams, explanations, test program and teaching material. Comprising about 240 pictures and 1,175 texts.

9982-1004269

MICROSCOPIC BIOLOGY – Set B

Photomicrographs, diagrams, explanations, test program and teaching material. Comprising about 570 pictures and 2,835 texts.

9982-1004270

MICROSCOPIC BIOLOGY – Set C

Photomicrographs, diagrams, explanations, test program and teaching material. Comprising about 400 pictures and 1,960 texts.

9982-1004271

MICROSCOPIC BIOLOGY – Set D

Photomicrographs, diagrams, explanations, test program and teaching material. Comprising about 440 pictures and 2,125 texts.

9982-1004272

Microscope Slide Sets

The Microscope Slide Sets provide microscope slide collections for the most popular areas. Allowing you to place important topics “under the microscope”.

SERIES FOR SECONDARY SCHOOLS

Series I. Cells, Tissues and Organs

13 Microscope Slides

1(d). Simple animal cells in sec. of salamander liver 2(d). Mitosis, l.s. from Allium root tips 3(c). Ranunculus, buttercup, t.s. of a typical dicot root 4(e). Monocot and dicot stems, two t.s. for comparison 5(c). Syringa, lilac, t.s. of a typical mesophytic dicot leaf 6(c). Columnar epithelium, t.s of blind gut from rabbit 7(e). Bone and hyaline cartilage, t.s. 8(d). Striated muscles of mammal, l.s. 9(d). Smooth muscles of mammal, l.s. and t.s. 10(c). Lung of cat, t.s. 11(c). Human blood smear 12(d). Human body skin, l.s. 13(f). Young mouse, sag. s. of entire specimen for all structures.

9982-1004225

Series II. Metabolism

15 Microscope Slides

1(e). Hydra, fresh water polyp, t.s. with ectoderm and endoderm 2(d). Carabus, ground beetle, gizzard 3(c). Salivary gland of cat, t.s. 4(c). Oesophagus of cat, t.s. 5(d). Fundic stomach of cat, t.s. 6(c). Small intestine of cat, t.s. routine stained 7(f). Small intestine, t.s. blood vessels injected 8(d). Appendix of human, t.s. 9(c). Large intestine of cat, t.s. 10(c). Liver of pig, t.s. 11(f). Malpighian tubules of insect, t.s. 12(c). Primordial kidney (mesonephros) of frog, t.s. 13(d). Hind-kidney (metanephros) of rabbit, t.s. 14(d). Kidney of mouse with pelvis, l.s. 15(f). Kidney of mouse, t.s. injected to show storage.

9982-1004226

Series IV. Hormone Organs and Hormonal Function

7 Microscope Slides

1(d). Ovary of cat, with follicles and corpus luteum t.s. 2(d). Testis of mouse, t.s. showing Leydig’s cells 3(d). Adrenal (suprarenal) gland of cat, t.s. 4(d). Pancreas of cat, t.s. with islets of Langerhans, 5(f). Thyroid gland, normal function t.s. 6(f). Thyroid gland, over-activity of the gland t.s. 7(f). Hypophysis (pituitary body) sagittal l.s.

9982-1004228

Series III. Organs of Sense

16 Microscope Slides

1(e). Paramecium, silvered to show the neuroformative system 2(d). Lumbricus, earthworm, t.s. with ventral nerve cord 3(e). Insect brain, frontal l.s. 4(e). Planaria, sec. through ocelli 5(f). Haliotis, marine snail, pinhole camera eye l.s. 6(e). Helix, snail, eye l.s. 7(e). Alloteuthis, cuttlefish, camera eye l.s. 8(e). Compound eye of an insect, l.s. 9(e). Young rat, head with eyes t.s. 10(d). Retina of cat, t.s. showing rods and cones 11(e). Internal ear (cochlea) from guinea pig, l.s. 12(e). Taste buds from tongue of rabbit, t.s. 13(e). Peripheral nerve fibres, osmic acid material showing Ranvier’s nodes 14(c). Spinal cord of cat t.s. with large motor nerve cells 15(c). Cerebellum of cat, t.s. routine stained 16(f). Cerebrum of cat, t.s. silvered to show the pyramid cells.

9982-1004227

Series V. Genetics, Reproduction and Embryology

19 Microscope Slides

1(g). DNA and RNA stained in different colours, l.s. onion root tips 2(e). Lilium, young anthers, meiosis, early prophase stage, t.s. 3(e). Lilium, young anthers, diplotene stage, t.s. 4(d). Lilium, ovary with embryosac t.s. 5(d). Capsella bursa pastoris, l.s. of embryos 6(h). Human chromosomes, spread in the metaphase stage, w.m. 7(g). Lamp brush chromosomes 8(e). Hydra with testis t.s. 9(e). Hydra with ovaries t.s. 10(f). Tapeworm (Taenia), mature proglottid, w.m. 11(f). Ascaris, sec. of uteri showing maturation of ova 12(e). Cockchafer (Melolontha), ovaries t.s. 13(d). Frog (Rana), testis t.s. showing spermatogenesis 14(f). Frog embryology: four cell stage t.s. 15(f). Frog: morula stage l.s. 16(f). Frog: neurula stage t.s. 17(f). Chicken (Gallus) embryology: 24 hour t.s. 18(f). Chicken embryology: 72 hour t.s. 19(d). Mouse, uterus containing embryo t.s.

9982-1004229

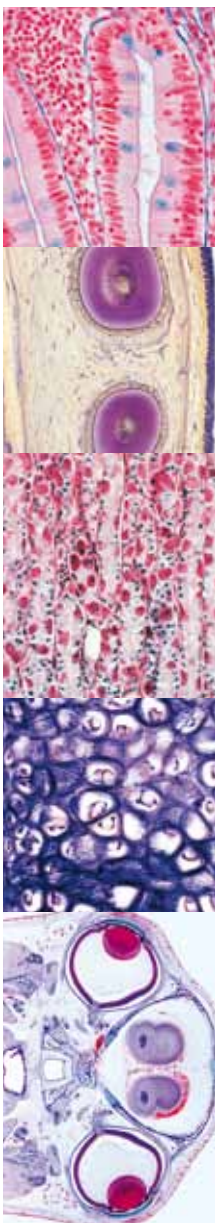

HISTOLOGY – Detail Sets

Histology of Vertebrata Excluding Mammalia

Fishes, Amphibians, Reptiles, Birds – 25 Microscope Slides
 1(c). Cyprinus, carp, liver t.s. 2(c). Cyprinus, testis t.s. showing spermatozoa 3(c). Cyprinus, small intestine t.s. 4(c). Cyprinus, kidney t.s. 5(c). Cyprinus, gills t.s. 6(c). Cyprinus, skin t.s. 7(f). Fish scales, cycloid, ctenoid, and placoid scales w.m. 8(c). Salamandra, skin with poison glands t.s. 9(d). Salamandra, t.s. through thorax and forelegs of larva 10(c). Rana, frog, lung t.s., a simple bag-like lung 11(c). Rana, blood smear, with nucleated corpuscles 12(c). Rana, stomach t.s. 13(c). Rana, large intestine t.s., with goblet cells 14(c). Rana, liver t.s. showing bile ducts 15(c). Rana, kidney t.s. 16(c). Rana, testis t.s. to show spermatogenesis 17(c). Rana, skin t.s. showing glands 18(d). Lacerta, lizard, skin with scales, sagittal l.s. 19(c). Gallus, chicken, blood smear, with nucleate red corpuscles 20(c). Gallus, lung t.s. 21(c). Gallus, glandular stomach t.s. 22(d). Gallus, ovary with developing eggs t.s. 23(d). Gallus, skin with developing feathers t.s. or l.s. 24(c). Gallus, unfeathered skin of foot t.s. 25(c). Gallus, wing and down feathers w.m.

9982-1004230

Histology of Mammalia, Supplementary Set

50 Microscope Slides
 1(c). Columnar epithelium of mammal 2(c). Ciliated epithelium of mammal 3(d). White fibrous tissue, l.s. of tendon of cow 4(d). Mucous tissue, t.s. of navel string 5(d). Elastic cartilage, sec. stained for elastic fibres 6(d). Bone development, l.s. of foetal finger 7(d). Striated muscle of cat, t.s. 8(c). Heart muscle of cat, l.s. and t.s. 9(d). Red bone marrow of cow, sec. or smear 10(f). Heart of mouse, sagittal l.s. 11(d). Trachea of rabbit, t.s. 12(c). Spleen of cat, t.s. 13(c). Lymph gland of cat or rabbit, t.s. 14(d). Adrenal (suprarenal) gland of rabbit, t.s. 15(e). Epiphysis (pineal body) of cow or pig, t.s. 16(e). Hypophysis (pituitary body) of cow or pig, l.s. 17(d). Thyroid gland of cow, t.s. 18(d). Thymus gland of cow, t.s. with Hassall bodies 19(d). Parotid gland of cat, t.s. 20(d). Tooth, t.s. through root or crown 21(c). Oesophagus of rabbit, t.s. 22(c). Vermiform appendix of rabbit, t.s. 23(c). Large intestine (colon) of rabbit, t.s. 24(c). Gall bladder of rabbit, t.s. 25(f). Kidney t.s., vital stained with trypan blue showing storage 26(c). Ureter of rabbit, t.s. 27(c). Urinary bladder of rabbit, t.s. 28(d). Ovary with corpus luteum t.s. 29(c). Fallopian tube of pig, t.s. 30(c). Uterus of rabbit, t.s. 31(c). Placenta of rabbit, t.s. 32(d). Uterus of rat, containing embryo t.s. 33(d). Vagina of rabbit, t.s. 34(c). Epididymis of rabbit, t.s. 35(d). Sperm smear of bull 36(d). Penis of rabbit, t.s. 37(d). Prostate gland of pig, t.s. 38(e). Brain of mouse, entire organ l.s. 39(f). Cerebellum, t.s. silver stained for Purkinje cells 40(e). Sympathetic ganglion, t.s. multipolar nerve cells 41(c). Peripheral nerve of cat or rabbit, l.s. 42(e). Eye of cat, anterior part with cornea t.s. 43(e). Eye of cat, posterior part with retina t.s. 44(e). Cochlea (internal ear) of Guinea pig, l.s. shows organ of Corti 45(d). Olfactory region of dog or rabbit, t.s. 46(e). Taste buds in tongue of rabbit (Papilla foliata), t.s. 47(d). Skin of human palm, t.s. 48(d). Scalp, human, t.s. of hair follicles 49(d). Nail development of embryo, sagittal l.s. 50(c). Mammary gland of cow, t.s.

9982-1004232

Histology of Mammalia, Elementary Set

25 Microscope Slides
 1(c). Squamous epithelium, isolated cells 2(e). Fibrous connective tissue, w.m. from pig mesentery 3(e). Adipose tissue of mammal, fat stained 4(c). Hyaline cartilage of calf, t.s. 5(e). Compact bone of cow, t.s. 6(d). Striated muscles of cat, l.s. 7(d). Smooth muscles of cat, t.s. and l.s. 8(c). Blood smear, human 9(d). Artery of cat or rabbit, t.s. 10(d). Vein of cat or rabbit, t.s. 11(c). Lung of cat, t.s. 12(c). Pancreas of pig with islets of Langerhans t.s. 13(c). Tongue of cat, t.s. with cornified

papillae 14(d). Stomach of cat, fundic region t.s. 15(c). Small intestine of cat or rabbit, t.s. 16(d). Liver of pig, t.s. 17(d). Kidney of cat, t.s. 18(d). Ovary of rabbit, t.s., developing follicles 19(d). Testis of mouse, t.s., spermatogenesis 20(d). Cerebrum of cat, t.s. 21(d). Cerebellum of cat, t.s. 22(c). Spinal cord of cat, t.s. 23(e). Nerve fibres isolated, Ranvier's nodes 24(e). Motor nerve cells, smear from spinal cord 25(d). Scalp, human, l.s. of hair follicles

9982-1004231

Normal Human Histology, Basic Set

40 Microscope Slides
 When compiling the series only top quality, histologically fixed material was used for the preparation of the slides. The cutting thickness of the microtome sections is normally 6 – 8 mm. The use of special staining methods guarantees a clear, multicoloured representation of all tissue structures. This slide series occupies a special position due both to the quality of the original material because of the carefulness of the preparation.
 1(c). Squamous epithelium, human, isolated cells 2(f). Areolar connective tissue, human w.m. 3(f). Hyaline cartilage, human t.s. 4(f). Compact bone, human t.s. 5(f). Striated muscle, human l.s. 6(f). Heart muscle, human l.s. and t.s. 7(f). Artery, human t.s. 8(f). Vein, human t.s. 9(f). Lung, human t.s. 10(c). Blood smear, human 11(f). Spleen, human t.s. 12(f). Thyroid gland, human t.s. 13(f). Thymus gland from human child t.s. 14(f). Tongue, human t.s. 15(f). Tooth, human l.s. 16(f). Parotid, human gland t.s. 17(f). Oesophagus, human t.s. 18(f). Stomach, human, fundic region t.s. 19(f). Duodenum, human t.s. (small intestine) 20(f). Colon, human t.s. (large intestine) 21(f). Pancreas, human t.s. 22(f). Liver, human t.s. 23(e). Vermiform appendix, human t.s. 24(f). Kidney, human t.s. 25(f). Adrenal (suprarenal) gland, human t.s. 26(f). Ovary, human t.s. 27(f). Uterus, human t.s. 28(f). Placenta, human t.s. 29(f). Testis, human t.s. 30(f). Epididymis, human t.s. 31(f). Cerebrum, human t.s. 32(f). Cerebellum, human t.s. 33(f). Spinal cord, human t.s. 34(f). Sympathetic ganglion, human t.s. 35(e). Skin of palm, human t.s. 36(e). Scalp, human, l.s. of hair follicles 37(e). Scalp, human, t.s. of hair follicles 38(f). Retina, human t.s. 39(e). Finger tip from foetus with nail development l.s.

9982-1004233

Normal Human Histology, Large Set, Part I

50 Microscope Slides
 1(c). Isolated squamous epithelium, human 2(e). Connective tissue, human, sec. 3(e). Columnar epithelium, human gall bladder, t.s. 4(e). Ciliated epithelium, human trachea, t.s. 5(e). Smooth muscles, human, l.s. and t.s. 6(e). Striated muscles, human, l.s. 7(e). Heart muscles, human, l.s. and t.s. 8(e). Hyaline cartilage, human, sec. 9(e). Elastic cartilage of epiglottis, human, t.s. 10(e). Bone, compact substance, human, t.s. 11(e). White fibrous tissue (tendon), human, l.s. 12(e). Red bone marrow, human, t.s. 13(d). Scalp, human, l.s. of hair follicles 14(e). Artery, human, t.s. 15(e). Vein, human, t.s. 16(c). Blood smear, human, Giemsa stain 17(e). Lung, human, t.s. 18(f). Larynx of human foetus, t.s. 19(e). Lymph gland, human, t.s. 20(e). Thyroid gland, human, t.s. 21(f). Pituitary gland, human, t.s. 22(e). Spleen, human, t.s. 23(e). Tongue, human, t.s. 24(e). Oesophagus, human, t.s. 25(e). Sublingual gland, human, t.s. 26(e). Stomach, pyloric region, human, t.s. 27(e). Pancreas, human, t.s. 28(e). Small intestine, human, t.s. 29(e). Large intestine, human, t.s. 30(e). Liver, human, t.s. 31(e). Kidney, human, t.s. 32(f). Adrenal gland, human, t.s. 33(e). Ureter, human, t.s. 34(e). Urinary bladder, human, t.s. 35(f). Ovary, human, t.s. 36(e). Uterus, human, t.s. 37(e). Uterine tube, human, t.s. 38(e). Placenta, human, t.s. 39(e). Umbilical cord, human, t.s. 40(e). Mammary gland, human, sec. 41(f). Testis, human, t.s. 42(e). Epididymis, human, t.s. 43(f). Olfactory epithelium, human, t.s. 44(f). Retina, human, t.s. 45(g). Internal ear, human foetal, t.s. 46(f). Touch corpuscles in human skin, t.s. 47(e). Nerve, human, l.s. 48(e). Spinal cord, human, t.s. 49(e). Cerebellum, human, t.s. 50(e). Cerebrum, cortex, human, t.s.

9982-1004234

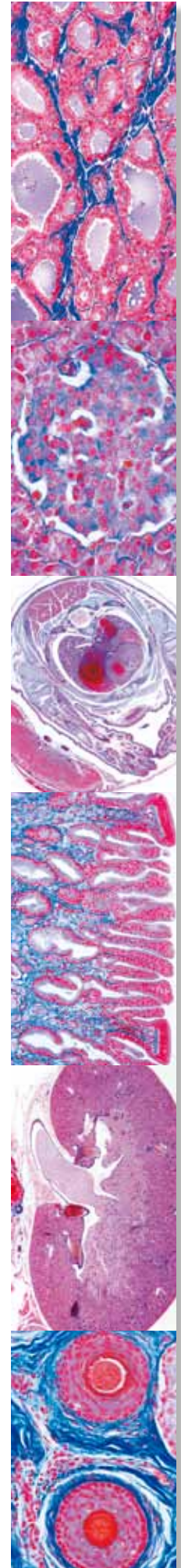

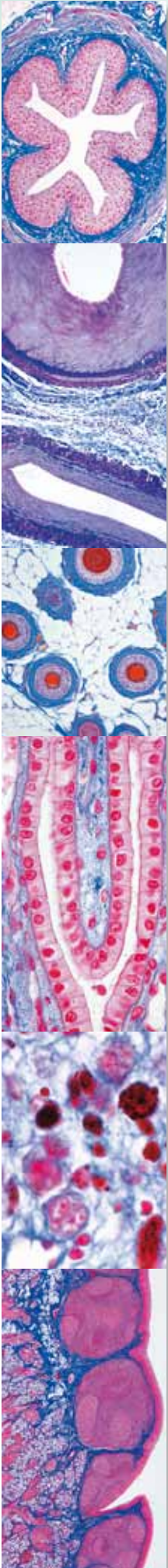

Normal Human Histology, Large Set, Part II.

50 Microscope Slides

1(e). Soft palate, human t.s. 2(e). Adipose tissue, human, sec. stained for fat 3(f). White fibrous cartilage, human intervertebral disc, sec. 4(e). Striated (skeletal) muscle, human t.s. 5(e). Spongy (cancellous) bone, human t.s. 6(e). Bone development, vertical l.s. of foetal skull-cap 7(e). Bone development, l.s. of foetal finger 8(e). Joint of human foetus, l.s. 9(e). Tooth, human, t.s. of crown 10(f). Tooth, human, complete l.s. 11(f). Tooth development from human foetus, l.s. 12(e). Aorta, human, t.s. routine stained 13(e). Trachea from human foetus t.s. 14(f). Thymus from human child, t.s. 15(f). Parathyroid gland (Gl. parathyreoidea), human t.s. 16(e). Tonsil (Tonsilla palatina), human t.s. 17(e). Parotid gland (Gl. parotis), human t.s. 18(e). Submaxillary gland (Gl. submandibularis), human t.s. 19(e). Stomach, fundic region, human t.s. 20(e). Stomach, cardiac region, human t.s. 21(e). Jejunum, human t.s. 22(f). Small intestine (Duodenum) t.s. colouring of goblet cells, PAS-HE 23(e). Vermiform appendix, human t.s. 24(e). Rectum, human t.s. 25(e). Gall bladder, human t.s. 26(e). Liver of human foetus sec., developing blood cells 27(e). Urethra, human, t.s. 28(e). Seminal vesicle (Gl. vesiculosa), human t.s. 29(e). Spermatic cord (Ductus deferens), human t.s. 30(e). Prostate, human, t.s. 31(e). Sperm smear, human 32(f). Corpus luteum in t.s. of human ovary 33(e). Vagina, human t.s. 34(g). Cerebral cortex, human, t.s. silvered (Golgi or Palmgren) 35(g). Cerebral cortex, human, t.s. stained for neuroglial cells after Held 36(g). Cerebellum, human, t.s. silvered (Golgi or Palmgren) 37(f). Thalamus, human, stained after Klüver – Barrera 38(f). Medulla oblongata, human, t.s. routine stained 39(g). Spinal cord, human, t.s. silvered (Golgi or Palmgren) 40(f). Sympathetic ganglion, human t.s. routine stained 41(e). Peripheral nerve, human t.s. 42(e). Optic nerve, human t.s. 43(e). Cornea from eye, human t.s. 44(e). Eyelid, human, t.s. 45(e). Skin from finger tip, human, vertical l.s. 46(d). Scalp, human, horizontal l.s. shows t.s. of hair follicles, 47(e). Nail development, sagittal l.s. finger tip of human foetus 48(h). Human chromosomes in smear from culture of blood, male 49(i). Human chromosomes in smear from culture of blood, female 50(f). Barr bodies (human sex chromatin) in smear from female squamous epithelium.

9982-1004235

Human Pathology

50 Microscope Slides

1(e). Parenchymatous and fatty degeneration of liver 2(e). Hemosiderosis of liver 3(e). Glycogenosis of liver 4(e). Pigmentary cirrhosis of liver 5(e). Necrotic oesophagitis 6(e). Foreign body granuloma with hemosiderin and giant cells 7(e). Tonsillitis 8(e). Liver cirrhosis Injury of circulatory organs and blood-forming organs 9(e). Adiposis of heart 10(e). Cardiac callosity 11(e). Myocarditis chronica acute recidivans 12(e). Organized venous thrombosis of muscle 13(e). Infarct of spleen 14(e). Chronic myeloid leukemia of spleen 15(g). Malarial melanemia of spleen Pathologic alterations of lung and liver, tuberculosis, pneumonia 16(e). Anthracosis of lung 17(e). Hemorrhagic infarct of lung 18(e). Influenzal pneumonia 19(e). Croupous pneumonia 20(e). Chronic pneumonia 21(e). Necrotic (cheesy) pneumonia 22(e). Miliary tuberculosis of lung 23(e). Chronic tuberculous pulmonary cavity with bacteria 24(e). Icterus hepatis Reaction of kidney after arteriosclerosis, disturbance of metabolism, and inflammation; colitis 25(e). Glomerular atrophy of kidney 26(e). Amyloid degeneration of kidney 27(e). Acute haemorrhagic nephritis 28(e). Chronic glomerulonephritis 29(e). Septic embolic nephritis 30(e). Colitis dysenterica Shiga-Kruse Specific inflammations after infection with syphilis spirochaetes 31(g). Congenital syphilis of liver, spirochaetes silvered after Levaditi 32(f). Congenital syphilis of liver (feuerstein liver), routine stained 33(f). Gumma of testicle Progressive alteration of injured tissues and organs (Hypertrophy and hyperplasia) 34(e). Atheroma of head 35(e). Struma colloides 36(f). Undescended testicle showing

hyperplasia of Leydig's cells 37(e). Hypertrophy of prostate Benignant and malignant tumors 38(f). Giant cell sarcoma of maxilla 39(e). Chondroma of pubic bone 40(e). Myoma of uterus 41(e). Fibroadenoma of breast 42(e). Fibroepithelial mixed tumor of parotid gland 43(e). Melanosarcoma of skin 44(e). Spindle cell sarcoma 45(e). Carcinoma cervicis uteri 46(e). Sarcoma of testicle 47(e). Cystadenoma papilliferum of ovary 48(e). Gelatinous carcinoma of rectum 49(e). Lymphosarcoma mediastini 50(e). Metastatic carcinoma of liver.

9982-1004236

HISTOLOGY – COMPREHENSIVE SET

Tissues

15 Microscope Slides

1(c). Squamous epithelium, scrapings from human mouth, w.m. 2(e). Columnar epithelium, human gall bladder, t.s. 3(e). Ciliated epithelium, human trachea, t.s. 4(d). Skin, human, from general body surface showing sweat glands 5(d). Human scalp, l.s. of hair 6(d). Developing of nail, human embryo, l.s. 7(e). Hyaline cartilage, human, t.s. 8(d). Elastic cartilage, ear of pig, t.s. 9(e). Developing cartilaginous bone, joint of human foetus, l.s. 10(e). Compact bone, c.s. and l.s. 11(f). Striated muscle, human, l.s., staining of striations 12(e). Striated muscle, human, t.s. 13(e). Smooth muscle, human, t.s. and l.s. 14(e). White fibrous tissue, human tendon, l.s. 15(e). Adipose tissue, human, t.s.

9982-1004237

Human Scalp and Hair

12 preparations.

For details, please go to www.3bscientific.com.

9982-1004268

Respiratory and Circulatory System

10 Microscope Slides

1(d). Trachea, cat, t.s. 2(e). Lung, human t.s. 3(c). Blood, human, Wright stained smear 4(c). Artery, human, t.s., elastica stained 5(e). Vein, human, t.s., elastica stained 6(e). Artery and vein, human, t.s., elastica stained 7(e). Aorta, human, t.s. 8(e). Heart muscle, human t.s. and l.s. intercalated discs 9(e). Lymph gland, human, t.s. 10(e). Red bone marrow, human rib, t.s. Giemsa stained.

9982-1004238

Digestive System

11 preparations with accompanying guide.

For details, please go to www.3bscientific.com.

9982-1004239

Urinary System

10 preparations with accompanying guide.

For details, please go to www.3bscientific.com.

9982-1004240

Genital System

14 preparations with accompanying guide.

For details, please go to www.3bscientific.com.

9982-1004241

Endocrine System

6 preparations with accompanying guide.

For details, please go to www.3bscientific.com.

9982-1004242

Sensory Organs

10 preparations with accompanying guide.
For details, please go to www.3bscientific.com.

9982-1004243

Nervous System

11 Microscope Slides

1(e). Cerebrum, human, cortex, t.s. 2(e). Cerebellum, human, t.s. 3(f). Cerebellum, human, t.s., Weigert stained 4(e). Spinal cord, human, t.s. for general structure 5(e). Nerve, human, l.s. 6(e). Nerve, human, t.s. 7(f). Spinal cord, cat, t.s., Klüver-Barrera stained 8(e). Spinal cord, cow, t.s., Nissl stained 9(f). Cerebrum, cat, t.s., Golgi stained 10(e). Brain, rat, median l.s. 11(d). Vertebra with spinal cord, rat, t.s.

9982-1004244

ZOOLOGY – DETAIL SETS

Invertebrata, Elementary Set

25 Microscope Slides

The most important representatives of Protozoa, Sponges, Coelenterata, Vermes, Arthropoda, Insecta, Mollusca, Echinodermata, Acrania. 1(e). Amoeba proteus, w.m. 2(c). Euglena, a common flagellate with eye spot 3(d). Paramecium, a common ciliate 4(c). Sycon, marine sponge, t.s. of body 5(e). Hydra, extended specimen w.m. 6(e). Dicrocoelium lanceolatum, sheep liver fluke, w.m. 7(c). Planaria, t.s. of body 8(c). Taenia saginata, tapeworm, proglottids in different stages t.s. 9(d). Trichinella spiralis, l.s. of muscle with encysted larvae 10(c). Lumbricus, earthworm, t.s. of body in region of typhlosole 11(c). Daphnia, water flea w.m. 12(c). Cyclops, copepod w.m. 13(b). Spider, leg with comb w.m. 14(c). Spider, spinneret w.m. 15(c). Musca domestica, house fly, head and mouth parts w.m. 16(e). Periplaneta, cockroach, biting mouth parts w.m. 17(e). Apis mellifica, honey bee, mouth parts of worker w.m. 18(b). Musca domestica, house fly, leg with pulvilli w.m. 19(b). Apis mellifica, wings w.m. 20(b). Trachea from insect w.m. 21(b). Spiracle from insect w.m. 22(d). Drosophila, fruit fly, sagittal l.s. of adult specimen 23(d). Snail, radula w.m. or section 24(d). Snail, t.s. through body 25(d). Asterias, starfish, t.s. of arm (ray).

9982-1004245

Invertebrata, Supplementary Set

50 Microscope Slides

1(d). Radiolaria, mixed species 2(d). Foraminifera, mixed species 3(c). Ceratium, dinoflagellates 4(f). Trypanosoma, causing sleeping disease, blood smear 5(f). Plasmodium, malaria parasite, blood smear 6(d). Eimeria stiedae, in t.s. of rabbit liver with parasites 7(b). Spongilla, fresh water sponge, gemmulae (winter bodies) 8(c). Hydra, t.s. of body 9(d). Obelia hydroid, w.m. of colony 10(e). Obelia medusa, jellyfish. w.m. 11(d). Actinia, sea anemone, t.s. young specimen 12(c). Fasciola hepatica, beef liver fluke, t.s. of body 13(c). Fasciola, ova w.m. 4(d). Ascaris, roundworm, t.s. of female in region of gonads 15(d). Ascaris, t.s. of male in region of gonads 16(e). Lumbricus, earthworm, l.s. of anterior region with gonads 17(c). Lumbricus, sperm smear 18(d). Hirudo medicinalis, leech, t.s. of body 19(d). Sagitta, arrow worm, entire specimen w.m. 20(c). Astacus, crayfish, gills t.s. 21(c). Astacus, liver t.s. 22(e). Astacus, testis t.s. showing spermatogenesis 23(d). Astacus, ovary t.s. showing developing ova 24(c). Astacus, intestine t.s. 25(d). Spider, abdomen with internal organs l.s. 26(d). Dermanyssus gallinae, chicken mite w.m. 27(e). Pieris, butterfly, head and mouth parts w.m. 28(e). Vespa, wasp, biting mouth parts w.m. 29(f). Carabus, ground beetle, biting mouth parts w.m. 30(d). Culex pipiens, mosquito, piercing-sucking mouth parts w.m. 31(b). Melolontha, cockchafer, antenna w.m. 32(b). Apis mellifica, honey bee, anterior leg with eye brush w.m. 33(b). Apis mellifica, posterior leg with pollen basket w.m. 34(b). Pieris, butterfly, portion of wing with scales w.m. 35(b). Apis mellifica, cornea from eye w.m. 36(d). Apis mellifica, sting

with poison sac w.m. 37(d). Culex pipiens, mosquito, t.s. of abdomen 38(e). Apis mellifica, honey bee, head with compound eyes t.s. 39(d). Apis mellifica, abdomen of worker t.s. 40(e). Ctenocephalus, dog flea, w.m. of adult 41(c). Chironomus, gnat, larva w.m. 42(d). Bombyx mori, silkworm, t.s. of caterpillar, spinning glands 43(d). Helix, snail, hermaphrodite gland (ovotestis) t.s. 44(c). Helix, snail, liver t.s. 45(e). Helix, snail, eye l.s. 46(d). Mya arenaria, clam, gills t.s. and l.s. 47(e). Asterias, starfish, horizontal section of young specimen 48(d). Psammechinus, sea urchin, pluteus larva w.m. 49(d). Branchiostoma lanceolatum (Amphioxus), t.s. of body with testis 50(d). Branchiostoma, t.s. of body with ovaries.

9982-1004246

ZOOLOGY – COMPREHENSIVE SETS

Protozoa

10 Microscope Slides

1(e). Amoeba proteus, Rhizopoda, w.m. 2(d). Radiolaria, mixed species, fossil 3(d). Foraminifera from Mediterranean sea, mixed species, recent 4(c). Euglena viridis, a green flagellate, w.m. 5(c). Ceratium hirundinella, fresh-water dinoflagellate w.m. 6(f). Trypanosoma gambiense, causes African sleeping sickness, blood smear 7(f). Plasmodium, causes human malaria, blood smear 8(d). Eimeria stiedae, causing coccidiosis, t.s. of infected liver 9(d). Paramecium, a common ciliate, nuclei stained 10(e). Vorticella, a colonial ciliate.

9982-1003960

Coelenterata and Porifera

10 Microscope Slides

1(e). Sycon, a small marine sponge of the sycon type, l.s. and t.s. on one slide 2(d). Spongilla, fresh-water sponge, t.s. 3(d). Euspongia, commercial sponge, t.s. 4(c). Sponge spicules of different kinds, mixed w.m. 5(e). Hydra, fresh water polyp, extended and w.m. 6(d). Hydra, t.s. in different levels 7(d). Laomedea, w.m. of colony, vegetative and reproductive polyps 8(e). Obelia, w.m. of medusa 9(e). Aurelia, jellyfish, w.m. of ephyra 10(e). Actinia, sea anemone, l.s. and t.s.

9982-1003961

Vermes (Helminthes)

20 Microscope Slides

1(f). Planaria, (Turbellaria) w.m. 2(c). Planaria, t.s. for general structure 3(f). Fasciola hepatica, large liver fluke, w.m. 4(c). Fasciola, t.s. of middle region of body 5(f). Taenia sp., tapeworm, proglottids, w.m. 6(c). Taenia sp., mature proglottids, t.s. 7(g). Taenia or Moniezia, tapeworm, scolex and proglottides, w.m. 8(f). Echinococcus multilocularis, infected liver, sec. 9(f). Enterobius vermicularis, pinworm, w.m. 10(d). Trichinella spiralis, encysted larvae in muscles, l.s. 11(e). Ascaris, roundworm, adult male and female, t.s. 12(d). Nemertine, marine species, t.s. of body 13(d). Nereis, sea-worm, t.s. 14(d). Tubifex, oligochaete, w.m. 15(d). Hirudo medicinalis, leech, t.s. 16(e). Lumbricus, earthworm, anterior end, l.s. 17(c). Lumbricus, region of seminal vesicles, t.s. 18(d). Lumbricus, t.s. with stomach 19(c). Lumbricus, t.s. with intestine and nephridia 20(d). Lumbricus, t.s. with setae.

9982-1003962

Crustacea

10 preparations with accompanying guide.

For details, please go to www.3bscientific.com.

9982-1003963

Arachnoidea and Myriapoda

12 preparations with accompanying guide.

For details, please go to www.3bscientific.com.

9982-1003964

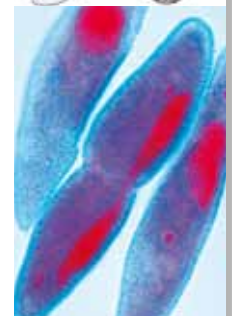

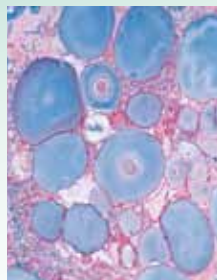

The Honey Bee (*Apis mellifica*)

18 preparations.

For details, please go to www.3bscientific.com.

9982-1004265

Insect (Insecta)

40 Microscope Slides

1(d). *Musca domestica*, housefly, leaking-sucking mouth parts w.m. 2(e). *Pieris*, butterfly, sucking mouth parts w.m. 3(f). *Carabus*, ground beetle, biting mouth parts (carnivore) w.m. 4(f). *Melolontha*, cockchafer, chewing mouth parts (herbivore) w.m. 5(e). *Pyrrhocoris*, bug, piercing sucking mouth parts w.m. 6(d). *Bombyx mori*, silkworm moth, chewing mouth parts 7(e). *Apis mellifica*, honey bee, leaking sucking mouth parts of worker w.m. 8(e). *Vespa vulgaris*, wasp, biting mouth parts of carnivore w.m. 9(f). *Periplaneta* or *Blatta*, cockroach, chewing biting mouth parts w.m. 10(e). *Culex pipiens*, mosquito, piercing sucking mouth parts w.m. 11(b). *Melolontha*, cockchafer, antenna with sense organs w.m. 12(b). *Bombyx mori*, silkworm moth, feathered antenna w.m. 13(b). *Pieris*, butterfly, clubbed antenna w.m. 14(b). *Apis mellifica*, anterior leg with eye brush w.m. 15(b). *Apis mellifica*, posterior leg with pollen basket w.m. 16(b). *Musca domestica*, house fly, leg with pulvilli w.m. 17(c). *Apis mellifica*, wings w.m. 18(b). *Pieris*, butterfly, portion of wings with scales w.m. 19(b). Trachea from insect w.m. 20(b). Spiracle from insect w.m. 21(b). Cornea isolated from insect eye w.m. 22(d). *Apis mellifica*, honey bee, sting and poison sac w.m. 23(e). *Apis mellifica*, head with compound eyes and brain t.s. 24(d). *Bombyx mori*, silkworm, t.s. showing silk spinning glands 25(d). *Carausius*, walking stick, abdomen t.s. 26(e). *Melolontha*, cockchafer, ovaries of insect, sec. shows developing ova 27(f). Grasshopper, testis t.s. to show spermatogenesis and cell division 28(f). *Drosophila*, fruit fly, sagittal l.s. for general insect anatomy 29(d). *Drosophila*, fruit fly, w.m. of adult 30(e). *Ctenocephalus canis*, dog flea, w.m. of adult 31(d). *Caenis*, May fly, larva with tracheal gills w.m. 32(f). *Pediculus humanus*, human louse, adult w.m. 33(d). Thysanoptera, thrips, adult w.m. 34(c). Aphidae, plant lice adults and larvae w.m. 35(f). *Cimex lectularius*, bed bug, w.m. of adult 36(d). *Culex pipiens*, mosquito, w.m. of larva 37(d). *Culex pipiens*, mosquito, w.m. of pupa 38(f). *Culex pipiens*, mosquito, w.m. of adult female 39(f). *Culex pipiens*, mosquito, w.m. of adult male 40(d). *Chironomus*, gnat, w.m. of larva.

9982-1003965

Mollusca

15 preparations with accompanying guide.

For details, please go to www.3bscientific.com.

9982-1003966

Echinodermata, Bryozoa and Brachiopoda

10 preparations with accompanying guide.

For details, please go to www.3bscientific.com.

9982-1003967

Cephalochordata (Acrania)

10 preparations with accompanying guide.

For details, please go to www.3bscientific.com.

9982-1003968

The Paramecium (*Caudatum*)

8 preparations with accompanying guide.

For details, please go to www.3bscientific.com.

9982-1004247

PARASITOLOGY AND PATHOGENIC BACTERIA

General Parasitology

50 Microscope Slides

Domestic and tropical parasites of humans and animals

1(f). *Entamoeba histolytica*, amoebic dysentery, smear or section 2(f). *Leishmania donovani*, causes Kala-Azar, smear or section 3(f). *Trypanosoma gambiense*, sleeping disease, blood smear 4(f). *Trypanosoma cruzi*, Chagas disease, blood smear 5(f). *Plasmodium falciparum*, human malaria, blood smear with ring stages 6(f). *Plasmodium berghei*, blood smear with vegetative forms and schizogony stages 7(g). *Plasmodium* sp., malaria melanemia in human spleen 8(f). *Toxoplasma gondii*, causing toxoplasmosis, smear or section of cyst 9(f). *Babesia canis*, blood smear 10(f). *Sarcocystis* sp., section of muscle showing the parasites in Miescher's tubes 11(e). *Nosema apis*, honey bee dysentery, t.s. of bee intestine 12(d). *Monocystis agilis*, from earthworm seminal vesicle 13(d). *Eimeria stiedae*, causes coccidiosis in rabbit liver, t.s. 14(f). *Fasciola hepatica*, beef liver fluke, w.m. of adult flat mount 15(c). *Fasciola*, typical t.s. of body in different regions 16(d). *Fasciola*, ova w.m. 17(h). *Fasciola*, miracidia w.m. * 18(h). *Schistosoma mansoni*, bilharziosis, adult male or female w.m. 19(g). *Schistosoma*, t.s. of snail liver with redia and cercaria * 20(e). *Schistosoma mansoni*, ova in faeces 21(t). *Taenia* or *Moniezia*, tapeworm, scolex w.m. 22(f). *Taenia pisiformis*, dwarf tapeworm, mature proglottids w.m. 23(d). *Taenia saginata*, tapeworm, proglottids in different stages t.s. 24(d). *Taenia saginata*, ova in faeces w.m. 25(f). *Hymenolepis nana*, proglottids w.m. 26(f). *Echinococcus granulosus*, dog tapeworm, scolices from cyst w.m. 27(f). *Echinococcus*, cyst wall and scolices t.s. 28(d). *Ascaris lumbricoides*, roundworm of human, adult female t.s. in region of gonads 29(d). *Ascaris lumbricoides*, adult male t.s. in region of gonads 30(d). *Ascaris lumbricoides*, ova from faeces w.m. 31(f). *Enterobius vermicularis* (*Oxyuris*), pin worm, adult specimen w.m. 32(d). *Trichinella spiralis*, muscle with encysted larvae l.s. 33(h). *Ancylostoma*, hookworm, adult w.m. 34(d). *Trichuris trichiura*, whip worm, ova w.m. 35(e). *Strongyloides*, larvae w.m. 36(f). *Heterakis spumosa*, intestinal parasite of rat, adult 37(g). *Ixodes* sp., tick, adult w.m. Carrier of relapsing fever and borreliosis 38(d). *Dermanyssus gallinae*, chicken mite w.m. 39(e). *Acarapis woodi*, varroa, parasitic mite of honey bee, w.m. 40(e). *Sarcoptes scabiei*, section of diseased skin with parasites 41(e). *Stomoxys calcitrans*, stable fly, piercing sucking mouth parts w.m. 42(f). *Anopheles*, malaria mosquito, mouth parts of female w.m. 43(e). *Culex pipiens*, common mosquito, mouth parts of female w.m. 44(f). *Anopheles*, larva w.m. 45(d). *Culex pipiens*, larva w.m. 46(d). *Culex pipiens*, pupa w.m. 47(f). *Cimex lectularius*, bed bug, w.m. 48(f). *Pediculus humanus*, human louse, w.m. 49(e). *Pediculus humanus*, louse eggs attached to the hair, w.m. 50(e). *Ctenocephalus canis*, dog flea, adult w.m.

9982-1004248

General Parasitology, Short Set

25 preparations with accompanying guide.

For details, please go to www.3bscientific.com.

9982-1004266

Pathogenic Bacteria

25 Microscope Slides

1(e). *Diplococcus pneumoniae*, croupous pneumonia, smear 2(f). *Neisseria gonorrhoeae*, gonorrhoea, smear 3(e). *Neisseria meningitidis* (intracellularis), epidemic meningitidis, smear 4(d). *Staphylococcus aureus*, pus organism, smear 5(d). *Streptococcus pyogenes*, smear showing short chains 6(d). *Corynebacterium diphtheriae*, smear 7(e). *Mycobacterium tuberculosis*, smear from positive sputum stained after Ziehl-Neelsen

8(e). *Bacterium erysipelas*, smear 9(d). *Brucella abortus*, abortion in cattle (Bang disease), smear 10(d). *Proteus vulgaris*, inflammation of urinary system, smear 11(d). *Escherichia coli*, colon bacteria, possibly pathogen, smear 12(d). *Eberthella typhi*, typhoid fever, smear 13(d). *Salmonella paratyphi*, paratyphoid fever, smear 14(d). *Hemophilus influenzae* (Pfeiffer), smear 15(e). *Klebsiella pneumoniae* (Friedlander), pneumonia, smear 16(f). *Pasteurella (Yersinia) pestis*, bubonic plague, smear 17(d). *Salmonella enteritidis*, meat poisoning, smear 18(d). *Shigella dysenteriae*, bacillary dysentery, smear 19(d). *Bacillus anthracis*, wool sorter's disease, smear 20(e). *Clostridium botulinum*, food poisoning, smear 21(d). *Clostridium septicum*, smear 22(e). *Clostridium tetani*, lockjaw, smear 23(d). *Clostridium perfringens*, gas gangrene, smear 24(f). *Vibrio comma*, Asiatic cholera, smear 25(g). *Borrelia duttoni* (*Spirochaeta recurrentis*), Central African relapsing fever, blood smear.

9982-1004249

Bacteria Basis Set

25 Microscope Slides

The most important pathogenic and non-pathogenic bacteria 1(d). *Staphylococcus aureus*, pus organism 2(d). *Sarcina lutea*, chromogenic rods 3(e). *Streptococcus pyogenes*, pus organism 4(d). *Streptococcus lactis*, milk souring organism 5(d). *Bacillus subtilis*, hay bacillus, smear with bacilli and spores 6(d). *Bacillus mycoides*, soil organism 7(e). *Bacillus anthracis*, wool sorters disease 8(e). *Mycobacterium tuberculosis*, tuberculosis 9(d). *Corynebacterium diphtheriae*, diphtheria 10(e). *Bacterium erysipelas*, red murrain 11(d). *Rhizobium radicicola*, nitrogen fixing bacteria 12(d). *Proteus vulgaris*, putrefaction 13(d). *Escherichia coli*, colon bacteria 14(d). *Eberthella typhi*, typhoid fever 15(d). *Salmonella paratyphi*, paratyphoid fever 16(f). *Vibrio comma*, Asiatic cholera 17(d). *Shigella dysenteriae*, bacillary dysentery 18(d). *Hemophilus influenzae*, Pfeiffer bacillus 19(e). *Spirillum volutans*, from putrid water 20(d). *Rhodospirillum rubrum*, chromogenic spirilli 21(e). *Clostridium botulinum* (botulism), food poisoning 22(g). *Spirochaeta duttoni* (*Borrelia recurrentis*), in blood smear 23(d). Bacteria from mouth, with Gram positive and negative rods 24(d). Bacteria from bread 25(d). Bacteria from cheese.

9982-1003969

BOTANY

Cryptogamae, Elementary Set

25 Microscope Slides

1(e). Bacteria type slide shows cocci, bacilli, spirilli 2(c). *Oscillatoria*, blue green alga 3(c). *Pleurococcus*, green alga 4(d). *Eudorina*, small colonies 5(c). Diatoms, mixed species 6(e). *Spirogyra* in conjugation with zygotes 7(d). *Fucus*, brown alga, female conceptacle with oogonia t.s. 8(d). *Fucus*, male conceptacle with antheridia t.s. 9(c). *Mucor*, black mold, mycelium and sporangia 10(c). *Peziza*, apothecium with asci t.s. 11(e). *Claviceps purpurea*, ergot, stroma with perithecia l.s. 12(c). *Morchella*, morel, fruiting body t.s. 13(b). *Saccharomyces*, yeast, budding 14(c). *Psalliota*, gill fungus, pileus with lamellae t.s. 15(c). *Coprinus*, mushroom, t.s. typical basidia and spores 16(d). *Lobaria pulmonaria*, foliose lichen, thallus with symbiotic algae t.s. 17(d). Moss stem with leaves w.m. 18(d). *Marchantia*, liverwort, thallus with cupule and gemmae l.s. 19(d). *Marchantia*, antheridia l.s. 20(d). *Marchantia*, archeogonia l.s. 21(d). *Polytrichum*, moss, capsule with spores t.s. 22(d). *Equisetum*, horsetail, strobilus with spores l.s. 23(c). *Aspidium* (*Dryopteris*), fern, stem t.s. 24(d). *Aspidium*, leaf with sporangia and spores t.s. 25(d). Fern prothallium w.m.

9982-1004250

Cryptogamae, Supplementary Set I

25 preparations with accompanying guide.

For details, please go to www.3bscientific.com.

9982-1004251

Cryptogamae, Supplementary Set II

25 preparations with accompanying guide.

For details, please go to www.3bscientific.com.

9982-1004252

Phanerogamae, Elementary Set

25 Microscope Slides

1(c). Simple plant cells, epidermis of *Allium* w.m. 2(d). Cell division (mitosis) all stages, in *Allium* root tips l.s. 3(c). Starch grains, t.s. of potato tuber 4(c). Cork cells, t.s. of bark of *Quercus* 5(d). Stone cells, t.s. of fruit of pear 6(d). Root hairs on root tip 7(c). *Zea mays*, corn, typical monocot root t.s. 8(c). *Ranunculus*, buttercup, typical dicot root t.s. 9(c). *Zea mays*, corn, monocot stem t.s. 10(c). *Triticum*, wheat, gramineous stem t.s. 11(c). *Aristolochia*, birthwort, one year stem t.s. 12(c). *Aristolochia*, older stem t.s. 13(d). *Cucurbita*, pumpkin, stem with bundles and sieve tubes l.s. 14(c). *Sambucus*, elderberry, stem with lenticels t.s. 15(c). *Tulipa*, tulip, leaf epidermis with stomata w.m. 16(c). *Zea mays*, corn, leaf t.s., monocot gramineous leaf 17(c). *Syringa*, lilac, leaf t.s., dicot leaf 18(c). *Fagus*, beech, leaf bud t.s. shows leaf origin 19(d). *Lilium*, lily, flower bud t.s. shows flower diagram 20(d). *Lilium*, anthers t.s. shows pollen chambers and pollen grains 21(d). *Lilium*, ovary t.s. with embryosac 22(e). *Lilium*, stigma with pollen and pollen tubes l.s. 23(c). *Pinus*, pine, leaf (needle) t.s. 24(d). *Triticum*, wheat, grain (semen) t.s. with embryo and endosperm 25(d). *Capsella*, shepherd's purse, l.s. of embryos in situ.

9982-1004253

Phanerogamae, Supplementary Set

50 preparations with accompanying guide.

For details, please go to www.3bscientific.com.

9982-1004254

Algae

30 Microscope Slides

Cyanophyceae 1(c). *Chroococcus*, a single-cell alga, w.m. 2(c). *Anabaena*, w.m. of filaments with heterocysts 3(d). *Nostoc* sp., t.s. of colony with hormogonia 4(d). *Aphanizomenon*, w.m. showing heterocysts 5(c). *Scytonema*, unbranched filaments with false branching, w.m. 6(d). *Stigonema*, branching filaments, w.m. *Chromophyta* 7(c). Diatoms, fresh water, recent, mixed 8(d). Diatoms, showing protoplasmic structure *Conjugatae* 9(c). *Spirogyra*, vegetative filaments w.m. 10(e). *Spirogyra*, scalariform conjugation and zygotes following conjugation, w.m. 11(c). *Zygnema*, w.m. of vegetative filaments 12(e). *Desmids*, strewn slide showing several forms *Chlorophyceae* 13(c). *Chlamydomonas*, biflagellate cells, w.m. 14(d). *Pandorina morum*, biflagellate cells in a spherical colony, w.m. 15(e). *Volvox*, spherical colonies with daughter cells, w.m. 16(d). *Pediastrum*, stellate colonies, w.m. 17(d). *Oedogonium*, w.m. of filaments with sex organs, macrandrous 18(c). *Cladophora*, with multinucleate cells 19(c). *Draparnaldia glomerata*, filaments with clusters of branches 20(d). *Ulva lactuca*, green alga showing thallus of one celled layer 21(d). *Vaucheria*, w.m. of oogonia and antheridia *Charophyceae* 22(d). *Chara vulgaris*, thallus with sex organs *Phaeophyceae* 23(e). *Fucus serratus*, antheridia and oogonia t.s. on one slide 24(d). *Fucus spiralis*, monocious, t.s. of conceptacle with oogonia and antheridia 25(d). *Ectocarpus*, plurilocular, w.m. 26(c). *Laminaria saccharina*, thallus with sporangia t.s. *Rhodophyceae* 27(d). *Polysiphonia*, thallus with antheridia 28(d). *Polysiphonia*, thallus with cystocarps 29(d). *Polysiphonia*, thallus with tetraspores 30(d). *Batrachospermum*.

9982-1003970

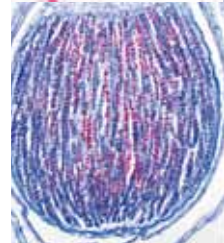
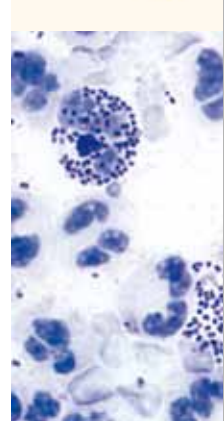
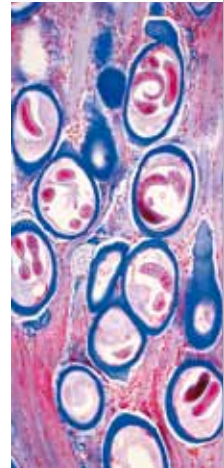

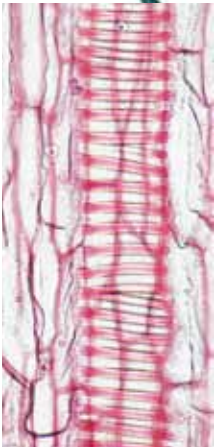
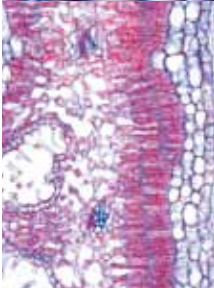
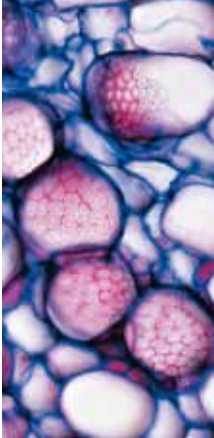
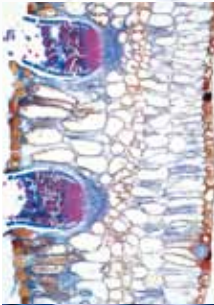

Fungi and Lichen

20 Microscope Slides

Phycomycetes 1(c). *Mucor mucedo*, w.m. of hyphae showing sporangia 2(d). *Rhizopus nigricans*, w.m. of hyphae with developing zygotes (d). *Synchytrium endobioticum*, potato black wart, t.s. of infected tissue 4(c). *Plasmodiophora*, t.s. of cabbage rot Ascomycetes 5(c). *Claviceps purpurea*, t.s. of sclerotium 6(c). *Tuber rufum*, truffle, t.s. of fruiting body showing asci 7(c). *Peziza* sp., cup-fungus, t.s. of fruiting body with asci 8(d). *Erysiphe* sp., mildew, t.s. of leaf with perithecia 9(d). *Penicillium* sp., blue mold on orange-rind, t.s. of hyphae with conidiophores 10(c). *Aspergillus glaucum*, brown-mold, w.m. of hyphae with sporangia 11(b). *Saccharomyces* sp., yeast, budding, w.m. 12(d). *Taphrina pruni* (*Exoascus pruni*), plum pockets, t.s. with haustoria and asci Basidiomycetes 13(d). *Puccinia graminis*, t.s. of uredinia on wheat 14(d). *Puccinia graminis*, wheat rust, t.s. of aecidia on infected barberry leaf 15(d). *Ustilago zeae*, corn smut, infected tissue, t.s. 16(c). *Psalliota* sp., mushroom, l.s. through pileus and lamellae 17(c). *Boletus edulis*, pore fungus, l.s. through pores 18(c). *Lycoperdon gemmatum*, puff-ball, t.s. of fruiting body lichens 19(d). *Xanthoria*, lichen, t.s. of thallus showing hyphae with symbiotic algae 20(d). *Xanthoria*, t.s. of apothecium.

9982-1003971

Bryophyta (Liverworts and Mosses)

15 preparations with accompanying guide.

For details, please go to www.3bscientific.com.

9982-1003972

Bryophyta (Liverworts and Mosses)

15 preparations with accompanying guide.

For details, please go to www.3bscientific.com.

9982-1003973

Arrangement and Types of Vascular Bundles

13 preparations with accompanying guide.

For details, please go to www.3bscientific.com.

9982-1004255

Angiospermae I. Gymnospermae

15 Microscope Slides

1(e). *Ephedra*, male cone l.s. 2(f). *Ephedra*, female cone at pollination time l.s. 3(c). *Ginkgo*, young sprout, t.s. 4(c). *Ginkgo*, leaf t.s. 5(c). *Pinus*, pine, young root 6(c). *Pinus*, pine, first year stem 7(e). *Pinus*, pine, bud showing vascular anatomy and origin of leaves l.s. 8(d). *Pinus*, pine, wood, transverse, radial and tangential sections 9(c). *Pinus*, pine, needles (leaves) t.s. 10(b). *Pinus*, pine, w.m. of mature pollen grains 11(d). *Pinus*, pine, male cone l.s. 12(d). *Pinus*, pine, young female cone l.s. 13(c). *Larix*, larch, t.s. of needles (leaves) t.s. 14(d). *Larix*, larch, male cone l.s. 15(e). *Larix*, larch, female cone with ovules l.s.

9982-1003974

Angiospermae II. Cells and Tissues

20 Microscope Slides

1(c). Epidermal cells of *Allium* (onion), flat mount shows typical plant cells with nuclei, cytoplasm and cell walls 2(d). Mitosis, l.s. from *Allium* root tips showing all stages of plant mitosis 3(f). Meiosis, t.s. of *Lilium* anthers showing different stages of meiosis 4(d). Stem apex and meristematic tissue of *Asparagus* l.s. 5(d). Chloroplasts, w.m. of leaf of *Elodea* or *Spinacea* showing detail of large chloroplasts 6(c). Chromoplasts, t.s. of root of *Daucus* (carrot) 7(c). Aleurone grains, t.s. of *Ricinus* endosperm 8(b). Starch grains, different kinds mixed w.m. 9(d). Fat, t.s. of endosperm of *Corylus* (hazel) stained for fat 10(d). Inulin crystals, t.s. of tuber of *Dahlia* 11(d). Acid tannic, t.s. bark of *Rosa* 12(b). Calcium oxalate crystals in w.m. of dry *Allium* scale 13(d). Annular and spiral vessels, isolated and w.m. 14(c). Wood cells, macerated and w.m. 15(c). Lactiferous vessels, l.s. stem of *Euphorbia* (spurge) 16(b). Cork cells, t.s. bark of *Quercus suber* (oak) 17(b). Scale-like stellate hairs, isolated from *Elaeagnus* (olive tree) 18(c). Lysigenous oil glands, t.s. rind of *Citrus* fruit 19(b). Parenchyma cells, t.s. of marrow of *Sambucus* (elderberry) 20(d). Stone cells, t.s. fruit of *Pyrus* (pear).

9982-1003975

Angiospermae III. Roots

15 Microscope Slides

1(d). *Allium cepa*, onion, root tips, l.s. showing all stages of mitosis 2(c). *Zea mays*, corn, t.s. of typical monocot root 3(c). *Iris*, t.s. of typical monocot root 4(c). *Ranunculus*, buttercup, t.s. of a typical dicot root 5(c). *Sarothamnus*, broom, t.s. through woody root 6(c). *Taraxacum*, dandelion, t.s. through tap root showing lactiferous ducts 7(d). *Vicia faba*, bean, root nodule t.s. nitrogen fixing bacteria 8(d). *Ranunculus ficaria*, tuber during fall season, t.s. showing starch 9(d). *Alnus*, alder, t.s. of tuber showing actinomycetes 10(d). *Neottia*, orchid, t.s. of root with endotrophic mycorrhiza 11(d). *Cuscuta*, dodder, on host, t.s. haustorium 12(d). Root hairs, w.m. of root tip, root cap and root hairs 13(d). *Zea mays*, root tip, median l.s. showing central pith, cap and starch 14(c). *Monstera*, aerial root t.s. 15(c). *Elodea*, Canadian waterweed, t.s. of an aquatic root.

9982-1003976

Angiospermae IV. Stems

20 Microscope Slides

1(c). *Canna*, t.s. of typical monocot stem with scattered bundles 2(f). *Aristolochia*, t.s. of one year, two years stem and older stem, all 3 on one slide 3(e). Dicot and monocot stem, t.s. of *Helianthus* and *Canna* 4(e). Dicot and monocot stem, t.s. of *Ranunculus* and *Zea* 5(e). *Tilia*, lime, two t.s. of stems, first year and two years 6(d). *Fagus silvatica*, beech, three sections of wood, t.s., r.l.s., t.l.s. 7(d). *Fraxinus excelsior*, ash, three sections of wood, t.s., r.l.s., t.l.s. 8(c). *Quercus*, oak, t.s. of stem showing cambium and bark 9(c). *Sambucus*, elder, t.s. of bark showing lenticells 10(c). *Linum*, flax, t.s. of stem showing husk fibres 11(b). *Linum*, flax, isolated husk fibres, w.m. 12(d). *Ranunculus*, l.s. of herbaceous stem 13(d). *Cucurbita pepo*, l.s. of stem with sieve tubes 14(d). Sieve plates in top view, t.s. of *Cucurbita* stem 15(c). *Lamium*, t.s. of square stem, collenchyma 16(c). *Secale*, rye, t.s. of typical grass stem 17(c). *Nymphaea*, water lily, t.s. of aquatic stem, spicular cells 18(c). *Hippuris*, t.s. of typical aquatic stem with large central pith 19(d). *Urtica*, nettle, stinging hairs with poison ducts 20(c). *Solanum tuberosum*, potato, t.s. of tuber with starch grains and cork.

9982-1003977

Angiospermae V. Leaves

15 Microscope Slides

1(d). Elodea, l.s. of stem tip showing apical meristem and origin of leaves 2(d). Leaves, monocot and dicot, Zea and Ranunculus, t.s. 3(c). Syringa, lilac, t.s. of typical dicot leaf 4(c). Iris, typical isobilateral leaf t.s. 5(c). Eucalyptus, a bifacial foliage leaf with schizogenous oil glands t.s. 6(d). Fagus, beech, t.s. of sun and shade leaves on one slide 7(c). Calluna, ling, t.s. of rolled leaf showing sunken stomata 8(c). Nerium oleander, t.s. of leaf showing sunken stomatal pits lined with protective hairs 9(c). Ficus elastica, rubber plant, t.s. of leaf showing cystoliths 10(c). Elodea, t.s. of leaf showing the simple structure of an aquatic leaf 11(c). Tulipa, tulip, epidermis w.m. showing stomata 12(d). Aesculus, t.s. of leaf bud with squama and embedded folded leaves 13(d). Drosera, sundew, w.m. of leaf with glandular hairs 14(d). Nepenthes, t.s. of pitcher with glands 15(d). Utricularia, bladderwort, w.m. of bladder.

9982-1003978

Angiospermae VI. Flowers

15 preparations with accompanying guide.

For details, please go to www.3bscientific.com.

9982-1003979

Angiospermae VII. Fruits and Seeds

15 preparations with accompanying guide.

For details, please go to www.3bscientific.com.

9982-1003980

CYTOLOGY AND EMBRYOLOGY

The Animal Cell

12 Microscope Slides

1(c). Squamous epithelium, isolated cells from human mouth 2(d). Striated muscle l.s. showing nuclei, striations 3(d). Compact bone and hyaline cartilage t.s., two sections for comparison 4(e). Nerve fibres isolated, fixed and stained by osmic acid to show myelin sheaths and Ranvier's nodes 5(d). Liver of Salamandra t.s., simple animal cells 6(f). Kidney of mouse, t.s. vital stained to demonstrate storage 7(d). Ovary of cat, t.s. showing primary, secondary, and Graafian follicles 8(d). Testis of frog, t.s. showing spermatogenesis 9(e). Salamandra larva, t.s. of skin and other organs selected to show cell division (mitosis) 10(f). Uteri of Ascaris megalocephala, t.s. stained to show meiosis with chromosomes and nuclear spindles 11(f). Salivary gland of Chironomus larva. Giant chromosomes showing large chromomeres. Stained for DNA after Feulgen 12(e). Ova from Psammechinus (sea urchin). Unfertilized ova, fertilized ova, early cleavage stages.

9982-1003981

Plant Cell

12 Microscope Slides

1(c). Epidermis of Allium (onion), w.m. showing simple plant cells with cell walls, nuclei and cytoplasm 2(d). Root tips of Allium cepa l.s. showing cell division (mitosis) in all stages 3(e). Pollen mother cells of Lilium. Prophase of first maturation division (meiosis) 4(f). Pollen mother cells of Lilium. Metaphase and anaphase of first maturation division 5(c). Wood of Tilia macerated and w.m. 6(d). Fruit of Pyrus (pear) t.s. showing stone cells 7(c). Tuber of Solanum (potato) t.s. shows cork and starch grains 8(d). Cucurbita pepo (pumpkin) l.s. of stem showing vascular bundles with sieve tubes, spiral and annular vessels 9(c). Ricinus endosperm t.s. showing aleurone grains 10(d). Anthers of Lilium (lily), t.s. pollen sacs and pollen grains 11(d). Ovary of Lilium (lily), t.s. arrangement of ovules and embryosac 12(e). Spirogyra showing conjugation stages and zygotes.

9982-1003982

Set of Genetic Slides

25 Microscope Slides

1(d). Allium, root tips, l.s. showing all stages of mitosis 2(e). Eschscholtzia, stigma, w.m. showing penetrating pollen 3(e). Lilium, microspore mother cells, first division, leptotene to zygotene 4(e). Lilium, first division, diakinesis to telophase 5(f). Lilium, second division, interkinesis to tetrad stage 6(f). Polytrichum, moss, archegonium, w.m. 7(f). Polytrichum, moss, archegonium, l.s. 8(e). Spirogyra scalariform conjugation showing zygotes following conjugation 9(d). Sea urchin, developing of eggs, w.m. of most stages up to pluteus 10(f). Giant chromosomes from salivary gland of Chironomus, squash preparation stained for chromomeres 11(f). Giant chromosomes, section 12(e). Ascaris, fertilisation of eggs, t.s. 13(f). Ascaris, male and female pronuclei, t.s. 14(f). Ascaris, meiosis and early cleavage, t.s. 15(e). Testis of crayfish, t.s. showing meiosis 16(d). Testis of mouse, t.s. showing spermatogenesis 17(d). Ovary of rabbit, l.s. showing follicles in various stages 18(f). Embryology of fish, l.s. of embryo showing animal mitosis 19(h). Chromosomes, human, female, of culture of peripheral blood 20(i). Chromosomes, human, male, of culture of peripheral blood 21(f). Drosophila genetics, adult wild type, w.m. 22(f). Drosophila genetics, "barr eye" mutant, w.m. 23(f). Drosophila genetics, "brown eye" mutant, w.m. 24(f). Drosophila genetics, "vestigial wing" mutant, w.m. 25(f). Drosophila genetics, "white eye" mutant, w.m.

9982-1003983

Sea Urchin Embryology (Psammechinus miliaris)

12 preparations with accompanying guide.

For details, please go to www.3bscientific.com.

9982-1003984

Frog Embryology (Rana)

10 preparations with accompanying guide.

For details, please go to www.3bscientific.com.

9982-1003985

Chicken Embryology (Gallus domesticus)

10 preparations with accompanying guide.

For details, please go to www.3bscientific.com.

9982-1003986

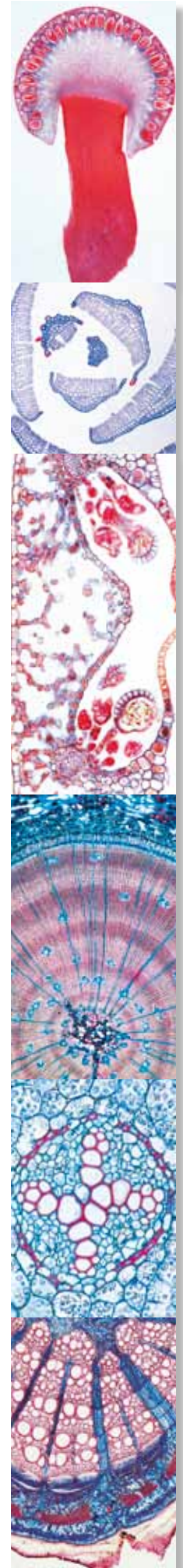

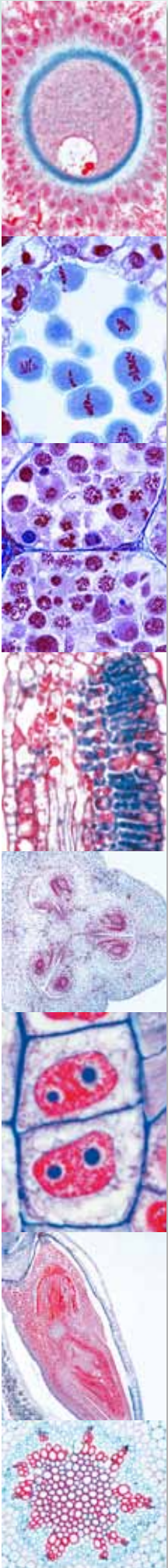
**Pig Embryology (*Sus scrofa*)**

10 preparations with accompanying guide.
For details, please go to www.3bscientific.com.

9982-1003987

NEW**Mitosis and Meiosis Set I**

6 selected Microscope Slides. With depicted accompanying brochure

1(d). Mitosis, I.s. from *Allium* root tips showing plant mitosis stained with iron-hematoxyline 2(f). Mitotic stages in sec. of red bone marrow 3(e). Meiotic and mitotic stages in sec. of *Salamandra testis* 4(f). *Lilium*, anther t.s., microspore mother cells showing telophase of first and prophase of second division 5(f). Giant chromosomes, smear from salivary gland of *Chironomus* 6(f). *Ascaris megaloglyphy* embryology. Sec. of uteri showing maturation stages.

9982-1013468

NEW**Mitosis and Meiosis Set II**

5 selected Microscope Slides. With depicted accompanying brochure

1(d). Mitosis, I.s. from *Vicia faba* (bean). root tips showing all mitotic stages. Iron hematoxyline 2(f). *Lilium*, anther t.s., microspore mother cells showing telophase of first and prophase of second division 3(h). Mitotic stages in sec. of whitefish blastula showing spindles 4(f). Spermatogenesis with meiotic and mitotic stages, sec. of testis of grasshopper 5(g). *Paramecium*, in fission, nuclei stained.

9982-1013474

NEW**The *Ascaris megaloglyphy* Embryology**

10 Microscope Slides. With depicted accompanying brochure

1(d). Cell division in I.s. of *Allium* root tips, showing all mitotic stages 2(e). *Ascaris*, primary germ cells in the growing zone of oviduct 3(f). *Ascaris*, entrance of sperm in the oocytes 4(f). *Ascaris*, first and second maturation divisions in oocytes I, 5(f). *Ascaris*, dito. in oocytes II 6(f). *Ascaris*, mature oocytes with male and female pronuclei 7(f). *Ascaris*, early cleavage stages 8(f). *Ascaris*, later cleavage stages 9(d). *Ascaris*, adult female, t.s. in region of gonads 10(d). *Ascaris*, adult male roundworm, t.s. in region of gonads.

9982-1013479

NEW**Development of the Microspore Mother Cells of *Lilium candidum***

12 Microscope Slides. With depicted accompanying brochure

1(e). Leptotene, the chromosomes appear as fine threads 2(e). Zygotene, the homologous chromosomes associate in pairs 3(e). Pachytene, complete pairing of the chromosomes 4(e). Diplotene, shortening of the chromosomes by contraction. Interchange of chromatin (crossing over) 5(e). Diakinesis, further contraction of the bivalents 6(f). Metaphase and anaphase of the first (heterotypic). division 7(f). Telophase of the first and prophase of the second division 8(f). Metaphase and anaphase of the second (homeotypic). division 9(f). Pollen tetrads after the second division, each bearing the haploid number of chromosomes 10(e). Uninucleate microspores 11(e). Mature two-nucleate pollen grains at the time of shedding 12(b). Mature pollen grains, w.m. to show structure of the cell walls.

9982-1013484

ECOLOGY AND ENVIRONMENT**The Forest, Consequences of Pollution**

20 Microscope Slides

1(c). Pine (*Pinus*), healthy leaves, t.s. 2(c). Pine (*Pinus*) leaves damaged by acid rain, t.s. 3(c). Fir (*Abies*), healthy leaves, t.s. 4(c). Fir (*Abies*), stem tip damaged t.s. 5(c). Beech (*Fagus*), healthy leaves t.s. 6(c). Beech (*Fagus*), t.s. of leaves with destroyed epidermis and chloroplasts 7(d). *Rhytisma acerinum*, tar spot of maples, consequence of single-crop farming 8(d). Early leaf fall, caused by thawing salt 9(d). Healthy lichen, indicator of clean air 10(d). Damaged lichen, caused by air pollution 11(c). Healthy wood of beech, t.s. 12(d). Wood destroyed by fungus 13(d). *Polyporus*, wood rot fungus, fruiting body t.s. 14(d). Root nodules of *Alnus*, with symbiotic bacteria 15(d). Spruce beetle (*Cryphalus picea*), larva t.s. 16(c). Wood with normal annual rings, t.s. 17(c). Wood with anomalous narrow annual rings caused by drought, t.s. 18(d). Bark with larval galleries of spruce beetle, t.s. 19(d). Pineapple-like gall on spruce caused by lice, t.s. 20(d). Gall nut on oak caused by insects, t.s.

9982-1004256

Water Pollution, Problems and Results

20 Microscope Slides

1(d). Intestinal bacteria (*Escherichia coli*) from putrid water 2(e). Putrefactive bacteria (*Spirillum*) from sludge poor in oxygen 3(d). Putrefactive bacteria (*Sphaerotilus*) bacteria, forming long chains 4(d). Sludge bacteria (*Methanobacterium*) causing sewer gas 5(d). Sulphur bacteria (*Thiocystis*) 6(c). Cyanobacteria (*Microcystis*), blue-green algae "bloom" in stagnant water 7(c). *Anabaena*, blue green algae, in eutrophic water 8(c). *Spirogyra*, filamentous green alga in nutrient-rich water 9(d). *Spirulina*, corkscrew-shaped algae occurring in bitter seas 10(c). *Chlamydomonas*, one-celled green alga in eutrophic water 11(c). *Cladophora*, green alga from moderately polluted water 12(c). Diatoms, mixed algae from scarcely polluted water 13(c). *Euglena*, green flagellates occurring in stagnant eutrophic water 14(d). Ciliates, different species from nutrient-rich water 15(d). Rotifers (*Rotatoria*), small animals from putrid water 16(d). *Tubifex*, fresh water oligochaete, living in the sludge 17(d). *Carchesium*, stalked ciliate from moderately polluted water 18(d). Water mold (*Saprolegnia*), harmful to plants and animals 19(d). Skin of fish injured by chemicals, t.s. 20(d). Skin ulcer of an amphibian, t.s.

9982-1004257

Life in the Soil

17 Microscope Slides

1(d). Acidophile soil bacteria, solution of heavy metals 2(d). Nitrite bacteria, forming harmful nitrogenous substances 3(d). Root of beech with ectotrophic mycorrhiza, t.s. 4(d). Root of birch with partly endotrophic mycorrhiza, t.s. 5(d). Root of lupin with symbiotic nitrogen fixing bacteria 6(d). Netted venation, portion of rotted deciduous leaf 7(c). Charlock (*Sinapis*), t.s. of stem. Green manure plant 8(d). Soil bacteria (*Bacillus megaterium*), smear 9(d). Hyphae of root fungi, t.s. 10(d). Lichen, indicator of clean air 11(c). Mushroom (*Xerocomus*), mycelium 12(c). Root of willow (*Salix*), planting protecting against erosion 13(c). Earthworm (*Lumbricus*) t.s., causing soil improvement 14(d). Springtails (*Collembola*), w.m. 15(d). Mite from forest soil, w.m. 16(c). Constituents of humus soil 17(c). Constituents of peaty soil.

9982-1004258

Air Pollution and Allergens

15 Microscope Slides

1(c). Pollen grains of different kinds of grass 2(c). Pollen grains of different deciduous trees 3(c). Pollen grains of different conifers 4(b). Mixed house dust 5(c). Dust mite from a living room 6(b). Spores of different fungi 7(b). Wood powder 8(b). Asbestos powder (carcinogenic) 9(b). Talcum powder 10(b). Crystals of washing-powder 11(b). Polyamide fibres 12(b). Nylon fibres 13(e). Mucous membrane of human nose, t.s. 14(e). Healthy human lung, t.s. 15(e). Human lung injured with dust particles, t.s.

9982-1004259

The Microscopic Life in the Water, Part II

Supplementary to Set No. 7000

Microorganisms living in our waters, 25 preparations with accompanying guide.

For details, please go to www.3bscientific.com.

9982-1004267

The Microscopic Life in the Water Part I

25 Microscope Slides

1(e). Amoeba proteus, amoeba 2(c). Ceratium hirundinella, dinoflagellates 3(c). Euglena, green flagellate with eyespot 4(d). Radiolaria, marine rhizopods 5(c). Paramecium, nuclei stained 6(d). Stylonychia, a common ciliate 7(b). Spongilla, fresh water sponge, isolated spicules 8(d). Hydra, w.m. or section 9(d). Rotatoria, rotifers, mixed species 10(c). Daphnia, water flea, a phyllopod 11(c). Cyclops, a copepod 12(d). Chironomus, gnat, larva w.m. 13(d). Putrefaction causing bacteria from hay infusions 14(c). Oscillatoria, a filamentous blue green alga 15(c). Diatomeae, diatoms, mixed species 16(d). Desmidiaceae, desmids, mixed species 17(c). Spirogyra, green alga with spiral chloroplasts 18(d). Eudorina, small colonies within gelatinous sheaths 19(c). Cladophora, green alga, branched filaments 20(c). Draparnaldia, main filaments and branchings 21(c). Microcystis, irregular colonies 22(c). Ulothrix, green alga with girdle-shaped chloroplasts 23(d). Oedogonium, vegetative filaments 24(e). Volvox, with daughter colonies and sexual stages 25(d). Mesothaenium, rod-shaped desmids.

9982-1004260

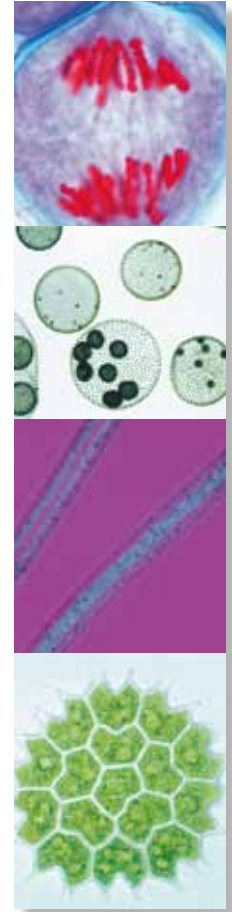

GEOLOGY:

ROCKS AND MINERALS FINELY GROUND

Selected rocks and minerals are ground and polished to a thickness of 20 – 30 µm. The preparations are mounted with Canada balsam on slides of 45x30 mm.

In order to identify forms, colours, refractions and fossil inclusions, the slides can be observed with any normal microscope in transmitting light. Additional information is obtained by using microscopes with polarized-light equipment.

For finely ground rocks and minerals, please order the extra matching Wooden Box 9982-1012499.

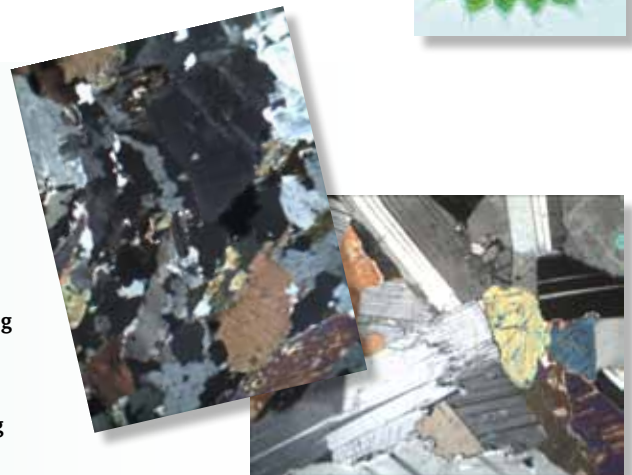

Rocks and Minerals, Basic Set no. I

10 Microscope Slides

(1i). Granite, (2i). Syenite, (3i). Gabbro, (4i). Basalt, (5i). Gneiss, (6i). Micaschist, (7i). Quartzite, (8i). Marble, (9i). Sandstone, (10i). Limestone fossilised.

9982-1012495

Rocks and Minerals, Basic Set no. II

10 Microscope Slides

(1i). Andesite, (2i). Trachyte, (3i). Thylolite, (4i). Diorite, (5i). Microgranite, (6i). Chalk, (7i). Limestone oolitic, (8i). Millstone, (9i). Coal, (10i). Schist.

9982-1012498

Wooden Box

for 12 microscope slides 45x30 mm

9982-1012499

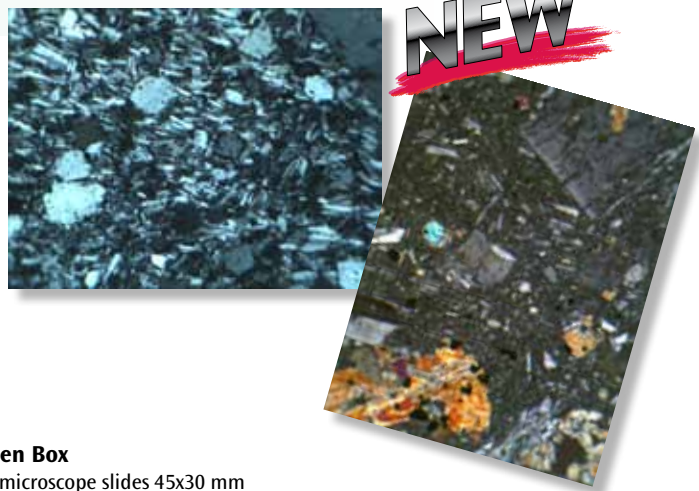

MICROSCOPE SLIDES

Each individual slide presents an exceptionally clear sample which is crafted to very high standards and will be long lasting. We have selected the most interesting and most popular ones for you to choose from. Order your favorite ones and delve into the fascinating world of the microcosm with your students!

Minimum order quantity 10.

 D/E/F/P/S

Please note that microscope slides can only be supplied in our special storage boxes (see p. 109).

Please add box to your purchase order.



9982-1005968

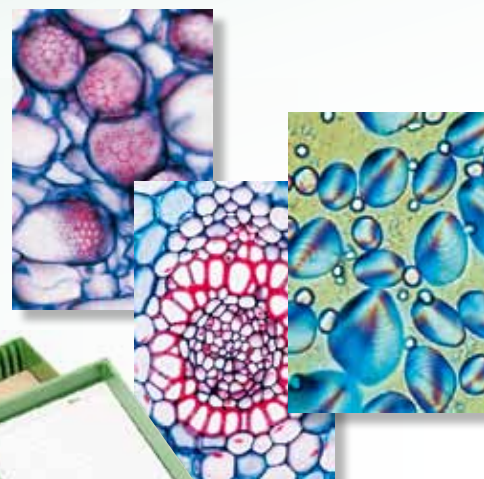

Art. No.	Topic
ZOOLOGY	
9982-1004432	Amoeba proteus, w.m. showing nucleus and pseudopodia
9982-1004437	Euglena, a common flagellate with eyespot
9982-1004442	Paramecium, nuclei stained
9982-1004447	Hydra, w.m. extended specimen to show foot, body, mouth, and tentacles
9982-1004452	Hydra, t.s. of body in different levels. Ectoderm, endoderm
9982-1004457	Lumbricus, earthworm, typical t.s. back of clitellum showing muscular wall, intestine, typhlosole, nephridia etc.
9982-1004462	Daphnia and Cyclops, small crustaceans from fresh water
9982-1004467	Musca domestica, house fly, head and mouth parts (proboscis) w.m.
9982-1004472	Musca domestica, leg with clinging pads (pulvilli)
9982-1004477	Apis mellifica, honey bee, anterior and posterior wing
9982-1004482	Apis mellifica, honey bee, mouth parts of worker w.m.
9982-1004487	Apis mellifica, hind leg of worker with pollen basket w.m.
9982-1004492	Apis mellifica, sting and poison sac w.m.
9982-1004497	Apis mellifica, honey bee, head with compound eyes and brain t.s.
9982-1004502	Branchiostoma lanceolatum (Amphioxus), typical t.s. of body with gills, liver, and gonads

Art. No.	Topic
HISTOLOGY AND ANTHROPOLOGY	
9982-1004507	Compact bone, t.s. special stained for cells, lamellae, and canaliculi
9982-1004512	Striated muscle, l.s. showing nuclei and striations
9982-1004517	Human blood smear, stained for red and white corpuscles
9982-1004522	Artery and vein of mammal, t.s.
9982-1004527	Lung of cat, t.s. showing alveoli, bronchial tubes
9982-1004532	Oesophagus of cat, t.s. with stratified squamous epithelium, muscular layers
9982-1004537	Stomach of cat, t.s. through fundic region showing gastric glands
9982-1004542	Small intestine of cat, t.s. showing mucous membrane
9982-1004547	Large intestine (colon), t.s. special stained for the mucous cells
9982-1004552	Liver of pig, t.s. showing well developed connective tissue
9982-1004557	Pancreas of pig, sec. showing islets of Langerhans
9982-1004562	Kidney of cat, t.s. through cortex and medulla
9982-1004567	Ovary of cat, t.s. with primary, secondary and Graafian follicles
9982-1004572	Testis of mouse, t.s. showing spermatogenesis in all stages
9982-1004577	Sperm of bull (spermatozoa), smear
9982-1004582	Spinal cord of cat, t.s. showing white and grey matter, nerve cells
9982-1004587	Cerebrum, human, t.s. of cortex showing pyramidal cells and fibrous region
9982-1004592	Retina of cat, t.s. for detail of rods and cones
9982-1004597	Tongue of rabbit, t.s. of papilla foliata with abundant taste buds
9982-1004602	Human skin from palm, v.s. showing cornified epidermis, germinative zone, sweat glands

Art. No.	Topic
BACTERIA AND LOWER PLANTS	
9982-1004607	Bacteria from mouth, smear Gram stained showing bacilli, cocci, spirilli, spirochaetes
9982-1004612	Streptococcus lactis, milk souring organisms, smear showing chains
9982-1004617	Diatoms, strewn slide of mixed species
9982-1004622	Nostoc, blue green alga, filamentous colonies within gelatinous sheaths
9982-1004627	Spirogyra, vegetative filaments with spiral chloroplasts
9982-1004632	Volvox, with daughter colonies and sexual stages, w.m.
9982-1004637	Saccharomyces, yeast, budding cells w.m.
9982-1004642	Physcia, foliose lichen, thallus with symbiotic algae t.s.
9982-1004647	Sphagnum, peat moss, w.m. of leaf showing chlorophyll-bearing and hyaline cells

FLOWERING PLANTS

9982-1004652	Lupinus, lupin, root nodules with symbiotic bacteria t.s.
9982-1004657	Root tip and root hairs
9982-1004662	Zea mays, corn, typical monocot root t.s.
9982-1004667	Ranunculus, buttercup, typical dicot root t.s., central stele
9982-1004672	Zea mays, corn, monocot stem with scattered bundles t.s.
9982-1004677	Helianthus, sunflower, typical herbaceous dicot stem t.s.
9982-1004682	Aristolochia, older stem t.s. shows secondary growth
9982-1004687	Cucurbita, pumpkin, l.s. of stem with sieve tubes, annular and reticulate vessels, sclerenchyme fibres
9982-1004692	Pinus, pine, three sections of wood: transverse, radial, tangential
9982-1004697	Tilia, lime, three sections of wood: transverse, radial, tangential
9982-1004702	Tulipa, tulip, epidermis of leaf with stomata and guard cells w.m., surface view
9982-1004707	Iris, typical monocot isobilateral leaf, t.s.
9982-1004712	Syringa, lilac, leaf t.s. showing epidermis, palisade parenchyma, spongy parenchyma, vascular bundles
9982-1004717	Fagus, beech, sun and shade leaves, two t.s. for comparison
9982-1004722	Nerium, oleander, xerophytic leaf with sunken stomata, t.s.
9982-1004727	Lilium, lily, anthers with pollen grains and pollen sacs t.s.
9982-1004732	Lilium, ovary t.s. showing arrangement of ovules
9982-1004737	Triticum, wheat, grain (seed) sagittal l.s. with embryo and endosperm
9982-1004742	Taraxacum, dandelion, composite flower l.s.
9982-1004747	Pinus, pine, male cone with pollen l.s.
9982-1004752	Pinus, female cone with ovules l.s.

Art. No.	Topic
CYTOLOGY AND GENETICS, EMBRYOLOGY	
9982-1004757	Mitochondria, in thin sec. through liver or kidney, special staining technique
9982-1004762	DNA in cell nuclei, demonstrated by Feulgen staining technique
9982-1004767	Giant chromosomes from the salivary gland of Chironomus. Individual genes and puffs can be observed
9982-1004772	Human chromosomes, spread in the stage of metaphase, for counting chromosomes
9982-1004777	Spinal cord of cat, t.s. silvered for nerve cells and fibres
9982-1004782	Allium cepa, l.s. of root tips showing cell divisions (mitosis) in all stages, carefully stained
9982-1004787	Chloroplasts, in leaf of Elodea or Mnium, special stained
9982-1004792	Sea-urchin development (Psammechinus miliaris), composite slide with two cell, four cell and eight cell stages
9982-1004797	Sea-urchin development (Psammechinus miliaris), composite slide with morula, blastula and gastrula stages
9982-1004802	Frog embryology (Rana spec.), sec. trough the blastula stage showing the blastocoel
9982-1004807	Frog embryology (Rana spec.), sag. sec. through young larva in the tail bud stage, with primordia of organs
9982-1004812	Chicken embryo, 48 hour, t.s. with neural tube and chorda
9982-1004817	Embryo of mouse, sagittal l.s. of entire specimen showing all organs in situ

PARASITES AND PATHOGENS

9982-1004822	Escherichia coli, bacteria from colon, probably pathogenic, smear Gram stained
9982-1004827	Eberthella typhi, causing typhoid fever, smear from culture, Gram stained
9982-1004832	Plasmodium berghei, malaria parasite, blood smear
9982-1004837	Trypanosoma gambiense, causing sleeping disease, blood smear
9982-1004842	Culex pipiens, mosquito, head and piercing-sucking mouth parts of female, w.m.
9982-1004847	Tuberculous lung, t.s. of diseased human lung showing milary tubercles in tissue
9982-1004852	Coal dust lung (Anthraxosis pulmonum), t.s. of human smoker's lung
9982-1004857	Liver cirrhosis of man caused by alcohol abuse, t.s. showing degeneration of liver cells
9982-1004862	Arteriosclerosis, t.s. of diseased human coronary artery showing sclerotic changes in the arterial wall

ECOLOGY AND ENVIRONMENT, PESTS IN AGRICULTURE

9982-1004867	Varroa, parasitic mite of bees w.m.
9982-1004872	Leaf (needle) of fir (Abies), two t.s. of leaves, healthy and damaged by environmental influences (acid rain)
9982-1004877	Leaf of beech (Fagus), two t.s. of leaves, healthy and damaged by environmental influences (acid rain)

Multimedia-Packages

for School and Higher-Education

English version –
German version available on request

Multimedia-Packages for Teachers and Students

LIEDER offers a new range of MULTIMEDIA PACKAGES OF LIFE SCIENCE for interactive learning and teaching in school and higher-education. These new packs aim to give a strictly outlined synopsis of all areas of biology important for teaching at schools, colleges and universities and suitable for working with the microscope. Well selected media packages of 6 and 12 units with microscope slides, overhead transparencies, sketch and work sheets, descriptions and pictures of the drawings to support the teacher during lessons. We offer TEACHER PACKAGES and STUDENT SETS.



The teacher packages comprise all necessary media for classroom work:

1. Set of selected prepared microscope slides in plastic box. Prepared Microscope Slides are made under rigorous scientific control; the product of long experience combined with the most up to date techniques.
2. Set of overhead transparencies, large size, full colour. Overhead Transparencies clearly show, on the screen, the details of the specimen required for demonstration at the most suitable magnification. The student subsequently finds it easier to locate the relevant part of the microscopic slide under the microscope. The transparencies are printed using a special process and excel by reason of their high projection quality.
3. Set of sketch and worksheets with drawings for all slides. The sketch and worksheets guide the way through the prepared microscope slides and finding the detail important in the lesson. They start processes of learning and understanding by comparing microscope slides with the drawings, thus to identify and label the details relevant in the lesson. They allow completing or colouring the drawings according to own observations, and finally the sheets can be used for tests. Teacher may take photocopies of the sheets for the number of students.
4. Textbook with detailed description of all slides, drawings and transparencies. The Textbooks are intended to help you make more effective use of our teaching material both in the classroom and during individual study. They provide a description of the morphological structures involved, making it considerably easier to look for and find the relevant spots in the microscope slides. They also furnish information regarding systematic and physiological relationships and general biological principles, as well as stimulating classroom interpretation and didactic use of the observations made.
5. Special cardboard box for storing and packing.

The number of student sets should correspond to the number of students in a class. The student sets comprise:

1. Set of selected prepared microscope slides in plastic box (the same as the teacher slides)
2. Textbook with detailed description of all slides
3. Special cardboard box for storing and packing

📖 D/E

Invertebrates
MULTIMEDIA TEACHER PACKAGE

Basic Package of 6 items

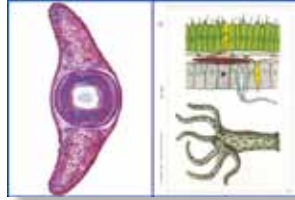
Comprising: 6 Microscope Slides in Plastic Box, 4 OHP Colour Transparencies, 6 Sketch and Worksheets, Brochure with explanatory text, Special cardboard box

1. Marine sponge (*Grantia*), t.s.
2. Hydra, fresh-water polyp, t.s. of body
3. Earthworm (*Lumbricus*), t.s. showing intestine, body wall, muscles
4. Water flea (*Daphnia*), small fresh water crustaceans w.m.
5. Araneus, spider, leg with comb w.m.
6. Starfish (*Asterias*), arm with tube feet, t.s.

9982-1008720
MULTIMEDIA STUDENT SET
Comprising: 6 Microscope Slides in Plastic Box, Brochure with explanatory text, Cardboard box
9982-1008767
Invertebrates
MULTIMEDIA TEACHER PACKAGE

Supplementary Package of 12 items

Comprising: 12 Microscope Slides in Plastic Box, 6 OHP Colour Transparencies, 12 Sketch and Worksheets, Brochure with explanatory text, Special cardboard box

1. Hydra, fresh-water polyp, w.m.
2. Commercial sponge (*Euspongia*), skeleton of horny fibres
3. *Laomedea*, w.m. of colony, vegetative and reproductive polyps
4. Sea Anemone (*Actinia*), t.s. of the body
5. Planaria, t.s. for general structure
6. Tapeworm (*Taenia*), proglottid t.s., intestinal parasite
7. Cyclops sp., copepode, w.m.
8. Crayfish (*Astacus*), intestine, t.s.
9. *Dermanyssus gallinae*, chicken mite, w.m.
10. Clam (*Mya arenaria*), gills, t.s.
11. *chinus*, young sea urchin, t.s.
12. Amphioxus, Branchiostoma, typical t.s. region of gills and intestine.

9982-1008721
MULTIMEDIA STUDENT SET
Comprising: 12 Microscope Slides in Plastic Box, Brochure with explanatory text, Cardboard box
9982-1008768
Insects
MULTIMEDIA TEACHER PACKAGE

Basic Package of 6 items

Comprising: 6 Microscope Slides in Plastic Box, 3 OHP Colour Transparencies, 6 Sketch and Worksheets, Brochure with explanatory text, Special cardboard box

1. *Musca domestica*, housefly, leaking-sucking mouth parts w.m.
2. *Apis mellifica*, honey bee, anterior and posterior wings w.m.
3. *Musca domestica*, house fly, leg with pulvilli w.m.
4. *Pieris*, butterfly, portion of wings with scales w.m.
5. Trachea from insect w.m.
6. Spiracle from insect w.m.

9982-1008722
MULTIMEDIA STUDENT SET
Comprising: 6 Microscope Slides in Plastic Box, Brochure with explanatory text, Cardboard box
9982-1008769
Insects
MULTIMEDIA TEACHER PACKAGE

Supplementary Package of 12 items

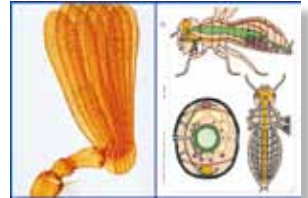
Comprising: 12 Microscope Slides in Plastic Box, 6 OHP Colour Transparencies, 12 Sketch and Worksheets, Brochure with explanatory text, Special cardboard box

1. *Culex pipiens*, mosquito, piercing sucking mouth parts w.m.
2. *Apis mellifica*, honey bee, posterior leg with pollen basket w.m.
3. *Drosophila*, fruit fly, w.m. of adult
4. *Culex pipiens*, mosquito, w.m. of larva
5. *Apis mellifica*, honey bee, mouth parts of worker t.s.
6. *Pieris*, butterfly, clubbed antenna w.m.
7. Aphidae, plant lice adults and larvae w.m.
8. *Pieris*, butterfly, walking leg w.m.
9. *Apis mellifica*, honey bee, sting and poison sac w.m.
10. *Musca domestica*, house fly, wing w.m.
11. *Drosophila*, fruit fly, sagittal l.s. for general insect anatomy
12. *Apis mellifica*, head with compound eyes and brain t.s.

9982-1008723
MULTIMEDIA STUDENT SET
Comprising: 12 Microscope Slides in Plastic Box, Brochure with explanatory text, Cardboard box
9982-1008770
Teaching Series for Elementary Science
MULTIMEDIA TEACHER PACKAGE

Basic Package of 6 items

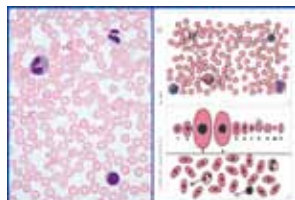
Comprising: 6 Microscope Slides in Plastic Box, 3 OHP Colour Transparencies, 6 Sketch and Worksheets, Brochure with explanatory text, Special cardboard box

1. Letter "e"
2. Leg of house fly w.m.
3. Wing scales of butterfly
4. Human blood smear
5. Large plant cells in the marrow of elderberry t.s.
6. Coloured threads w.m.

9982-1008718
MULTIMEDIA STUDENT SET
Comprising: 6 Microscope Slides in Plastic Box, Brochure with explanatory text, Cardboard box
9982-1008765

Frog Histology (Rana)

MULTIMEDIA TEACHER PACKAGE

Basic Package of 12 items

Comprising: 12 Microscope Slides in Plastic Box, 6 OHP Colour Transparencies, 12 Sketch and Worksheets, Brochure with explanatory text, Special cardboard box.

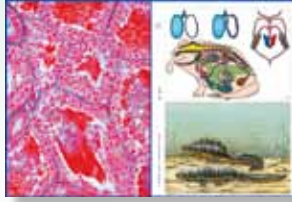

1. Frog, simple sac-like lung t.s.
2. Frog, blood smear, shows nucleated red corpuscles
3. Frog, stomach t.s., glandular epithelium
4. Frog, small intestine t.s., folds
5. Frog, large intestine (colon) t.s., goblet cells
6. Frog, liver t.s., showing liver parenchyma cells-
7. Frog, ovary t.s. shows follicle development, yolk
8. Frog, testis t.s. showing spermatogenesis
9. Frog, heart I.s. of the entire organ
10. Frog, tongue t.s., papillae, glands, muscles
11. Frog, skin t.s., skin glands, epidermis, pigment cells
12. Frog, brain t.s. showing nerve cells.

9982-1008724

MULTIMEDIA STUDENT SET

Comprising: 12 Microscope Slides in Plastic Box, Brochure with explanatory text, Cardboard box

9982-1008771

The Animal Cell (Cytology)

MULTIMEDIA TEACHER PACKAGE

Basic Package of 6 items

Comprising: 6 Microscope Slides in Plastic Box, 3 OHP Colour Transparencies, 6 Sketch and Worksheets, Brochure with explanatory text, Special cardboard box

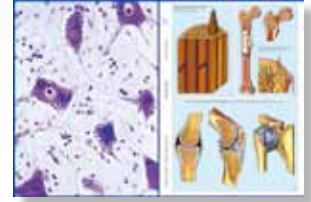

1. Simple animal cells in t.s. of salamander liver
2. Squamous epithelial cells from cheek
3. Nerve cells and fibres
4. Bone cells, t.s. of compact bone
5. Striated muscle cells, I.s. of skeletal muscle
6. Blood cells, smear of human blood with red and white corpuscles.

9982-1008725

MULTIMEDIA STUDENT SET

Comprising: 6 Microscope Slides in Plastic Box, Brochure with explanatory text, Cardboard box

9982-1008772

Human and Animal Histology

MULTIMEDIA TEACHER PACKAGE

Basic Package of 6 items

Comprising: 6 Microscope Slides in Plastic Box, 3 OHP Colour Transparencies, 6 Sketch and Worksheets, Brochure with explanatory text, Special cardboard box

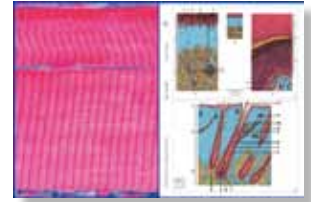

1. Squamous epithelium, isolated cells
2. Hyaline cartilage of calf, t.s
3. Compact bone of cow, t.s.
4. Striated muscles of cat, I.s.
5. Smooth muscles of cat, t.s. and I.s.
6. Blood, human, Giemsa or Wright stained smear.

9982-1008726

MULTIMEDIA STUDENT SET

Comprising: 6 Microscope Slides in Plastic Box, Brochure with explanatory text, Cardboard box

9982-1008773

Human and Animal Histology

MULTIMEDIA TEACHER PACKAGE

Supplementary Package I of 12 items

Comprising: 12 Microscope Slides in Plastic Box, 6 OHP Colour Transparencies, 12 Sketch and Worksheets, Brochure with explanatory text, Special cardboard box

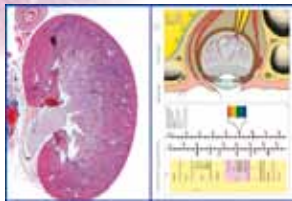

1. Columnar epithelium, human gall bladder, t.s
2. Elastic cartilage, ear, t.s.
3. Elastic tissue stain
4. Skin, human, from palm, t.s. showing sweat glands
5. Lung, human t.s. showing alveoli
6. Heart muscle, t.s. and I.s., striations, intercalated discs
7. Stomach of cat, fundic region, t.s.
8. Kidney, cat, t.s. showing cortex and medulla
9. Testis, rabbit, t.s. showing spermatogenesis
10. Ovary, rabbit, t.s. follicle development
11. Cerebrum, human, cortex, t.s.
12. Spinal cord, cat, t.s. for general structure
13. Tongue, rabbit, t.s., papillae with taste buds.

9982-1008727

MULTIMEDIA STUDENT SET

Comprising: 12 Microscope Slides in Plastic Box, Brochure with explanatory text, Cardboard box

9982-1008774

Human and Animal Histology

MULTIMEDIA TEACHER PACKAGE

Supplementary Package II of 12 items

Comprising: 12 Microscope Slides in Plastic Box, 6 OHP Colour Transparencies, 12 Sketch and Worksheets, Brochure with explanatory text, Special cardboard box

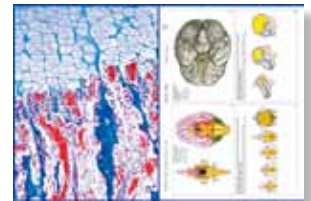

1. Ciliated epithelium, trachea, t.s.
2. Adipose tissue, t.s.
3. Bone development (intracartilaginous), I.s. of foetal finger
4. White fibrous tissue of cow, I.s. of tendon
5. Artery, human, t.s., elastica stained
6. Vein, human, t.s., elastica stained
7. Small intestine of cat, t.s. stained for goblet cells
8. Pancreas, human, t.s. with islets of Langerhans
9. Liver of pig, t.s.
10. Cerebellum, human, t.s.
11. Thyroid gland of cow, t.s
12. Mammary gland of cow, t.s. active stage.

9982-1008728

MULTIMEDIA STUDENT SET

Comprising: 12 Microscope Slides in Plastic Box, Brochure with explanatory text, Cardboard box

9982-1008775

Embryology and Development of Animals

MULTIMEDIA TEACHER PACKAGE

Basic Package of 6 items

Comprising: 6 Microscope Slides in Plastic Box, 3 OHP Colour Transparencies, 6 Sketch and Worksheets, Brochure with explanatory text, Special cardboard box

1. Frog, early tail bud stage, t.s. with neural tube, notochord 2. Frog, young tadpole, t.s. through head 3. Chicken, 36 hour, t.s. with neural tube, differentiation of mesoderm 4. Chicken, 48 hour, t.s. with differentiation of mesoderm and ectoderm 5. Chicken, 3 day, t.s. of head with primordium of brain, eyes and heart 6. Mouse embryo, t.s. of head, development of hairs, brain, etc.

9982-1008734

MULTIMEDIA STUDENT SET

Comprising: 6 Microscope Slides in Plastic Box, Brochure with explanatory text, Cardboard box

9982-1008781

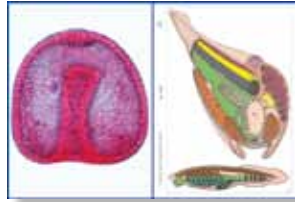

Embryology and Development of Animals

MULTIMEDIA TEACHER PACKAGE

Supplementary Package of 12 items

Comprising: 12 Microscope Slides in Plastic Box, 6 OHP Colour Transparencies, 12 Sketch and Worksheets, Brochure with explanatory text, Special cardboard box

1. Vinegar eels (*Anguillula*), various stages w.m. 2. scaris megaloccephala, first and second maturation divisions in oocytes 3. *Ascaris*, oocytes with male and female pronuclei 4. Mosquito (*Culex*), larva of insect, w.m. 5. Frog, hatching stage, t.s. region of midbody 6. Frog, young tadpole, t.s. thorax 7. Frog, young tadpole, t.s. of abdomen 8. Chicken, 3 day, t.s. through body showing amnion and serosa. 9. Chicken, 4-5 day, t.s. through region of heart shows heart, lungs, vertebrae, spinal cord 10. Chicken, feather development, sec. of wings 11. Mouse embryo, t.s. of body 12. Pig embryo, 11-12 mm, typical t.s. region of abdomen.

9982-1008735

MULTIMEDIA STUDENT SET

Comprising: 12 Microscope Slides in Plastic Box, Brochure with explanatory text, Cardboard box

9982-1008782

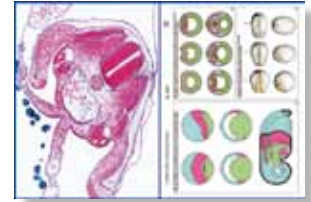

Protozoa

MULTIMEDIA TEACHER PACKAGE

Basic Package of 8 items

Comprising: 8 Microscope Slides in Plastic Box, 4 OHP Colour Transparencies, 8 Sketch and Worksheets, Brochure with explanatory text, Special cardboard box

1. Amoeba proteus, showing nucleus and pseudopodia 2. Paramecium, a ciliate found in hay infusions 3. Euglena, a common green flagellate 4. Ceratium, dinoflagellates 5. Vorticella, a stalked ciliate. 6. Radiolaria, different forms 7. Monocystis, sporozoa in earthworm seminal vesicle 8. Trypanosoma, blood flagellate causing sleeping sickness, blood smear.

9982-1008719

MULTIMEDIA STUDENT SET

Comprising: 8 Microscope Slides in Plastic Box, Brochure with explanatory text, Cardboard box

9982-1008766

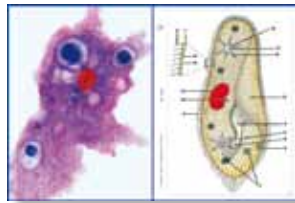

Human Diseases (Pathology)

MULTIMEDIA TEACHER PACKAGE

Basic Package of 6 items

Comprising: 6 Microscope Slides in Plastic Box, 3 OHP Colour Transparencies, 6 Sketch and Worksheets, Brochure with explanatory text, Special cardboard box.

1. Tuberculosis of the lung, t.s. with bacterial foci 2. Anthracosis of lung (smokers' lung) 3. Struma of thyroid gland (Goiter) 4. Acute haemorrhagic nephritis (Kidney) 5. Cirrhosis of liver, t.s. (abuse of alcohol) 6. Eberthella typhi (typhoid fever), smear.

9982-1008729

MULTIMEDIA STUDENT SET

Comprising: 6 Microscope Slides in Plastic Box, Brochure with explanatory text, Cardboard box

9982-1008776

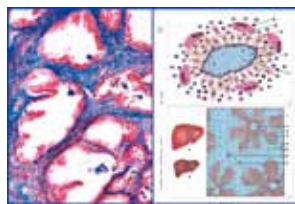

Human Diseases (Pathology)

MULTIMEDIA TEACHER PACKAGE

Supplementary Package of 12 items

Comprising: 12 Microscope Slides in Plastic Box, 6 OHP Colour Transparencies, 12 Sketch and Worksheets, Brochure with explanatory text, Special cardboard box

1. Miliary tuberculosis of liver 2. Influenzal pneumonia 3. Spindle cell sarcoma 4. Carcinoma of liver (primary) 5. Hypertrophy of prostate 6. Adiposis of heart 7. Icterus hepatis 8. Myoma of uterus 9. Carcinoma of uterus 10. Malaria parasites in blood (Plasmodium), smear 11. Sleeping disease of humans, blood smear with flagellates (*Trypanosoma*) 12. Pus bacteria, smear showing cocci in irregular balls.

9982-1008730

MULTIMEDIA STUDENT SET

Comprising: 12 Microscope Slides in Plastic Box, Brochure with explanatory text, Cardboard box

9982-1008777

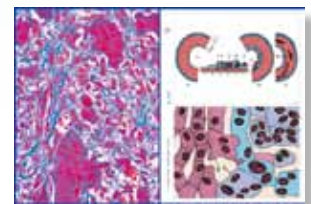

**Parasites of Man and Animals
MULTIMEDIA TEACHER PACKAGE**

Basic Package of 6 items

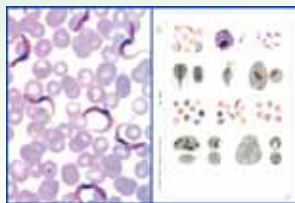
Comprising: 6 Microscope Slides in Plastic Box, 3 OHP Colour Transparencies, 6 Sketch and Worksheets, Brochure with explanatory text, Special cardboard box

1. Trypanosoma, blood flagellate causing sleeping sickness, blood smear
2. Plasmodium falciparum, causing malaria tropica, human blood smear
3. aenia, tapeworm, proglottids in different stages t.s
4. scaris lumbricoides, roundworm of human, adult female t.s. in region of gonads.
5. Trichinella spiralis, t.s. of infected muscle with larvae
6. Fasciola hepatica, beef liver fluke, t.s. of the body.

9982-1008731**MULTIMEDIA STUDENT SET****Comprising: 6 Microscope Slides in Plastic Box, Brochure with explanatory text, Cardboard box****9982-1008778****Parasites of Man and Animals
MULTIMEDIA TEACHER PACKAGE**

Supplementary Package of 12 items

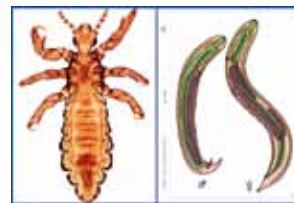
Comprising: 12 Microscope Slides in Plastic Box, 6 OHP Colour Transparencies, 12 Sketch and Worksheets, Brochure with explanatory text, Special cardboard box

1. Entamoeba histolytica, smear or section
2. iveria stiedae, coccidiosis in rabbit liver, t.s.
3. Monocystis, from earthworm seminal vesicle
4. Fasciola hepatica, beef liver fluke, w.m.
5. Taenia pisiformis, tapeworm, mature proglottids w.m.
6. Enterobius vermicularis (Oxyuris), pin worm, w.m.
7. Echinococcus granulosus, dog tapeworm, cyst wall and scolices sec.
8. Dermanyssus, chicken mite w.m.
9. Anopheles, malaria mosquito, mouth parts of female w.m.
10. Culex pipiens, common mosquito, mouth parts of female w.m.
11. Pediculus humanus, human louse, w.m.
12. Ctenocephalus canis, dog flea, adult w.m.

9982-1008732**MULTIMEDIA STUDENT SET****Comprising: 12 Microscope Slides in Plastic Box, Brochure with explanatory text, Cardboard box****9982-1008779****Algae****MULTIMEDIA TEACHER PACKAGE**

Basic Package of 6 items

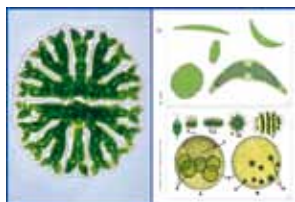
Comprising: 6 Microscope Slides in Plastic Box, 3 OHP Colour Transparencies, 6 Sketch and Worksheets, Brochure with explanatory text, Special cardboard box

1. Nostoc, blue-green alga with heterocysts
2. Diatoms, fresh water, recent, mixed species
3. Spirogyra, vegetative filaments with spiral chloroplasts, w.m.
4. Cladophora sp., branching filaments with multinucleate cells
5. Chlamydomonas, biflagellate cells, w.m.
6. Desmids, strewn slide showing several selected forms.

9982-1008741**MULTIMEDIA STUDENT SET****Comprising: 6 Microscope Slides in Plastic Box, Brochure with explanatory text, Cardboard box****9982-1008788****Algae****MULTIMEDIA TEACHER PACKAGE**

Supplementary Package of 12 items

Comprising: 12 Microscope Slides in Plastic Box, 6 OHP Colour Transparencies, 12 Sketch and Worksheets, Brochure with explanatory text, Special cardboard box

1. Chroococcus, a single-cell alga, w.m
2. Oscillatoria, a blue-green filamentous alga w.m.
3. Microcystis, irregular colonies w.m.
4. Draparnaldia, main filaments and clusters of branches w.m.
5. Hydrodictyon, water net, w.m.
6. Oedogonium, a filamentous green alga with vegetative and sexual stages
7. Volvox, spherical colonies with daughter colonies and sexual stages w.m.
8. Dinobryon, a golden alga forming colonies w.m.
9. Pleurococcus (Proto-coccus), small colonies growing on bark, w.m.
10. Laminaria saccharina, thallus with sporangia, c.t.
11. Fucus vesiculosus, seaweed, male conceptacle with antheridia, t.s.
12. Fucus vesiculosus, female conceptacle with oogonia t.s.

9982-1008742**MULTIMEDIA STUDENT SET****Comprising: 12 Microscope Slides in Plastic Box, Brochure with explanatory text, Cardboard box****9982-1008789****Mitosis and Meiosis (Cell division)****MULTIMEDIA TEACHER PACKAGE**

Basic Package of 6 items

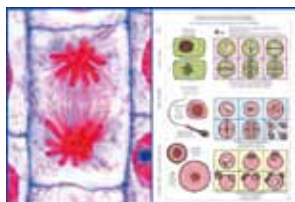
Comprising: 6 Microscope Slides in Plastic Box, 3 OHP Colour Transparencies, 6 Sketch and Worksheets, Brochure with explanatory text, Special cardboard box

1. Allium, root tips, l.s. showing lateral view of all stages of mitosis, iron-hematoxyline
2. Whitefish mitosis, l.s. of embryo showing animal mitosis
3. Testis of mouse, t.s. showing spermatogenesis in all stages
4. Giant chromosomes from salivary gland of Chironomus, squash preparation special stained for chromomeres
5. Liliun, microspore mother cells, prophase of first division showing meiosis
6. Liliun, microspore mother cells, meta- or anaphase of first division, showing mitosis.

9982-1008738**MULTIMEDIA STUDENT SET****Comprising: 6 Microscope Slides in Plastic Box, Brochure with explanatory text, Cardboard box****9982-1008785****Reproduction of Animals****MULTIMEDIA TEACHER PACKAGE**

Basic Package of 6 items

Comprising: 6 Microscope Slides in Plastic Box, 3 OHP Colour Transparencies, 6 Sketch and Worksheets, Brochure with explanatory text, Special cardboard box

1. Mitotic (division) stages in red bone marrow of mammal t.s.
2. Meiotic (maturation) stages in testis of mouse t.s.
3. Sea-urchin development, first cleavage stages of egg cells, w.m.
4. Growing egg and yolk cells in ovary of bird, t.s.
5. Ovary of rabbit or other mammal showing oogenesis, t.s.
6. Sperm smear of bull showing w.m. of spermatozoa.

9982-1008733**MULTIMEDIA STUDENT SET****Comprising: 6 Microscope Slides in Plastic Box, Brochure with explanatory text, Cardboard box****9982-1008780**

Genetic Slides

MULTIMEDIA TEACHER PACKAGE

Basic Package of 6 items

Comprising: 6 Microscope Slides in Plastic Box, 3 OHP Colour Transparencies, 6 Sketch and Worksheets, Brochure with explanatory text, Special cardboard box

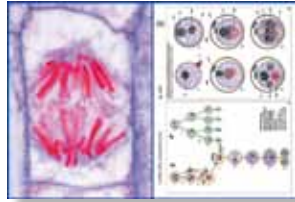

1. Allium cepa, onion, root tips, I.s. showing all stages of mitosis
2. Chromosomes, human, culture of peripheral blood, smear preparation
3. Sea urchin, developing of eggs, w.m. of most stages up to pluteus in the same slide
4. Ascaris megalcephala, male and female pronuclei, sec.
5. Testis of rabbit, t.s. showing spermatogenesis in all stages
6. Spirogyra, scalariform conjugation showing zygotes following conjugation.

9982-1008736

MULTIMEDIA STUDENT SET

Comprising: 6 Microscope Slides in Plastic Box, Brochure with explanatory text, Cardboard box

9982-1008783

Genetic Slides

MULTIMEDIA TEACHER PACKAGE

Supplementary Package of 12 items

Comprising: 12 Microscope Slides in Plastic Box, 6 OHP Colour Transparencies, 12 Sketch and Worksheets, Brochure with explanatory text, Special cardboard box



1. Allium, root tips, t.s. showing polar view of mitosis, iron-hematoxyline
2. Ovary of rabbit, I.s. follicles in various stages of development
3. Lilium, microspore mother cells, prophase stages t.s.
4. aramaecium, from mass culture showing stages of binary division
5. hizopus or Mucor, mold, formation of zygosporos w.m.
6. Mmium, moss, archegonium, I.s.
7. Mmium, moss, antheridium, I.s.
8. inus, young female cone at time of pollination, I.s.
9. Pinus, male cone with pollen I.s.
10. Lilium, stigma, I.s. showing penetrating pollen grains
11. Drosophila genetics, adult wild type, w.m.
12. Drosophila genetics, "barr eye" mutant, w.m.

9982-1008737

MULTIMEDIA STUDENT SET

Comprising: 12 Microscope Slides in Plastic Box, Brochure with explanatory text, Cardboard box

9982-1008784

Bacteria

MULTIMEDIA TEACHER PACKAGE

Basic Package of 6 items

Comprising: 6 Microscope Slides in Plastic Box, 3 OHP Colour Transparencies, 6 Sketch and Worksheets, Brochure with explanatory text, Special cardboard box

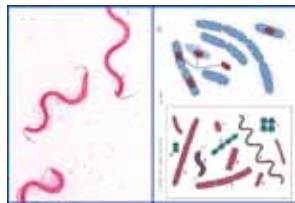

1. Bacteria from mouth, smear with Gram positive and negative rods
2. Typical bacteria: three smears on one slide, cocci, bacteria and spirilli are shown, carefully stained
3. Staphylococcus aureus, pus organism
4. Bacillus subtilis, hay bacillus, smear with bacilli and spores
5. Escherichia coli, colon bacteria
6. Spirillum volutans, large species from putrid water.

9982-1008739

MULTIMEDIA STUDENT SET

Comprising: 6 Microscope Slides in Plastic Box, Brochure with explanatory text, Cardboard box

9982-1008786

Bacteria

MULTIMEDIA TEACHER PACKAGE

Supplementary Package of 12 items

Comprising: 12 Microscope Slides in Plastic Box, 6 OHP Colour Transparencies, 12 Sketch and Worksheets, Brochure with explanatory text, Special cardboard box

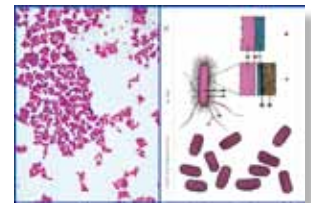

1. Streptococcus pyogenes, pus organism
2. Sarcina lutea, chromogenic rods occurring in packets
3. Streptococcus lactis, milk souring organism, short chains
4. Mycobacterium tuberculosis, causing tuberculosis
5. Corynebacterium diphtheriae, causing diphtheria
6. Rhizobium radicola, nitrogen fixing bacteria in root nodules
7. Proteus vulgaris, putrefaction
8. Eberthella typhi, causing typhoid fever
9. Clostridium botulinum (botulism), causing food poisoning, smear
10. Acetobacter aceti, manufacture of vinegar, smear
11. Salmonella enteritidis, causes meat poisoning, smear
12. Rhodospirillum rubrum, chromogenic spirilli.

9982-1008740

MULTIMEDIA STUDENT SET

Comprising: 12 Microscope Slides in Plastic Box, Brochure with explanatory text, Cardboard box

9982-1008787

The Plant Cell (Cytology)

MULTIMEDIA TEACHER PACKAGE

Basic Package of 6 items

Comprising: 6 Microscope Slides in Plastic Box, 3 OHP Colour Transparencies, 6 Sketch and Worksheets, Brochure with explanatory text, Special cardboard box

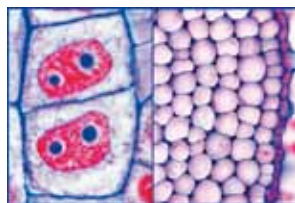

1. Epidermis of Allium cepa (onion), w.m. showing simple plant cells with cell walls, nuclei and cytoplasm
2. Fruit of Pyrus (pear) t.s. showing stone cells (sclerenchyma cells)
3. Tuber of Solanum (potato) t.s. shows cork and starch grains
4. Cucurbita pepo (pumpkin) I.s. of stem showing vascular bundles with sieve tubes, spiral and annular vessels, sclerenchyma fibres
5. Anthers of Lilium (lily), t.s. showing pollen sacs and pollen grains
6. Ovary of Lilium (lily), t.s. showing arrangement of ovules and embryosac.

9982-1008745

MULTIMEDIA STUDENT SET

Comprising: 6 Microscope Slides in Plastic Box, Brochure with explanatory text, Cardboard box

9982-1008792

Typical Leaves of Phanerogams

MULTIMEDIA TEACHER PACKAGE

Basic Package of 6 items

Comprising: 6 Microscope Slides in Plastic Box, 3 OHP Colour Transparencies, 6 Sketch and Worksheets, Brochure with explanatory text, Special cardboard box

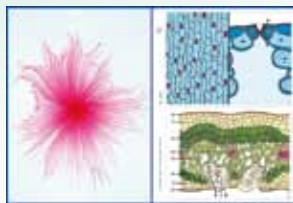

1. Zea mays, corn, monocot gramineous leaf t.s. 2. Syringa, lilac, t.s. of a typical mesophytic dicot leaf for general study 3. Tulipa, tulip, leaf epidermis w.m., showing stomata and guard cells 4. Elodea, t.s. of leaf showing the simple structure of an aquatic leaf 5. Nerium, oleander, leaf with sunken stomata t.s., showing the typical structures of a xerophytic leaf 6. Pinus, leaves (needles), t.s. for general study of gymnosperm leaves.

9982-1008750

MULTIMEDIA STUDENT SET

Comprising: 6 Microscope Slides in Plastic Box, Brochure with explanatory text, Cardboard box

9982-1008797

Typical Leaves of Phanerogams

MULTIMEDIA TEACHER PACKAGE

Supplementary Package of 12 items

Comprising: 12 Microscope Slides in Plastic Box, 6 OHP Colour Transparencies, 12 Sketch and Worksheets, Brochure with explanatory text, Special cardboard box

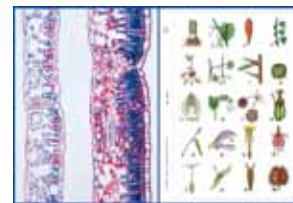

1. Iris, typical isobilateral leaf t.s. 2. Poa annua, meadow grass, leaf t.s. 3. Ligustrum, privet, t.s. of dicot leaf 4. Helleborus, t.s. of a typical mesophytic dicot leaf for general study 5. Ficus elastica, India rubber plant, leaf with cystoliths t.s. 6. Nymphaea, water lily, floating leaf of an aquatic plant with air chambers t.s. 7. Potamogeton, pondweed, leaf t.s. 8. Calluna, ling, revolute leaves t.s. 9. Verbascum, mullein, branched leaf hairs w.m. 10. Dionaea, Venus flytrap, t.s. of leaf with digestive glands 11. rosera, sundew, leaf with glandular hairs, t.s. 12. Fagus, beech, leaf bud t.s. showing leaf development.

9982-1008751

MULTIMEDIA STUDENT SET

Comprising: 12 Microscope Slides in Plastic Box, Brochure with explanatory text, Cardboard box

9982-1008798

Typical Roots of Phanerogams

MULTIMEDIA TEACHER PACKAGE

Basic Package of 6 items

Comprising: 6 Microscope Slides in Plastic Box, 3 OHP Colour Transparencies, 6 Sketch and Worksheets, Brochure with explanatory text, Special cardboard box

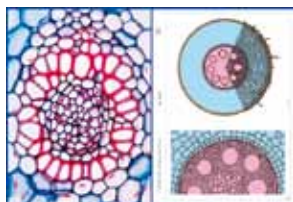

1. Zea mays, corn, typical monocot root t.s. 2. Ranunculus, buttercup, typical dicot root t.s. 3. Root tip and root hairs, t.s. to show epidermal origin of root hairs 4. Smilax, carrion flower, t.s. of root shows thickened endodermis 5. Elodea, Canadian waterweed, t.s. of an aquatic root 6. Lupinus, root nodules with nitrogen fixing bacteria (Rhizobium radicicola) t.s.

9982-1008746

MULTIMEDIA STUDENT SET

Comprising: 6 Microscope Slides in Plastic Box, Brochure with explanatory text, Cardboard box

9982-1008793

Typical Roots of Phanerogams

MULTIMEDIA TEACHER PACKAGE

Supplementary Package of 12 items

Comprising: 12 Microscope Slides in Plastic Box, 6 OHP Colour Transparencies, 12 Sketch and Worksheets, Brochure with explanatory text, Special cardboard box

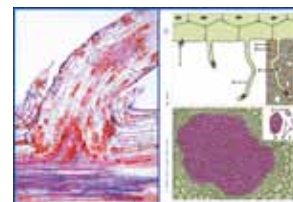

1. Herbaceous and woody roots, two t.s. on one slide 2. Young (primary) and older (secondary) roots, two t.s. on one slide 3. Salix, willow, l.s. of root showing origin of lateral roots 4. Iris, typical monocot root t.s. 5. Medicago, alfalfa, root t.s. showing secondary growth 6. Tilia, lime, older woody root t.s. 7. Monstera, aerial root t.s. 8. Taraxacum, dandelion, taproot with lactiferous vessels t.s. 9. Fagus, beech, root with ectotrophic mycorrhiza, t.s. 10. Neottia nidus avis, orchid, root with endotrophic mycorrhiza, l.s. 11. Cuscuta, dodder, t.s. through stem of host showing the haustoria of the parasite 12. Pinus, older woody root t.s.

9982-1008747

MULTIMEDIA STUDENT SET

Comprising: 12 Microscope Slides in Plastic Box, Brochure with explanatory text, Cardboard box

9982-1008794

Varieties of Wood

MULTIMEDIA TEACHER PACKAGE

Basic Package of 6 items

Comprising: 6 Microscope Slides in Plastic Box, 3 OHP Colour Transparencies, 6 Sketch and Worksheets, Brochure with explanatory text, Special cardboard box



1. Maple. Acer platanoides, three sections of wood 2. Beech. Fagus silvatica, three sections of wood 3. Pine. Pinus silvestris, three sections of wood 4. Spruce. Picea excelsa, three sections of wood 5. Poplar. Populus alba, three sections of wood 6. Lime. Tilia platyphylla, three sections of wood.

9982-1008754

MULTIMEDIA STUDENT SET

Comprising: 6 Microscope Slides in Plastic Box, Brochure with explanatory text, Cardboard box

9982-1008801



Typical Stems of Phanerogams

MULTIMEDIA TEACHER PACKAGE

Basic Package of 6 items

Comprising: 6 Microscope Slides in Plastic Box, 3 OHP Colour Transparencies, 6 Sketch and Worksheets, Brochure with explanatory text, Special cardboard box

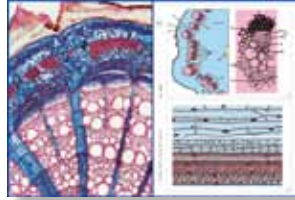

1. Zea mays, typical monocot stem with scattered bundles, t.s., a standard slide for general study 2. Helianthus, sunflower, typical dicot herbaceous stem t.s. showing open vascular bundles 3. Cucurbita, pumpkin, l.s. of stem with sieve tubes and vascular bundles 4. Triticum, wheat, t.s. through the stem of a gramineous plant 5. Elodea, waterweed, t.s. of aquatic stem showing primitive bundle 6. onvallaria, lily of the valley, t.s. of rhizome with concentric vascular bundles.

9982-1008748

MULTIMEDIA STUDENT SET

Comprising: 6 Microscope Slides in Plastic Box, Brochure with explanatory text, Cardboard box

9982-1008795

Flowers and Fruits

MULTIMEDIA TEACHER PACKAGE

Basic Package of 6 items

Comprising: 6 Microscope Slides in Plastic Box, 3 OHP Colour Transparencies, 6 Sketch and Worksheets, Brochure with explanatory text, Special cardboard box

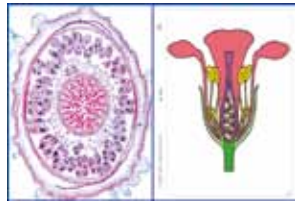

1. Liliun candidum, lily, t.s. of flower bud showing floral diagram of a monocot 2. Lycopersicum, tomato, t.s. of flower bud shows floral diagram of a dicot 3. Liliun, anther t.s. showing pollen chambers and pollen grains 4. Liliun, ovary t.s., showing arrangement of ovules 5. Capsella bursa pastoris, shepherd's purse, l.s. of ovule with embryos 6. Triticum, wheat, grain (seed), t.s. showing embryo and endosperm.

9982-1008752

MULTIMEDIA STUDENT SET

Comprising: 6 Microscope Slides in Plastic Box, Brochure with explanatory text, Cardboard box

9982-1008799

Textile Fibres, Hairs and Furs

MULTIMEDIA TEACHER PACKAGE

Basic Package of 6 items

Comprising: 6 Microscope Slides in Plastic Box, 3 OHP Colour Transparencies, 6 Sketch and Worksheets, Brochure with explanatory text, Special cardboard box



1. Merino wool 2. Cocoon silk, raw 3. Linen (flax) 4. American cotton 5. Cellulose fibres 6. Nylon fabric.

9982-1008755

MULTIMEDIA STUDENT SET

Comprising: 6 Microscope Slides in Plastic Box, Brochure with explanatory text, Cardboard box

9982-1008802

Typical Stems of Phanerogams

MULTIMEDIA TEACHER PACKAGE

Supplementary Package of 12 items

Comprising: 12 Microscope Slides in Plastic Box, 6 OHP Colour Transparencies, 12 Sketch and Worksheets, Brochure with explanatory text, Special cardboard box

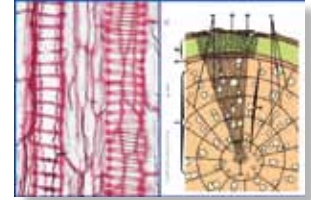

1. Aristolochia, one year stem t.s. for general study 2. Aristolochia, older stem t.s. 3. Fagus, beech, three sections of wood: t.s., r.l.s., t.l.s. 4. Tilia, lime, older woody stem with annual rings, t.s. 5. Nymphaea, water lily, aquatic stem with idioblasts t.s. 6. Potamogeton, pondweed, stem with aerial chambers t.s. 7. Opuntia, cactus, succulent stem t.s. 8. Ranunculus, buttercup, t.s. stem with open vascular bundles 9. Coleus, t.s. of a square stem showing collenchyma clearly 10. Hedera helix, ivy, stem with crystals t.s. 11. Clematis, young hexagonal stem t.s., collenchyma 12. Solanum tuberosum, potato, t.s. of tuber with starch grains.

9982-1008749

MULTIMEDIA STUDENT SET

Comprising: 12 Microscope Slides in Plastic Box, Brochure with explanatory text, Cardboard box

9982-1008796

Flowers and Fruits

MULTIMEDIA TEACHER PACKAGE

Supplementary Package of 12 items

Comprising: 12 Microscope Slides in Plastic Box, 6 OHP Colour Transparencies, 12 Sketch and Worksheets, Brochure with explanatory text, Special cardboard box

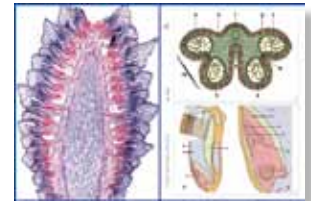

1. Liliun, l.s. of stigma with pollen and pollen tubes 2. Monotropa, Indian pipe, ovary t.s. with developing embryosacs 3. Papaver, poppy, t.s. of flower shows parietal placentation 4. Solanum tuberosum, potato, t.s. flower bud for floral diagram 5. Taraxacum, dandelion, l.s. of composite flower 6. Cocos nucifera, coconut, endosperm t.s. 7. Citrus, lemon, young fruit t.s. 8. Lycopersicum, tomato, young fruit t.s. 9. Pyrus malus, apple, young pome t.s., a fleshy, many seeded fruit 10. Mixed pollen types, many different species 11. Pinus, ovule l.s. showing archegonia, for general study 12. Pinus, male cone with pollen l.s.

9982-1008753

MULTIMEDIA STUDENT SET

Comprising: 12 Microscope Slides in Plastic Box, Brochure with explanatory text, Cardboard box

9982-1008800

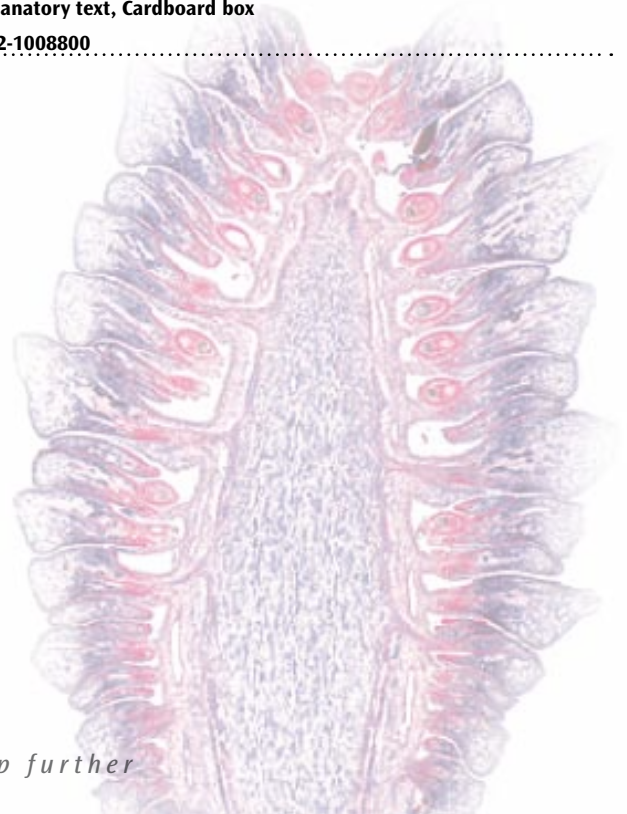

Cryptogams

MULTIMEDIA TEACHER PACKAGE

Basic Package of 12 items

Comprising: 12 Microscope Slides in Plastic Box, 6 OHP Colour Transparencies, 12 Sketch and Worksheets, Brochure with explanatory text, Special cardboard box

1. Oscillatoria, blue green alga
2. Spirogyra sp., vegetative filaments w.m.
3. Mucor, black mold, mycelium and sporangia
4. Peziza, apothecium with asci t.s.
5. Saccharomyces, yeast, budding cells
6. Coprinus, mushroom, t.s. showing typical basidia and spores
7. Moss stem with leaves w.m.
8. Marchantia, liverwort, archegonia l.s.
9. Marchantia, liverwort, antheridia l.s.
10. Equisetum, horsetail, strobilus with spores l.s.
11. Pteridium, bracken fern, t.s. of rhizome
12. Aspidium (Dryopteris), fern, leaflet with sporangia and spores t.s.

9982-1008743

MULTIMEDIA STUDENT SET

Comprising: 12 Microscope Slides in Plastic Box, Brochure with explanatory text, Cardboard box

9982-1008790



Cryptogams

MULTIMEDIA TEACHER PACKAGE

Supplementary Package of 12 items

Comprising: 12 Microscope Slides in Plastic Box, 6 OHP Colour Transparencies, 12 Sketch and Worksheets, Brochure with explanatory text, Special cardboard box

1. Nostoc, blue green alga with heterocysts
2. Diatoms, mixed species
3. Albugo candida, white rust of crucifers, t.s.
4. Penicillium, blue mold, mycelium and conidiophores
5. Puccinia graminis, wheat rust, uredinia on wheat t.s.
6. Psalliotia, gill fungus, pileus with lamellae t.s.
7. Claviceps purpurea, ergot, stroma with perithecia l.s.
8. Physcia, sec. through thallus of a typical lichen showing the fungus and the embedded algae
9. Polytrichum, moss, capsule with spores t.s.
10. Equisetum, horse tail, spores with elaters w.m.
11. Lycopodium, clubmoss, sporophyll with spores l.s.
12. Fern prothallium w.m.

9982-1008744

MULTIMEDIA STUDENT SET

Comprising: 12 Microscope Slides in Plastic Box, Brochure with explanatory text, Cardboard box

9982-1008791



The Wonderful World in a Drop of Water

MULTIMEDIA TEACHER PACKAGE

Basic Package of 6 items

Comprising: 6 Microscope Slides in Plastic Box, 3 OHP Colour Transparencies, 6 Sketch and Worksheets, Brochure with explanatory text, Special cardboard box

1. Euglena, green flagellate with eyespot
2. Paramecium, nuclei stained
3. Daphnia and Cyclops, small crustaceans
4. Spirogyra, green alga with spiral chloroplasts
5. Spongilla, fresh water sponge, isolated spicules
6. Diatoms, diatoms, mixed species.

9982-1008758

MULTIMEDIA STUDENT SET

Comprising: 6 Microscope Slides in Plastic Box, Brochure with explanatory text, Cardboard box

9982-1008805

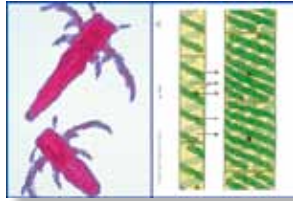

The Wonderful World in a Drop of Water

MULTIMEDIA TEACHER PACKAGE

Supplementary Package of 12 items

Comprising: 12 Microscope Slides in Plastic Box, 6 OHP Colour Transparencies, 12 Sketch and Worksheets, Brochure with explanatory text, Special cardboard box

1. Ceratium hirundinella, dinoflagellates
2. Vorticella, a stalked ciliate
3. Putrefaction causing bacteria from hay infusions
4. Hydra, fresh water polyp, t.s. of the body
5. Cladophora, green alga, branched filaments
6. Eudorina, small colonies within gelatinous sheaths
7. Microcystis, irregular colonies
8. rotatoria, rotifers, mixed species
9. Planaria, fresh water flat worm, t.s. of body
10. Plumatella, moss animal, section of colony
11. Tubifex, a fresh water oligochaete
12. Mixed plankton, strewn slide.

9982-1008759

MULTIMEDIA STUDENT SET

Comprising: 12 Microscope Slides in Plastic Box, Brochure with explanatory text, Cardboard box

9982-1008806

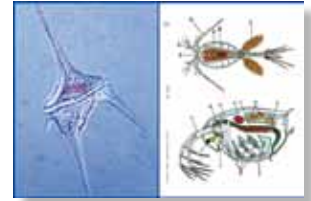

Spoiled Foodstuffs

MULTIMEDIA TEACHER PACKAGE

Basic Package of 6 items

Comprising: 6 Microscope Slides in Plastic Box, 3 OHP Colour Transparencies, 6 Sketch and Worksheets, Brochure with explanatory text, Special cardboard box

1. Mold in spoiled foodstuffs
2. Sour milk, stained for bacteria
3. Wheat flour adulterated with chalk
4. Corn flour spoiled with spores of corn smut (Ustilago)
5. Rye flour spoiled with moths
6. Flour spoiled with mites (Tyroglyphus farinae).

9982-1008756

MULTIMEDIA STUDENT SET

Comprising: 6 Microscope Slides in Plastic Box, Brochure with explanatory text, Cardboard box

9982-1008803

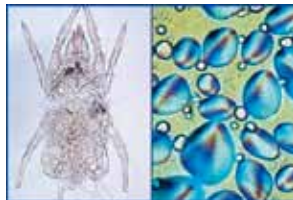

Foodstuffs and Spices under the Microscope

MULTIMEDIA TEACHER PACKAGE

Basic Package of 12 items

Comprising: 12 Microscope Slides in Plastic Box, 6 OHP Colour Transparencies, 12 Sketch and Worksheets, Brochure with explanatory text, Special cardboard box

1. Rye flour
2. Potato starch
3. Soya meal
4. Wheat flour
5. Rice starch
6. Coffee bean t.s.
7. Black pepper, ground
8. Paprika, ground
9. Nutmeg t.s.
10. Cocoa powder
11. Tobacco, leaves t.s.
12. Hazelnut, t.s. stained for fat.

9982-1008757

MULTIMEDIA STUDENT SET

Comprising: 12 Microscope Slides in Plastic Box, Brochure with explanatory text, Cardboard box

9982-1008804

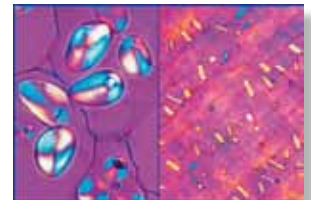

**Anatomy of Phanerogams
MULTIMEDIA TEACHER PACKAGE**

Basic Package of 12 items
Comprising: 12 Microscope Slides in Plastic Box, 6 HP Colour Transparencies, 12 Sketch and Worksheets, Brochure with explanatory text, Special cardboard box

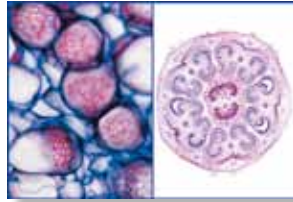

1. Zea mays, corn, monocot root t.s.
2. Ranunculus, buttercup, dicot root t.s.
3. Root tip and root hairs, t.s. epidermal origin of root hairs
4. Zea mays, monocot stem with scattered bundles, t.s.
5. Helianthus, sunflower, dicot herbaceous stem t.s.
6. Zea mays, corn, monocot gramineous leaf t.s.
7. Syringa, lilac, t.s. of a typical mesophytic dicot leaf
8. Tulipa, tulip, leaf epidermis w.m., stomata and guard cells
9. Liliium, lily, t.s. of flower bud showing floral diagram
10. Liliium, anther t.s. showing pollen chambers and pollen grains
11. Liliium, ovary t.s., showing arrangement of ovules
12. riticum, wheat, seed t.s. embryo and endosperm.

9982-1008763

MULTIMEDIA STUDENT SET

Comprising: 12 Microscope Slides in Plastic Box, Brochure with explanatory text, Cardboard box

9982-1008810

**Anatomy of Phanerogams
MULTIMEDIA TEACHER PACKAGE**

Supplementary Package of 12 items
Comprising: 12 Microscope Slides in Plastic Box, 6 OHP Colour Transparencies, 12 Sketch and Worksheets, Brochure with explanatory text, Special cardboard box

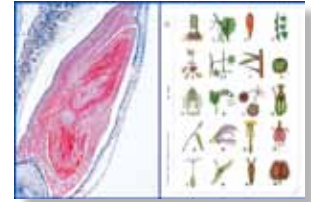

1. Herbaceous and woody roots, two t.s. on one slide
2. Lupinus, root nodules with nitrogen fixing bacteria t.s.
3. Fagus, beech, root with ectotrophic mycorrhiza, t.s.
4. Aristolochia, older stem t.s.
5. Cucurbita, pumpkin, l.s. of stem with sieve tubes and vascular bundles
6. Solanum tuberosum, potato, t.s. of tuber with starch grains
7. Nerium, oleander, leaf with sunken stomata t.s. xerophytic leaf
8. Pinus, leaves (needles), t.s.
9. Lycopersicum, tomato, t.s. of flower bud shows floral diagram
10. Mixed pollen types, many different species
11. Pinus, ovule l.s. showing archegonia
12. Pinus, male cone with pollen l.s.

9982-1008764

MULTIMEDIA STUDENT SET

Comprising: 12 Microscope Slides in Plastic Box, Brochure with explanatory text, Cardboard box

9982-1008811

Identifying Polluted Water under the Microscope

MULTIMEDIA TEACHER PACKAGE
Basic Package of 6 items

Comprising: 6 Microscope Slides in Plastic Box, 3 OHP Colour Transparencies, 6 Sketch and Worksheets, Brochure with explanatory text, Special cardboard box

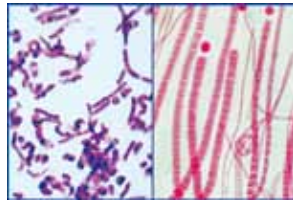

1. Intestinal bacteria (Escherichia coli) from putrid water
2. Putrefactive bacteria (Spirillum) from sludge poor in oxygen
3. Sludge bacteria (Methanobacterium) causing sewer gas
4. Cyanobacteria (Microcystis), blue-green algae "blooming" in stagnant water
5. Ciliates, different species from nutrient rich water
6. Water mold (Saprolegnia), harmful to plants and animals.

9982-1008760

MULTIMEDIA STUDENT SET

Comprising: 6 Microscope Slides in Plastic Box, Brochure with explanatory text, Cardboard box

9982-1008807

Animals and Plants Damaged by Environmental Influences

MULTIMEDIA TEACHER PACKAGE
Basic Package of 8 items

Comprising: 8 Microscope Slides in Plastic Box, 4 OHP Colour Transparencies, 8 Sketch and Worksheets, Brochure with explanatory text, Special cardboard box

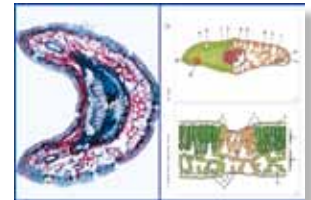

1. Skin of fish injured by chemicals, t.s.
2. Skin ulcer of an amphibian, t.s.
3. Human lung injured with dust particles, t.s.
4. Gall nut on oak caused by insects, t.s.
5. Beech (Fagus), t.s. of leaves with destroyed epidermis and chloroplasts
6. Damaged lichen, caused by air pollution
7. Wood with anomalous narrow annual rings caused by drought, t.s.
8. Wood destroyed by fungus.

9982-1008762

MULTIMEDIA STUDENT SET

Comprising: 8 Microscope Slides in Plastic Box, Brochure with explanatory text, Cardboard box

9982-1008809

Air Pollution and Allergens

MULTIMEDIA TEACHER PACKAGE
Basic Package of 6 items

Comprising: 6 Microscope Slides in Plastic Box, 3 OHP Colour Transparencies, 6 Sketch and Worksheets, Brochure with explanatory text, Special cardboard box

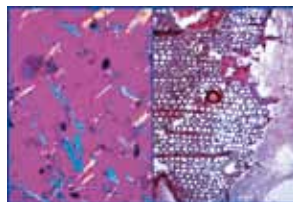

1. Pollen grains of different kinds of grass
2. Pollen grains of different kinds of conifers
3. Mixed house dust (causing allergens)
4. Asbestos powder (carcinogenic)
5. Dust mite from a living room
6. Spores of different fungi.

9982-1008761

MULTIMEDIA STUDENT SET

Comprising: 6 Microscope Slides in Plastic Box, Brochure with explanatory text, Cardboard box

9982-1008808



9982-1005962

Student Dissecting Kit

Excellent value for your classroom! Ideal for both junior and secondary school students. Complete set of instruments includes tools for routine dissection labs.

Kit includes:

- Ruler 15 cm
- Screw-lock blade scalpel
- Scalpel blade
- Dropping pipette
- Student scissors
- Straight teasing needle
- Curved teasing needle
- Medium point forceps
- Leatherette case

7.6x17 cm; 0.1 kg

9982-1005962



9982-1005964

Biology Dissecting Kit

Includes the stainless steel and chrome instruments presented in a deluxe, single-fold, lined vinyl case. Kit includes:

- Ruler 15 cm
- Dissecting knife handle
- Scalpel blades
- Dropping pipette
- Straight operating scissors 14 cm
- Seeker probe
- Straight teasing needle
- Medium point forceps
- Leatherette case

7.6x17 cm; 0.15 kg

9982-1005964



9982-1005321

Preparation Set

This set is supplied in a stackable transparent plastic box and consists of:

- Needle in holder, straight (2 pieces)
- Forceps, fine, 130 mm
- Microscopical scissors, straight
- Scalpel handle No. 4
- Set of 5 scalpel blades, slightly curved

9982-1005321

Dissecting Instruments

This first-rate dissecting set contains top quality stainless steel instruments in an attractive vinyl case.

- 1 pair of scissors, pointed, 10 cm
- 1 pair of forceps, pointed, 13 cm
- 1 dissecting needle, 13.5 cm
- 1 scalpel blade holder n° 4
- 5 replacement scalpel blades n° 11

9982-1008710

Dissecting Set

Deluxe dissecting set fit for a skilled instructor. Encased in an attractive vinyl case lined with velvet, the kit includes the following high quality stainless steel tools:

- 1 fine scissors, sharp tip, 11.5 cm
- 1 large scissors, 1 sharp tip, 1 blunt tip, 13.5 cm
- 1 fine forceps, serrated, sharp tip, 12 cm
- 1 large forceps, serrated, blunt tip, 13 cm
- 1 one-piece scalpel, 4 cm blade
- 1 straight needle, 13 cm
- 1 lancet needle, 15 cm
- 1 Dumont forceps, 11 cm
- 1 scalpel handle, 14 cm
- 5 scalpel blades, 6 cm

9982-1003771



9982-1003771

9982-1008710

Large Dissecting Kit

Kit includes:

- Ruler 15 cm
- Dissecting knife handle
- Curved scalpel blades
- Full convex blades
- Section lifter
- Curved dissection scissors 12 cm
- Straight operating scissors 14 cm
- Hemostatic forceps 12.5 cm
- Hemostatic forceps 16.5 cm
- Seeker probe
- Straight teasing needle
- Curved teasing needle
- Dressing forceps 12 cm
- Dressing forceps 13 cm
- Retraction hook
- Leatherette case

9982-1005965

9982-1005965



9982-1005081

 9982-1005082 /
9982-1005083

9982-1008919

 9982-1005080 /
9982-1005081

**Microscope Slides, cut edges
cellophane wrapped**

 Approx. 76x26x1 mm
50 pcs/box

9982-1005082

**Microscope slides, ground
edges**

 90°, cellophane wrapped
Approx. 76x26x1 mm
50 pcs/box

9982-1005083

Cover Glasses, non-ground

 18x18 mm, No. 1 (0.13–0.16 mm
thickness), Ar-glass, for manual
use not suitable for automated
processes.
200 pcs/tropical packing (vacuum
sealed)

9982-1005080

Cover Glasses, non-ground

 18x18 mm, No. 1 (0.13 – 0.16 mm
thickness), borosilicate glass, also
suitable for automated processes
(cover slipper).
200 pcs/ box

9982-1005081

**Microscope slides with one
cavity**

 Ground edges, 76x26x1.2 mm
50 pcs/box

9982-1008919



9982-1005968



9982-1005967



9982-1008921

**Pasteur pipettes, dropping
pipettes**

 3 ml, Polyethylene, nonsterile.
500 pcs/box

9982-1008933

Slide storage map

For 20 slides, cardboard, with cover

9982-1008921

Slide Box for 25 Slides, Green

 Durable plastic storage box
141x88x35 mm; 0.16 kg

9982-1005968

Slide Box for 50 Slides, Blue

209x86x35mm; 0.2 kg

9982-1005967

**Pasteur pipettes, dropping
pipettes**

 1 ml, Polyethylene, nonsterile.
500 pcs/box

9982-1008934

9982-1008934

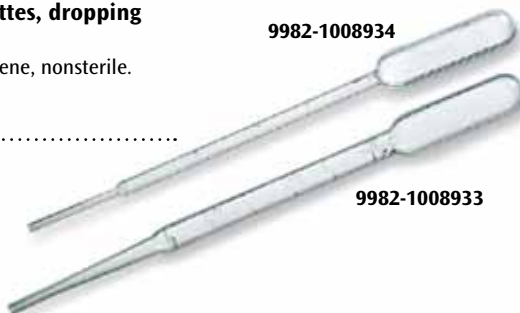

9982-1008933

Schiefferdecker staining dish

 For 20 slides 76x26 mm
(back to back), with cover.
Approx. 45x85x70 mm

9982-1005967



9982-1008920



9982-1005076

9982-1008928

9982-1008929

9982-1008930

9982-1008922

9982-1008923

9982-1008924

Soft Tweezers

At last soft stainless steel tweezers, ideal for students to examine objects without damaging them. Length approx. 10 cm

9982-1005076

Anatomical Forceps

Stainless steel, blunt, 14.5 cm

9982-1008929

Microscope Scissors

Stainless steel, 11.5 cm

9982-1008922

Scissors

Stainless steel, straight, pointed/pointed, 14.5 cm

9982-1008924

Anatomical Forceps

Stainless steel, pointed, 14.5 cm

9982-1008928

Forceps for Cover-Glasses

Stainless steel, curved, 11.5 cm

9982-1008930

Scissors

Stainless steel, straight, extremely pointed, 12 cm

9982-1008923



9982-1008925

9982-1008926

9982-1008927

9982-1008931

Probe

Approx. 160x2 mm

9982-1008925

Dissection Needle

Plastic-handle, pointed

9982-1008926

Scalpel Handle no. 3

Stainless steel

9982-1008931

Dissection Needle

Plastic-handle, with blade

9982-1008927



9982-1008932

Scalpel Blades, Size 10

Single packed, sterile, carbon steel.

100 pcs/box

9982-1008932



9982-1002873



9982-1002872



9982-1013360 – 9982-1013363

NEW



9982-1002870

9982-1010114

Graduated Cylinder, 250 ml

Graduated cylinder made of borosilicate glass. Tall form with spout and hexagonal base.

Scale: 250 ml

Divisions: 2.5 ml

9982-1010114

Graduated Cylinder, 100 ml

Graduated cylinder made of Duran glass. Tall form with spout with hexagonal base.

Scale: 100 ml

Divisions: 1 ml

9982-1002870

Beakers, 600 ml

Set of 10 beakers made of Borosilicate glass.

With scale, 100 ml divisions and spout.

9982-1002872 Set of 10 Beakers, low form

9982-1002873 Set of 10 Beakers, tall form

Measuring Cylinders, PP

Tall, moulded scale, class B per DIN 12681/ISO 6706, translucent,

ring-moulded graduations, hexagonal base, food-safe

Delivery contents: 12 items/box

9982-1013360 Measuring Cylinder, 50 ml, hexagonal base

9982-1013361 Measuring Cylinder, 100 ml, hexagonal base

9982-1013362 Measuring Cylinder, 250 ml, pentagon base

9982-1013363 Measuring Cylinder, 500 ml, pentagon base

9982-1013424–9982-1013424



NEW

9982-1013416



Measuring Pipettes

Class B, brown graduation, AR glass, according to DIN standards, full evacuation, 0 at top, graded right to the tip, colour code according to ISO standards, from 5 ml with cotton plug attachment
Delivery contents: 12 items/box

- 9982-1013407 Measuring Pipette, 1 ml in 1/100
- 9982-1013408 Measuring Pipette, 2 ml in 1/100
- 9982-1013409 Measuring Pipette, 5 ml in 1/100
- 9982-1013410 Measuring Pipette, 10 ml in 1/100

Microlitre Pipettes with Variable Volume

Using this microlitre pipette, your pupils can work with precision. The pipettes have a volume display that can be set easily and accurately, they also have an inbuilt pipette tip ejector system. What is more, they fit well in the hand, and offer an excellent price-performance ratio.

- 9982-1013416 Microlitre Pipette, 0.5 – 10 µl
- 9982-1013418 Microlitre Pipette, 10 – 100 µl
- 9982-1013420 Microlitre Pipette, 20 – 200 µl
- 9982-1013421 Microlitre Pipette, 100 – 1000 µl

Options and Replacement Parts for Microlitre Pipettes

- 9982-1013424 Pipette tips, crystal, Eppendorf, up to 10 µl, natural, 1,000 items/bag
- 9982-1013425 Pipette tips, yellow, Eppendorf (20 - 200 µl) 1,000 items/bag
- 9982-1013426 Pipette tips, blue, Eppendorf, (up to 1,000 µl), 1,000 items/bag
- 9982-1013427 Rack, for Eppendorf tips, PP, with press-on lid, empty
- 9982-1013428 5 Insets for rack, Eppendorf, with 96 pipette tips for each inset, crystal, up to 10 µl
- 9982-1013429 5 Insets for rack, Eppendorf, with 96 pipette tips for each inset, yellow, 20 to 200 µl
- 9982-1013430 5 Insets for rack, Eppendorf, with 96 pipette tips for each inset, blue, up to 1,000 µl

NEW

9982-1011800



Mortar and Pestle

Made of laboratory porcelain, Mortar: rough, Ø 113 mm, 150 ml; Pestle: friction surface rough. 110 mm long
9982-1011800

9982-1013392



Peleus Ball, Standard

High quality production (made in Germany) and therefore long-lasting 15x6x7 cm, 0.05 kg
9982-1013392

NEW

9982-1012540

9982-1012541



9982-1012538



Petri Dishes

Without vents, approx. 55x15 mm, PS, crystal clear, packed machine sterile, 15 pcs/bag
9982-1012538

Petri Dishes

Without vents, approx. 94x16 mm, PS, crystal clear, packed machine sterile, 20 pcs/bag
9982-1012540

Petri Dishes

With vents, approx. 94x16 mm, 2-parts, PS, crystal clear, packed machine sterile, 20 pcs/bag
9982-1012541



9982-1001051

Set of 8 Test Tubes

Set of 8 Test Tubes, 16 mm dia.
9982-1001051



9982-1008682 / 9982-1009812

Washing Bottle, PP, 250 ml

9982-1008682

Washing Bottle, PP, 500 ml

9982-1009812

Laboratory Coat

A robust laboratory coat suitable for use in both schools and laboratories. It comes with:

- 1/1 Arm
- Stand-up collar
- Covered stud buttons
- 1 breast pocket
- 2 side pockets
- A rear slit

Made of a classical mix of robust cotton / polyester mix (Öko-Tex Standard 100). Capable of withstanding even the demands of an industrial laundry, it is colour fast and easy to clean.

Washing and care tips:



The laboratory coat is available in the following sizes:

9982-1012620	Laboratory Coat, size S
9982-1012621	Laboratory Coat, size M
9982-1012622	Laboratory Coat, size L
9982-1012623	Laboratory Coat, size XL

Lab Coat for Children and Adolescents

Young students are often not as careful as they could be when doing their first experiments. Our lab coat made of cotton has a breast pocket and two side pockets. It protects your student's clothes and makes them look like professional scientists!

Size 158 (smaller sizes available on request)

9982-1012410



9982-1012620 – 9982-1012623

9982-1012410

Student Safety Glasses

Proper safety glasses for students!

The shape and size of these safety glasses are specifically designed for students between 10 and 15. With excellent side protection and a perfect fit thanks to easily adjustable arms. The safety glasses are very light and comfortable to wear. DIN EN 166 compliant. With blue frame and all-round scratch-resistant polycarbonate protection.

13x6x4.5 cm

D/E/F/I/S

9982-1003798



9982-1003798



9982-1010257

Protective Goggles

These snug-fitting protective goggles that comply with DIN EN 166 F have adjustable sidearms and can therefore be adjusted for different head shapes. The mist-proof polycarbonate lenses offer good visibility and effective lateral protection.

0.15x0.06x0.06 cm; 0.04 kg

9982-1010257



9982-1005077 – 9982-1005079

Vinyl Gloves

Powdered disposable vinyl gloves – great skin protection and good tolerance.

Contents: 100 pieces in a practical dispenser carton

9982-1005077	Vinyl Gloves, size S
9982-1005078	Vinyl Gloves, size M
9982-1005079	Vinyl Gloves, size L

Magnetic Stirrer with Heater

Magnetic stirrer with stainless steel hotplate and secure safety circuit. Variable heating temperature and smooth starting stirrer motor. Housing resistant to chemicals.
 Quantity stirred, max. (H₂O): 10 l
 Speed: 100 – 2000 rpm
 Heater power: 400 W
 Heating temperature range: Room temperature to 320 °C
 Work plate: 125 mm diam.
 Dimensions: 168x105x220 mm³ approx.
 Weight: 2.4 kg approx.



NEW

9982-1002807
9982-1002806



9982-1002808

Magnetic Stirrer with Heater (230 V, 50/60 Hz)

9982-1002807

Magnetic Stirrer with Heater (115 V, 50/60 Hz)

9982-1002806



9982-1005881

9982-1005882

EdvoCycler™ PCR Machine

Polymerase Chain Reaction (PCR) is one of the most exciting techniques in modern biology and now you can do it in your classroom! PCR copies a very small sample amount of DNA so it can be analyzed. The process won the Nobel Prize in 1993 and is widely used in forensics, medical testing and genetics research. It uses repeated heating and cooling in the presence of the enzyme DNA polymerase to copy a piece of DNA (the template). The exact region copied is determined by short stretches of DNA called primers. The ability to make lots of copies quickly of a particular region of DNA makes PCR a very useful technique in modern biology. The EdvoCycler is a specially designed classroom PCR machine that is easy to use. Your students can amplify DNA from a variety of sources, including from a single hair, with one of our PCR kits. The EdvoCycler is pre-programmed with PCR protocols and these are simply selected using the screen. A PCR run takes about 1 or 2 hours (or can be done overnight) and the samples are then visualized using DNA electrophoresis.

Features:

- Holds 25x 0.2ml tubes
- Heated lid with magnetic catch
- Pre-programmed with all Edvotek PCR kit protocols
- Clear LCD display with live programme information
- Easy to use

41x22x18 cm

D/E/F/S/I

9982-1005882

Magnetic Stirrer

Ultra flat magnetic stirrer with non wearing drive featuring no moving parts. With feature for changing direction of stirring automatically every 30 seconds for improved homogenization. Work plate and housing resistant to chemicals, non slip and secure base. Including plug in power supply.
 Quantity stirred, max. (H₂O): 0.8 l
 Speed: 15 – 1500 rpm
 Work plate: 100 mm diam.
 Power supply: power supply unit 100 V – 240 V
 Dimensions: 114x12x161 mm³ approx.
 Weight: 0.3 kg approx.

9982-1002808

A Well Specified Digital Waterbath at an Economical Price!

An excellent waterbath for many classroom experiments. The stainless steel chamber is corrosion resistant and temperature controlled from ambient to 95°C with cover. There is a low water sensor and the waterbath is deep enough to accommodate manumerously bottles and flasks.

Features:

- Chamber Dimensions (WxDxH): 15x14x10 cm
- Low water sensor
- Digital display
- Temperature range: ambient to 95 °C with cover

D/E/F/S/I

9982-1005881



9982-1005880

Piccolo Centrifuge™

Our small and economical microcentrifuge is suitable for many classroom applications. These include: quickly spinning down samples and for mixing solutions during DNA electrophoresis and PCR experiments.

Features:

- Maximum speed 6,000 rpm/2,000x g
- Safety on/off switch
- Starts and stops in seconds
- Capacity for 6x 1.5/2.0 ml tubes
- Dimensions (WxDxH) 15x15x12 cm

D/E

9982-1005880

• Simple
• Fast
• Cost-effective



9982-1012852

NEW

Electrophoresis Chamber

- Excellent value for money is just one of the advantages of our high-quality electrophoresis chamber. The following features speak for themselves:
- Electrophoresis takes places easily using fluorescent dyes thanks to the UV-transparent bottom, by placing the chamber on a UV plate.
 - The gel can be poured on relatively thinly (3-4 mm). This means first of all a high level of sensitivity with non-toxic DNA dyeing. It also means that less gel is used!
 - The buffer volume is sufficient but not excessive, therefore there is less need for chemicals.
 - With the ideal gel size of 10x10 cm, with two comb positions, 2 rows of 12 samples can be separated parallel to each other.
 - The gel is poured directly onto the bottom of the chamber, doing away with the need for a separate gel pouring stand.
 - The chamber is made of high quality Plexiglas that is very resistant to UV light and the effects of chemicals. Your chamber will still look good after years of use.
 - Of course, the chamber is equipped with security plugs, high quality electrodes (evaporation deposition with gold) and platinum wire (99.9%).

Contents:

Electrophoresis chamber, safety plug with integrated power connections, comb with 12 pockets
21x11x3.4 cm

9982-1010262



9982-1010263

Excellent price-performance ratio

Electrophoresis Network Device

You can use this stabilised network device for both DNA and protein separation. It is highly effective and easy to operate. Of particular note are the adjustable output voltage and the timer with alarm function. The device has two outputs so that you can connect two electrophoresis chambers.

- Max. output voltage: 300 Volt (in 50 Volt stages)
- Max. output current: 400mA
- Max. power consumption: 60 Watt
- Input voltage: 100 – 240 Volt AC
- Timer function: 1 – 999 min. with alarm function

9982-1010263

Dual DNA Electrophoresis LabStation™

This set contains all you need for any classroom DNA electrophoresis experiment! The DNA electrophoresis tanks are durable and injection-moulded horizontal units designed for ease of use and safety. Included with the unit are two 6-Tooth combs and a double 8/10-Tooth comb allowing separation of up to 16 samples simultaneously. The 7x14 cm gel casting tray has an embossing gel ruler and includes innovative rubber end caps which seal the tray making gel casting easier than ever! Both the electrophoresis chamber and the gel casting tray are UV transparent. The Dual Power Source (70/125 V) is designed for DNA or protein electrophoresis. The unit generates DC power of 70 or 125 volts with a maximum current of 250 mA. It is equipped with an easily replaceable slow burn fuse and is CE approved. The variable micropipettes are sturdily designed with volumes ranging from 5 to 50µl. They are very precise and use standard disposable micropipette tips. They are simple to use. A tool and instructions are included for self-calibration.

Supplied with:

2 Horizontal Electrophoresis Apparatus (one 7x14 cm gel tray in each), 1 Dual Power Source (70/125 V for 1 or 2 units) and 2 Variable Micropipettes (5 – 50 µl).

36x36x25 cm; 4 kg

D/E

9982-1005878



9982-1005878

Electrophoresis experiments are to be found on Pages 134/135

Specific Benefits:

- **Flexible Power:**
Use either the included AC adapter, or 4 "AA" batteries to power your Scout Pro.
- **Easy to Clean:**
Sealed front panel and moulded spill ring.
- **Easy to View:**
High contrast LCD quickly displays weight and applications data, as well as indicators for stability, over/underload conditions, and low battery power.



9982-1003431

9982-1009772, 9982-1003426
9982-1003428, 9982-1003427

Scales



9982-1003429, 9982-1012774

Round or Square Stainless Steel Platform
Removable for easy cleaning.



Electronic Scales with Stainless Steel Hood

This robust electronic balance combines functionality with great design. It offers the following advantages:

- Effective seal so that no fluids can enter the scales
- Practical, easy-to-clean stainless steel surface
- Flexible placement due to battery operation
- Auto-switch off for minimum power and battery consumption

Technical Data:

Capacity: 5.000 g / 11 lbs
 Graduation: 1 g < 3,000 g > 2 g / 0.05 oz < 6.6 lbs > 0.1 oz
 Weight: 1.5 kg / 4.2 lbs
 Power supply: Batteries
 Functions: Automatic switch-off, Pre-TARE, TARE, HOLD, kg/lbs switch-over
 Material: Cover: stainless steel, base: black plastic material
 Dimensions (WxHxD): 266x53x266 mm

9982-1005380



9982-1005380

Electronic Scales Scout Pro

Precision scales with removable stainless steel platform. Multi-function with percentage weighing, totalisation, display hold, and parts counting. Includes calibrating weight.

	9982-1009772/ 9982-1003426	9982-1003428/ 9982-1003427	9982-1003429/ 9982-1012774
Weight range	0 – 200.00 g	0 – 400.00 g	0 – 600.0 g
Accuracy	0.01 g	0.01 g	0.1 g
Display	LCD, 6 digits, 15 mm		
Weight ranges	g, N, oz, %	g, N, oz, %	g, kg, N, oz, lb, %
Calibration	Automatic using external weight		
Scale pan	120 mm diam.	120 mm diam.	165x140 mm
Dimensions	approx. 192x54x210 mm ³		
Weight	approx. 700 g	approx. 700 g	approx. 800 g

Other weight ranges available on request.

Electronic Scale Pro 200 g
(230 V, 50/60 Hz)

9982-1009772

Electronic Scale Pro 200 g
(115 V, 50/60 Hz)

9982-1003426

Electronic Scale Pro 400 g
(230 V, 50/60 Hz)

9982-1003428

Electronic Scale Pro 400 g
(115 V, 50/60 Hz)

9982-1003427

Electronic Scale Pro 600 g
(230 V, 50/60 Hz)

9982-1003429

Electronic Scale Pro 600 g
(115 V, 50/60 Hz)

9982-1012774

Accessories:

USB Interface

For connecting Scout Pro to a printer or PC.

9982-1003431

Instrumentation

NEW

Scales



9982-1012881

ABS Analytical Scales (230 V, 50/60 Hz)

Precision analytical scales with automatic adjustment mechanism and high resolution. Tough metal casing with glass windscreen, large graphic display and RS232 port. The scales offer practically every function needed in laboratories:

- Counting items
- Percentage weights
- Switching between different units
- Capacity display for weight range
- GLP/ISO protocols
- Programmable 4-digit ID number
- CAL adjustment program for setting accuracy

Max. measuring range: 220 g
 Precision: 0.1 mg
 Reproducibility: 0.1 mg
 Linearity: ± 0.2 mg
 Time to settle: 3 – 5 s approx.
 Item counting
 Minimum weight: 1 mg
 References: 10, 20, 50, 100
 Weight display: LCD, 13 mm
 Weighing platform: 80 mm diam.
 Power supply: 12 V DC power supply, mains voltage 230 V, 50/60 Hz
 Dimensions: 225x315x330 mm³
 Weight: 7 kg

9982-1012881

BEST SELLER

9982-1003433
9982-1003434



Electronic Scales

Universal scales in robust plastic casing, with easy-clean foil keyboard. Menu functions, easy selection using two buttons. High-resolution, easy to read LCD display, overload and underload display, battery or mains operation optional. Automatic shutdown after five minutes in battery operation. Batteries included.

	9982-1003433	9982-1003434
Scale range	0 – 200.0 g	0 – 5000 g
Accuracy	0.1 g	1 g
Weight units	g, lb:oz	g, lb:oz
Counter-balancing range	subtractive, entire weight range	subtractive, entire weight range
Power supply	3 AA alkaline batteries	3 AA alkaline batteries
Dimensions	approx. 193x135x39 mm ³	approx. 193x135x39 mm ³
Weight	approx. 470 g	approx. 470 g

Overhead Projector

Reliable overhead projector in modern moulded plastic housing with collapsible reflector column. High quality optical system with correction to avoid coloured edges and highly efficient low noise cooling.

Lamp: 36 V, 400 W
 Light flux: 2200 lumens
 Aperture: 285x285 mm² approx.
 Dimensions of housing: 450x440x320 mm³ approx.
 Weight: 9 kg approx.

Overhead Projector (230 V, 50/60 Hz)

9982-1003264

Overhead Projector (115 V, 50/60 Hz)

9982-1003263



Replacement Bulb for Overhead Projector

(not shown)

Replacement bulb for overhead projector, 36 V, 400 W.

9982-1003265

Instrumentation

9982-1003264
9982-1003263

Art. No.	Description	Measuring Range	Scale Division	Dimensions	Remarks
9982-1002881	Pocket Thermometer	-10° – 110 °C	1 °C	165 mm x 10 mm dia.	Tube type, scale on white background, petroleum based red filling, in yellow plastic protective case with clip.
9982-1002879	Tube Thermometer, Graduated	-10° – 110 °C	1 °C	260 mm x 6 mm dia.	Glass thermometer with eyelet, scale on white background, petroleum based red filling, in transparent square plastic case.
9982-1003384	Thermometer	-20° – 110 °C	1 °C	295 mm x 6,3 mm dia.	Tube type with anti-roll design, white coated capillary, red alcohol filling, packed in a plastic tube.
9982-1003014	Demonstration Thermometer	-10° – 110 °C	1 °C	650 mm x 30 mm dia.	Extra-large tube type thermometer with biodegradable special blue filling, easy to read scale on yellow background.

Digital Quick Response Pocket Thermometer

For instantaneous measurements on surfaces, in liquids, soft plastic media, air/gases, very small objects. For connection to a K-type NiCr-Ni measurement sensor. Sensor not included in scope of supply.

Measuring range: -65 °C – 1150 °C / -85 °F – 1999 °F in 2 ranges
 Division: 0.1 °C / 1 °C/F
 Accuracy in lowest range: 0,05% of measured value ±0,2% FS
 Display: 3½-digit LCD display, 13 mm in height
 Dimensions: 106x67x30 mm³
 Mass: approx. 135 g

9982-1002803

Additionally required:

K-Type NiCr-Ni Immersion Sensor, -65 °C to 550 °C

9982-1002804

or

K-Type NiCr-Ni Immersion Sensor, -200 °C to 1150 °C

9982-1002805

9982-1002881 9982-1002879 9982-1003384 9982-1003014



9982-1002803



9982-1002878



9982-1003010

Maximum-Minimum Thermometer

Reading of maximum, minimum and instantaneous temperature. In plastic housing with reset button and hanging strap. Mercury filling.

Measuring range: -38 °C – 50 °C
 Divisions: 1 °C
 Dimensions: approx. 230x85 mm²

9982-1002803

Digital Thermometer, Min/Max

Insertion thermometer with Hold and Min/Max function in robust plastic housing and temperature sensor made of stainless steel. Switchable between °C and °F, On/Off switch, hanging strap and folding angled support.

Measuring range: -50 °C – 200 °C / -58 °F – 392 °F
 Division: 0.1 °C/F
 Dimensions: 95x65x20 mm³
 Cable length: 1400 mm
 Measurement probe: 120 mm

9982-1003010



9982-1002809

Table-Top Stop-Clock

Large quartz-controlled stop-clock with start stop and reset buttons, cumulative time and lap-time settings (clock resets to zero and starts timing again immediately). 2 hands, dial with dual scale for minutes/seconds and hundredths of a minute.

Measuring range: 60 min / 60 s
 Graduations: 1 s / 1/100 min
 Dial: 110 mm dia.
 Dimensions: approx. 175x130x95 mm³

9982-1002809



9982-1003009

Digital Stopwatch

Stopwatch with 7-digit LCD display in robust plastic casing with start/stop and split/reset buttons for starting and stopping, cumulative, lap-time and dual-time measurement. Includes pendant cord.

Measuring range: 9 h, 59 min, 59 s, 99/100 s
 Accuracy: 1/100 s
 Battery: watch battery 1.55 V, Type 389
 Dimensions: approx. 65x65x18 mm³

9982-1002811



9982-1002811

Timer

Stopwatch for counting up or down with acoustic alarm. Magnetic holder for attachment to metal surfaces and fold-away support legs.

Display: 4-digit display, LCD, 18 mm
 Timer range: 99 min 59 s
 Ticking rate: 1 s
 Dimensions: ca. 60x60x20 mm³

9982-1003009

NEW



9982-1002779

Digital Luxmeter

Extremely reasonably priced, easy to use pocket luxmeter for testing and measurement of light conditions. C.I.E. standard spectrum.

Including light sensor, pouch and battery
 Measuring ranges: 200 – 50000 lux, 4 ranges, ±5%
 Operating voltage: Battery
 Dimensions: approx. 65x115x25 mm³
 Weight: approx. 160 g

9982-1002779



9982-1002780

Noise Level Meter P8005

Digital noise level meter with circuit for suppressing background noise for measuring all types of sound levels in the environment, including noise levels in schools, offices, factories, traffic noise, household noise or for noise reduction projects. Allows for manual or automatic selection of levels and measurements of minimum and maximum levels. Thanks to its built in USB port, the supplied 9 V mains adapter and stand, it is also suitable for permanent or long term measurement. Includes case, USB cable, Windows software, stand, 9 V mains adapter, 9 V battery and instruction manual.

Digital display: 4 digit LCD
 Height of digits: 20 mm
 Multi-functions display: 58x44 mm²
 Digital display of measurement, measuring time, bar graphs plus overs and unders
 Background lighting: blue
 Applicable standards: IEC-61672-1 type 2, ANSI S1.4 type 2
 Frequency range: 31.5 Hz – 8 kHz
 Dynamic range: 50 dB
 Level ranges: 30 – 80 dB (low)
 50 – 100 dB (medium)
 80 – 130 dB (high)
 30 – 130 dB (automatic)

Resolution: 0.1 dB
 Precision: ±1.4 dB
 Response times: 125 ms (fast), 1s (slow)
 Microphone: ½-inch, with electret capacitor
 Display update: Twice a second
 Analogue output: AC/DC
 Operating voltage: 9 V battery or 9 V mains adapter
 Dimensions: 90x280x50 mm³ approx.
 Weight: 350 g approx.

9982-1002780



9982-1013076

NEW

Rain gauge

This transparent, conical container is made of a totally synthetic material, and has a stand so that the rain gauge can be placed on a pole in the open air.

Graduation up to 40 mm/m²
 Height: 205 mm x Ø 85 mm
 Weight: 170 g

9982-1013076



9982-1002877

Precision Hair Hygrometer

Hygrometer for measuring the relative air humidity, consisting of a round plastic housing with a human hair as the measuring element. The specially treated hair exhibits an almost inertia free response to changes in humidity. Wall mountable.

Measuring range: 0% – 100% relative humidity
 Temperature range: - 35 °C – + 65 °C
 Reading accuracy: ± 5%
 Diameter: 100 mm

9982-1002877



9982-1002627

Demonstration Aneroid Barometer

Barometer for measuring air pressure and demonstrating how an aneroid barometer operates. The measurement system consists of two flat, highly-evacuated metal cans which deform in response to changes in the air pressure. This deformation is indicated by a pointer. The pointer mechanism and metal cans are situated behind a glass cover for easy observation. By pumping the attached rubber ball the action caused by the air pressure changes can be demonstrated.

Measuring ranges: 955 mbar up to 1070 mbar, scale division 1 mbar
 715 mmHg up to 800 mmHg, scale division 1 mmHg
 Scale diameter: 120 mm
 Housing diameter: 130 mm
 Weight: 650 g

9982-1002627

Weather

NEW



9982-1010248

Wireless Weather Station

Weather station with wireless detection of external temperatures from up to three sensors situated at distances of up to 25 m. Display of internal temperature and humidity. Features switchable °C/°F display, min/max function, weather forecasting, trend displays for air pressure and radio-controlled clock with date function. Supplied with one external temperature sensor, two 1.5-V AA batteries and two 1.5-V AAA batteries. Silver/grey housing. Can be suspended or set up on a surface.

External temperatures: -30°C ... +70°C
 Internal temperatures: 0°C ... +60°C
 Humidity: 1 ... 99%

9982-1010248

NEW



9982-1010250

Digital Pocket Anemometer

Waterproof anemometer for measuring wind speed. Indication of wind chill temperature based on the combination of air temperature and wind speed. Indication of mean and maximum speeds. Wind curves on the Beaufort scale. Supplied with closeable cover.

Wind speed: 0,2 ... 30 m/s
 Accuracy: ±5% of mean wind speed
 Units: km/h, m/h, m/s or knots
 Temperature: -30° to +59°C
 Battery: 3.0 V (CR2032)
 Dimensions: 137x50x18 mm³

9982-1010250

Measuring Instruments

3B NETlab™:

- Comprehensive range of data processing functions, including tangents, integration, curve matching, all kinds of formula calculations and interpolation.
- Data acquisition with date and time of each measurement.
- Recording and processing several series of measurements.
- Presentation of data in the form of graphs or tables, analogue or digital multimeter functions.
- Easy configuration of sensor and experiments on the basis of predefined experiment files.
- Text windows for comments about the experiment.
- Support for analogue and digital sensors.
- Automatic identification of sensors.

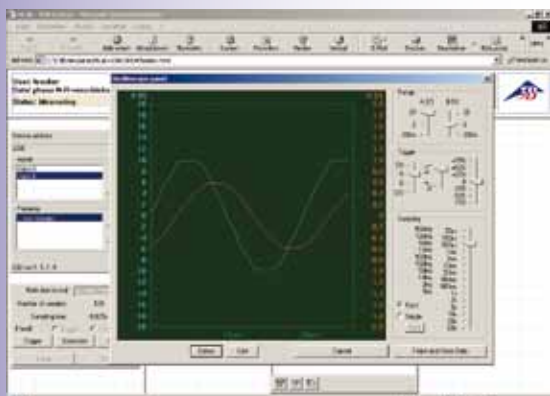

Oscilloscope: Voltage phase shift in RL series resonant circuit

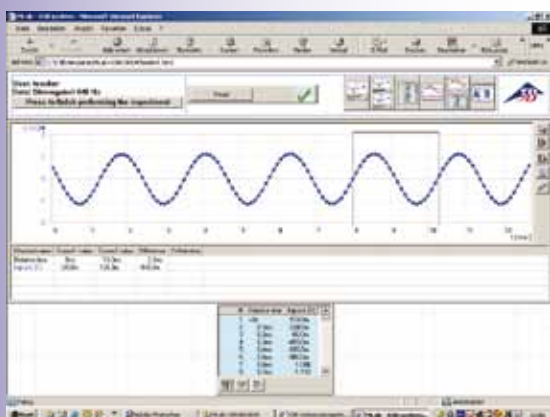

Sound amplitude of a tuning fork as a function of time

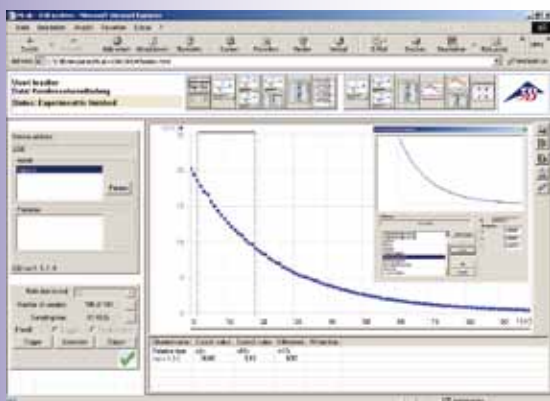

Discharge curve of a capacitor

3B NETlab™

3B NETlab™ is a data acquisition and data processing program for the 3B NETlog™ interface that can also be operated in a network. As it is based on ActiveX technology, all the available functions can be integrated into web pages that can be displayed and used with the Microsoft Internet Explorer browser. The main function of 3B NETlab™ is computer aided experimentation for science education. For that purpose, a large number of experiment instructions are available in the form of web pages. Users can navigate through these in the same way as they would browse the Internet and all the operations can be controlled with the help of facilities incorporated into the web pages at appropriate points. Experiment Instructions for carrying out experiments can also be written by teachers using standard HTML tools and the programming environment made available for the purpose. All kinds of Internet tools and technologies, such as multimedia sequences, animations, films, etc. can be incorporated into the experiment files. A software measuring lab is available for solo experimentation that utilizes all the functions of the functions of 3B NETlog™ interface device. A wide range of graphical tools is available for processing experimental data. Thanks to its networking capability, 3B NETlab™ is ideally suited for use in schools. It enables teachers to check on the status and results of students' experiments from their own desk. Conversely, an experiment that is being carried out by the teacher can be followed by students on their own monitor screens.

9982-1000544

Licensing:

3B NETlab™ contains a specified location license for the normal use of the computer program throughout a school or educational establishment, including the preparation of school or student work at home.

System requirements:

- Windows 2000/XP Prof. (SP3) with Internet Explorer 7, Vista Business (SP2) with Internet Explorer 7, Win 7 Prof. with Internet Explorer 8
- Intel Pentium III / AMD Athlon 600 MHz or higher
- 128 MB RAM
- 100 MB free hard-disk space
- Monitor with a resolution of 1024x768 pixels or higher
- USB port



3B NETlog™

3B NETlog™ can be used as an interface for data acquisition linked to a computer, or as a hand held instrument with a data-logger for measurements of current and voltage or in combination with various sensors. It incorporates sensor connectors with automatic identification of sensors. It can be connected to a computer via USB. Can optionally be connected via Ethernet to the same sub-net of an Intranet. Includes USB cable and installation CD with data transfer program and plug in power supply.

Channels: 2 Differential amplifiers (A and B)
 Measuring ranges: 0 – ±200 mV, 0 – ±2 V, 0 – ±20 V
 Connectors: Two twin 4 mm safety sockets

Current input:
 Channel: Parallel to A
 Measuring ranges: 0 – ±200 mA, 0 – ±2 A
 Connector: One twin 4 mm safety socket

Analogue sensor inputs:
 Channels: 2 (A and B)
 Connectors: Two 8-pin miniDIN sockets
 Sensor identification and calibration: Automatic
 Triggering: Quasi-continuous
 Sampling rate: 50 kilosamples/s
 Resolution: 12 bit

Voltage outputs:
 Channels: 2 (A' and B'), with common ground connection
 Voltage amplitude: 0 – ±5 V
 Connectors: Two twin 4 mm safety sockets

Analogue sensor outputs:
 Channels: 2 (A' and B')
 Connectors: Two 8 pin miniDIN sockets
 Sampling rate: 10 kilosamples/s
 Resolution: 12 bit

Digital Inputs:
 Channels: 4 (A, B, C, D)
 A: TTL
 B: TTL, high-speed sampling rate, 100 kilosamples/s
 C, D: High-speed optical coupler (galvanically isolated)
 Connector: One 8 pin miniDIN socket

Digital outputs:
 Channels: 6 (A', B', C', D', E', F')
 Signal: TTL
 Connector: One 8 pin miniDIN socket

Additional data:
 Computer connection: USB port
 Internal data storage: 128 k
 Monitor display: Large display (64x122) for data on all channels
 Power supply: 4.5 V DC/300 mA or 3 batteries LR6 AA alternative-ly 3 NiCd or 3 NiMH rechargeable batteries

3B NETlog™ (230 V, 50/60 Hz)

9982-1000540

3B NETlog™ (115 V, 50/60 Hz)

9982-1000539

3B NETlog™ with Ethernet Port (230 V, 50/60 Hz)

9982-1000009

3B NETlog™ with Ethernet Port (115 V, 50/60 Hz)

9982-1000541





9982-1000578

Blood Pressure Sensor

Sensor box for measuring blood pressure of a test subject using the oscillometric method with the aid of a cuff to fit around the extremities. It is possible to determine the highest systolic and lowest diastolic pressures, evaluate of pulse rate by means of an acoustic sensor and illustrate the Korotkov sound.

Pressure range: 0 mm Hg to 300 mm Hg (0 to 400 hPa)

Overload-proof: Up to 1500 hPa

Sensor type: Precision pressure sensor, calibrated and temperature compensated

9982-1000578

Relative Pressure Sensor, ±1000 hPa

(not shown)

Measurement range: 0 – ±1000 hPa

Accuracy: ± 1%

Sensor type: Semiconductor sensor

Hose nipple: 4 mm dia.

Silicone tube: 1 m

9982-1000548

Microphone (not shown)

Frequency range: 50 Hz – 20 kHz

Microphone cable: 2 m

9982-1000565

Human Pulse Sensor Box (not shown)

Measurement range: Pulse rates from 40 – 160 beats/min

Safety category: Safety class II, classification BF

9982-1000575

Barometer (not shown)

Measurement range: 700 hPa – 1200 hPa

Resolution: 0.1 hPa

Accuracy: 1.5% of the maximum value of the measuring range

Sensor type: Semiconductor sensor

9982-1000549

Skin Resistance Box (not shown)

Measurement range: 1 MΩ – 10 MΩ

Input resistance: >100 kΩ

Safety category: Safety class II, classification BF

9982-1000576



9982-1000579

pH Sensor (not shown)

Measurement range: pH 0 – 14

Sensor type: Ag-AgCl combination electrode, gel filled, not refillable

Accuracy: pH 0.05 in range from 20°C – 25°C

Resolution: pH 0.01

Response time: ≤ 1 s to reach 95% of final value

9982-1000556

Additionally recommended:

9982-1002753 Buffer Solution

Buffer Solution (not shown)

Set of buffer solutions in three flasks with pH values of 4.00, 7.00 and 9.00.

Volume: 250 ml each

9982-1002753



9982-1000577

NEW

Response Box

Microprocessor-controlled box with a foot switch and three coloured finger-operated buttons (blue, green and red) and a combined LED, which can light up in the same colours as the hand buttons or in white to indicate use of the foot switch. Once the LED has lit up in some arbitrary colour, the response time before the appropriate switch has been activated is measured. For use in conjunction with 3B NETlog™ unit (9982-1000540/9982-1000539) for manual measurements or measurement acquisition via computer. Includes connector lead with 8-pin miniDIN plugs.

Duration of measurement: max. 9.2 s

Display resolution: 1/100 s

Footswitch connector: 3.5 mm jack plug

9982-1000577

ECG/EMG Box

Sensor box for reading electrocardiograms (ECGs) and electromyograms (EMGs) on skeletal musculature in three standard leads as defined by Einthoven. Leads can be selected at the press of a button and are indicated by LEDs.

Input resistance: > 10 MΩ

Output voltage: max. ± 1 V

Blocked frequency: 50 – 60 Hz

9982-1000579

Relative Pressure Sensor, ±100 hPa

(not shown)

Measurement range: 0 – ±100 hPa

Accuracy: ± 1%

Sensor type: Semiconductor sensor

Hose nipple: 4 mm dia.

Silicone tube: 1 m

9982-1000547

Absolute Pressure Sensor, 2500 hPa

(not shown)

Measurement range: 0 – 2500 hPa

Accuracy: ±1%

Resolution: 1 hPa

Sensor type: Semiconductor sensor

Hose nipple: 4 mm dia.

Plastic syringe: 20 ml

Silicone tube: 1 m

9982-1000546

Light Sensor (not shown)

Measurement ranges: 0 – 600 lux, 0 – 6000 lux, 0 – 150,000 lux

Resolution: 0.8 lux, 8 lux, 200 lux

9982-1000562

Temperature Sensor, Pt100 (not shown)

Measurement range: -50°C – 150°C

Resolution: 0.1 °C

Accuracy: 0.1% of measured value plus 0.25°C

Sensor cable: 1 m, with silicone insulation

Sensor type: Pt100 thermocouple

9982-1000550

Humidity Sensor (not shown)

Measurement range: 0 – 95% (non condensing)

Sensor type: Capacitive sensor

Accuracy: 3% of RH plus 1% in the range from 0% –95%
5% of RH plus 1% in the range from 0% –5%

Resolution: 0.1%

Response time: 15 s

9982-1000554

Conductivity Sensor (not shown)

Measurement ranges: 0 – 200 μS, 0 – 2 mS, 0 – 20 mS

Resolution: 1 μS, 10 μS, 100 μS

Sensor type: Measurement electrode using four wire technology, with graphite cells and integrated Pt100 temperature sensor

Accuracy: 5% without calibration, 0.5% with calibration

Sensor cable: 1.5 m

9982-1000553

Enhance your lessons with a multitude of easily conducted experiments using the GASTEC gas detector.

Experiments:

Analysis of stuffy and of fresh air in a room.
Investigation of how carbon dioxide and oxygen content changes in the atmosphere due to the following processes:

- Burning of a candle.
- Breathing of people and animals.
- Photosynthesis of plants.
- Burning of organic substances.

Gas Analysis Made Child's Play:

- Open glass test tube using the tip to break off both ends and close the ends using protective rubber stoppers.
- Push the test tube into the hand pump and hold it at the required position.
- Suck air into the tube using the pump and wait 30 seconds.
- Take the test tube out of the hand pump and read off the gas content from the degree of coloration.



Water / Earth / Air

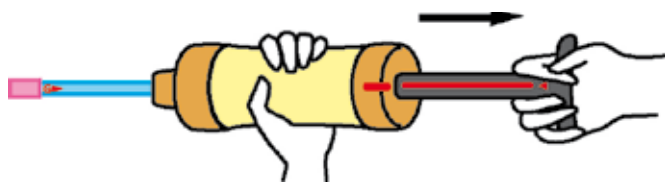

Set of 10 CO₂ Test Tubes, 0.03 – 1.00% by vol. (not shown)
Set of 10 test tubes for the GASTEC gas detector, used for detecting changes in carbon dioxide content in the atmosphere due to combustion processes, for comparison of fresh and stuffy air or observing photosynthesis in plants.

9982-1012524

Set of 10 CO₂ Test Tubes, 0.5 – 8.0% by vol. (not shown)
Set of 10 test tubes for the GASTEC gas detector, used for detecting changes in carbon dioxide content in the atmosphere due to combustion of organic materials or the breathing of people and animals.

9982-1012526

Set of 10 O₂ Test Tubes, 6 – 24% by vol. (not shown)
Set of 10 test tubes for the GASTEC gas detector, used for detecting oxygen content of air in the atmosphere.

9982-1012527

Set of 10 Pairs of Protective Rubber Stoppers (not shown)
Set of spares including 10 pairs of protective rubber stoppers for test tubes used with the GASTEC gas detector.

9982-1012528

GASTEC Gas Detector

Easy to use gas detector for analysing gas content in the atmosphere. For use in countless fundamental experiments. Includes hand pump and accessories for pumping air into specific test tubes, from which the gas content can be read off by means of the degree of coloration of the adsorption material.

Contents:

- 1 Hand pump for pumping in samples
- 1 Break-off tip for test tubes
- 1 Set of 10 pairs of protective rubber stoppers
- 1 Sealing grease
- 1 Carrying case
- 1 Teaching poster with suggested experiments, many illustrations and detailed instructions

9982-1012504

Additionally required:

- 9982-1012524 Set of 10 CO₂ Test Tubes, 0.03 – 1.00% by vol.**
- or
- 9982-1012526 Set of 10 CO₂ Test Tubes, 0.5 – 8.0% by vol.**
- or
- 9982-1012527 Set of 10 O₂ Test Tubes, 6 – 24% by vol.**

NEW



9982-1012504

Experiments

BEST SELLER

9982-1003787



9982-1005086

MicroLife Water Field Kit

The Kit is designed for use in the lab or in the field.

It allows users to study:

- Biological Oxygen
- Dissolved Oxygen
- Orthophosphates
- Turbidity
- E.Coli
- Nitrate
- pH
- Conductivity
- Nitrite
- Temperature

Supplied with:

1 Comboplate, 1 Set of Spatulas and Forceps, 4 Pipettes, 1 Thermometer 0 – 50°C, 1 LED with battery connector, 1 vial of Ammonium Molybdate, 1 vial of Nitrite Indicator Solution, 1 vial of Ascorbic Acid Powder, 1 vial of Zinc Powder, 1 vial of Universal Indicator Solution, Dissolved Oxygen Colour Chart, Universal Indicator Chart, small plastic vial with cork stopper, 10 Dissolved Oxygen Tablets, 2 Water Sample vials, 1 turbidity disc, 1x Standard Conductivity Solution, worksheet.

30x13x8 cm; 0.3 kg

D/E

9982-1005086

Device kit for water, soil and air experiments – ECOLABBOX

The Ecolab box is a veritable mobile laboratory for carrying out water, soil and air experiments out in the field. Thanks to the special case, you can detect and measure the most important substances that have an effect on our environment. The high quality, stable case lining is water-resistant and is very easy to clean. The case and the linings are made of 100% pure recycled polypropylene. An adjustable carrying belt for use when out and about – on a bicycle for example – is also provided. It is particularly suited for environmental groups and schools (for pupils aged 12 and above). The ECOLABBOX can be used to test the following parameters (there are enough reagents for measuring these parameters for 50 experiments):

- pH values in water, from pH 3 to 9
- nitrates in water, 10 to 80 mg
- ammonium in water, 0.05 to 10 mg/l
- phosphates in water, 0.5 to 6 mg
- nitrites in water, 0.02 to 1.0 mg
- total hardness in water, 1 drop = 1°dH (German hardness scale)
- pH values in soil, from pH 3 to 9
- nitrates in soil, 10 to 80 mg/l
- phosphates in soil, 0.05 to 6 mg/l
- ammonium in soil, 0.05 to 10 mg/l

The reagents used to determine the above parameters do not pose any disposal problems! This still applies if the reagents have to be disposed of without being diluted, or are disposed of with the sample solution.

This is because all the reagents are in water hazard class 0!

The ECOLABBOX contains other important experiment tools for working outdoors or in the classroom:

- Colour chart for determining the values of each individual parameter
- Filtration stand for carrying out filtration safely in the case
- Magnifying glass for recognising small living organisms more easily
- Special tweezers to look at small living organisms without harming them
- Water-resistant DIN A 4 underlay for biology experiments
- Filtration paper for making soil extraction solutions
- Funnel, 1 for each work and test flask, 100 ml and 250 ml
- Graduated beaker and plastic pipettes

Device for Demonstrating the Anomaly of Water

Apparatus for demonstrating the thermal anomaly of water, measuring its thermal expansion and determining its maximum density. Comprises a Duran glass vessel with an inlet tube and two GL screw connections for mounting the riser tube with a mm scale and a temperature sensor or thermometer. Includes stirring rod.

Volume: 250 ml
 Riser tube: 400 mm
 Capillary: 1.5 mm dia.
 Hose nipple: 8 mm
 Overall height: approx. 500 mm

9982-1002889

NEW

9982-1002889

9982-1002793

9982-1002808

9982-4000036



ECOLABBOX – German

9982-1003787

ECOLABBOX – English

9982-1003792



9982-1003784

Oxygen Test Kit Complete

The test kit contains sufficient solutions for carrying out 110 oxygen-tests. All the necessary material for carrying out the tests are stored in an easy to survey, practical portable box. Content: 6 bottles of reagent and titration solution, glass bottle, special vessel and syringe with slip on spout. Description in English and German. 25x12x6 cm; 0.9 kg

9982-1003784

Oil-Test Paper and pH Test Paper

To test for oil in water or in soil and to find hydrocarbons, especially in fuel (Diesel) and motor oil. Even if the water is self-coloured, a deep blue colouring of the test tape indicates even a small oil content. Package with 100 tapes 20x70 mm. Description in English and German.

8x5x2.5 cm; 0.07 kg

9982-1003783



9982-1003783



9982-1003799

Watertest Laboratory

A really compact box – laboratory for a fast analysis of waters (e.g. drinking, water, surface water, water of aquaria). All the applied chemicals are neutral in reaction to the environment, which means, none of the test solutions endanger water. The used test solutions can be disposed of via the home waste water system. Sufficient for 50 to 60 tests:

- Ammonium 0.05 – 10 mg/l
- Nitrate 10 – 80 mg/l
- Nitrite 0.02 – 1.0 mg/l
- Phosphate 0.5 – 6.0 mg/l
- ph-Value 5.0 – 9.0
- 1 Drop = 1° German hardness (dh).

Description in English and German.

33x22x4 cm; 1.2 kg

9982-1003785

Complete Refill Kit Content (not shown)

9982-1003786

9982-1003785



pH-Indicator Test-Sticks

For fast pH-value determination. The indicator area on the plastic stick will not fade out (will not bleed). Clearly distinguishable scaling. Package with 100 tapes. Description in English and German. 9x6.5x1 cm; 0.05 kg



9982-1003794

Measuring Range pH 0 – 14

9982-1003794

Measuring Range pH 4,5 – 10

9982-1003796

Measuring Range pH 0 – 6

9982-1003795

Measuring Range pH 7 – 14

9982-1003797

Universal Indicator Paper

Universal indicator paper for pH 1 – 11 measurements. The roll (5 m long and 10 mm wide) is contained in a plastic dispenser (pH gradation 1.0) with a reference colour scale.

6x6x1 cm; 20 g

9982-1003799



Robust Wire Sieve Net

Especially robust reinforced net version. This landing net also has a reinforced net at the edges and therefore allows you to catch small animals directly off the ground. Any possible bending is avoided by the strong and simple construction.

Length: 100 cm. Diameter: 200 mm.

21x12 cm; 0.5 kg

Delivery without telescope pole (9982-1003780)

9982-1003779



9982-1003781
9982-1003782

Options for 9982-1003778, 9982-1003779, 9982-1003781, 9982-1003782, 9982-1013196

Telescope Pole Universal

Extendable from 145 to 275 cm

9982-1003780

Water Landing Net

A very robust water landing net with a nylon net, for catching fleas, bugs, floating particles and water insects. Holes 0.8 mm. Diameter of the net ca. 200 mm, depth 310 mm adaptable to the telescope pole (9982-1003780).

150x270 cm; 0.05 kg

Delivery without telescope pole (9982-1003780)

9982-1003778

Plankton Net

Sturdy plankton net version – made of screen gauze – is to be used with the telescope pole, thread inclusive, 200 mm diameter. A collecting, screwable vessel with 100 ml content is located at the end of the net.

21x2 cm (dxh); 0.225 kg.

Delivery without telescope pole (9982-1003780)

Plankton Net, with 65 µl gauze

9982-1003781

Plankton Net, with 105 µl gauze

9982-1003782



9982-1013196
9982-1003780

NEW

Water sampling beaker

This high-quality sampling beaker design includes a graduated polyethylene beaker (1,000 ml) with spout and universal attachment with a hole for the spring mechanism of the fibreglass telescopic rod (9982-1003780).

Using this sample beaker, your pupils will be able to easily take samples from the surface of the water. The switchable beaker is held with an adjustable clamp made of high-grade steel. This can be used to rotate the beaker to change the pouring direction. Another advantage of this system is the lockable adjustable bracket (0 to 180°) that enables the tilt angle of the beaker to be changed.

Delivery without telescope pole (9982-1003780)

9982-1013196

Replacement beaker 1,000 ml (not shown)

9982-1013197



**BEST
SELLER**



9982-1005074

Stethoscope

Ideal for introducing your students to “Blood and Circulation” or for reinforcement of the topic. This good value for money stethoscope comes with a flat chestpiece and black tube.

9982-1005074



9982-1005075

Blood Pressure Meter

Excellent for realistic biology lessons. This robust sphygmomanometer consists of an easy-care arm cuff made of cotton, an uncomplicated rubber ball pump and a display scale for readings up to 300 mmHg. Supplied in a case.

9982-1005075



9982-1009146



9982-1012415

Piko 1 Electronic spirometer

Carries out 2 types of measurement:

- Measurement of peak expiratory flow rate (scale of 15 to 999l/min)
- Measurement of maximum expiratory volume per second (scale of 0.15 – 9.99 litres)

Pocket-sized model (35 g, dimensions: 75x35x20 mm). Very easy to use: Just one button. Memory recall of 96 measurements. LCD screen.

Delivered with 1 reusable mouthpiece and 2 batteries.

9982-1012415

Spirometer Replacement Mouthpieces

Made of plastic, 10 pcs for 9982-1012415 Piko 1 For attachment and replacement

9982-1009146

M3 Electronic arm blood pressure meter (Omron)

- Large screen
 - Simultaneous display of all readings; Diastole, Systole, Pulse and Time
 - Detection of irregular heart beats
 - Saves up to 42 measurements, indicating the date and time of the blood pressure measurement
 - Intellisense system. Average of last 3 measurements
 - Indication of blood pressure outside acceptable norms
 - Delivered with storage case and set of batteries
 - Clinical validation
- 3 year warranty

9982-1006006



9982-1006006



9982-1006007



9982-1006007

Cardio HITRAX Pulse

Indication of day, time, hour, minute, second, with a display showing heart rate, maximum and average heart rate, and stopwatch (1/100e s). Back lighting LED. Alarm. Delivered with thoracic belt.

9982-1006007

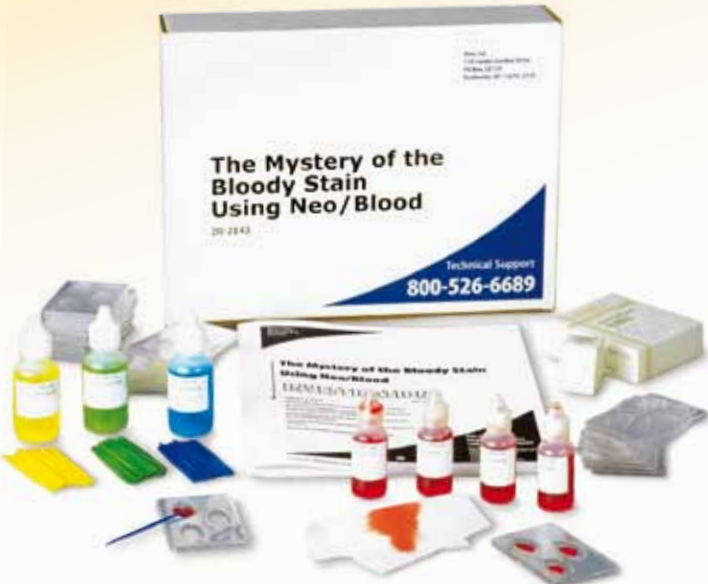

9982-1005979

Mystery of the Blood Stain

Students as forensic pathologists!
Based on a stain of blood found at a fictitious crime scene, a murder has to be resolved. The first thing to do is to check whether the stain is really a blood stain. Next, the blood group and Rhesus factor have to be identified and then compared with samples of the victim and various suspects. As a result, the murderer can be convicted and the crime solved. This simulation experiment guarantees an exciting lesson in which your students will learn a lot about blood groups and how to identify them.

Supplied with:

3 Simulated Sera (Anti-A, Anti-B, Anti-RH) (each 30 ml), 40 Blood typing trays, 1 Cheese cloth, 1 Crime Scene Simulated Neo/BLOOD sample (25 ml), 3 Suspect Simulated Neo/BLOOD samples (each 25 ml), 40 Stirring sticks, blue, 40 Stirring sticks, yellow 40 Stirring sticks, green, description. Suitable for secondary school education.

30x23x6 cm; 1 kg

D/E/S/I

9982-1005979

ELISA HIV/AIDS-Test

AIDS is already an important topic for secondary school students!
But how does an AIDS test work?

The students study the immunobiological phenomenon of the antigen-antibody reaction. They learn that the ELISA immunoassay is an important tool to detect the HI virus. They simulate ELISA screenings with artificial blood serum of 10 fictitious individuals to determine their HIV status. In this way, they gain insight into the field of immunobiology and the particular meanings of terms such as "positive" and "negative" and "false positive" and "false negative". The students get to know basic concepts of immunobiology and understand how the ELISA HIV screening test works. They observe simulated ELISA antibody-antigen reactions and finally analyze the ELISA test result.

Supplied with:

20 8-microwell strips, 8 Micro-spatulas, 10 Plastic pipettes, 10 Medicine cups, 2 Vials with glass beads coated with simulated HIV antigen, Simulated anti-human antibody enzyme linked conjugate (10 ml), 2 Simulated chromogen (10 ml), 9 Simulated patients sera (10 ml), 1 Simulated negative control serum (10 ml), 1 Simulated low positive control serum (10 ml), 1 Simulated high positive control serum (10 ml), description.

30x22x10 cm; 1.5 kg

D/E

9982-1005974



9982-1005072

Blood Typing with Rhesus factor

This long-life experimental kit allows your students to determine blood groups with Rhesus factor without any risk of infection. They can examine the artificial "blood" of 4 fictitious people and determine their blood group and Rhesus factor. Distinct agglutinations can be seen. The size of red and white "blood corpuscles" and the number of corpuscles per mm³ can be determined using a microscope.

Supplied with:

4 dropper bottles of artificial blood (A, B, AB and 0), 1 dropper bottle each of artificial anti-A, anti-B and anti-Rh serum, 48 washable permanent test trays with 3 wells, 50 mixing sticks, detailed teacher's information with agglutination diagram. The supplied materials suffice for approx. 45 to 50 samples.

24x17x6 cm

D/E

9982-1005072



9982-1005974

NEW



9982-1010175

Newton's Colour Disc, with DC Motor

Newton's Colour Disc for demonstrating additive combination of colours. Mounted on a stable box, moved by a DC motor.
 Diameter of disc: 90 mm
 Motor: 4 ... 6 V DC
 Connection: 4 mm safety sockets
 Dimensions: 135x85x130 mm³

9982-1010175

Additionally required:
 9982-1002849 Pair of Safety Experiment Leads, 75 cm
 9982-1003560 DC Power Supply 1.5 – 15 V, 1.5 A (230 V, 50/60 Hz)
 or
 9982-1003559 DC Power Supply 1.5 – 15 V, 1.5 A (115 V, 50/60 Hz)

Motor with Drive Control

Controllable motor for spinning the colour disc fast (9982-1002983). With disc holder and clamp for attachment to a stand rod. Including plug-in power supply.
 Control range: 0 – 25 rev/s
 Rotation direction: reversible
 Dimensions: approx. 110x70x45 mm³
 Weight: approx. 0.2 kg

9982-1002705

Additionally recommended:
 9982-1002835 Tripod Stand, 150 mm
 9982-1002934 Stainless Steel Rod, 470 mm



9982-1002983



9982-1002705

9982-1010194

NEW



Newton's Colour Disc, with Crank

Newton's Colour Disc for demonstrating additive combination of colours. Mounted on a stable base, moved with crank.
 Diameter of disc: 178 mm
 Dimensions of the base: 143x90x282 mm³

9982-1010194

“Addition of Colours” School Apparatus

Handy desk-top device for investigating additive mixing of the primary colours, red, green and blue (RGB) to make any other colour. Three adjustment mechanisms allow any intensity of each primary colour to be selected so that various components of LED light can be mixed and observed with the help of a frosted glass screen. Includes 12 V/500 mA plug-in power supply and instruction manual for a colour triangle.
 Dimensions: 192x65x120 mm³

9982-1012821

NEW



9982-1012821

Laser Ray Box

Laser diode capable of producing up to five parallel rays, for use with related board (9982-1003056). In metal housing with magnetic foil. The number of emerging light beams can be selected electronically via switches. Power is supplied via a plug-in unit or batteries that are automatically disconnected after 60 minutes.

Diode laser: 5 beams, each max. 1 mW,
Laser safety class II
Wavelength: 635 nm
Separation of laser beams: 18 mm
Plug-in power supply: Primary 100 – 240 VAC,
Secondary 3 V DC, 300 mA
Battery compartment: for 2x 1.5 V AA-batteries
(batteries not included)
Dimensions: approx. 110x60x20 mm³

Laser Ray Box (230 V, 50/60Hz)**9982-1003052****Laser Ray Box (115, 50/60 Hz)****9982-1003051****Board for Laser Ray Box**

Magnetic board for conducting experiments with laser ray box (9982-1003052 resp. 9982-1003051). With a removable prop for inclining board.
Dimensions: approx. 600x450 mm²

9982-1003056

9982-1003052
9982-1003051

NEW

9982-1003049

9982-1003056

Equipment Set “Optics with Laser Ray Box”

Set of optical components for use in combination with a laser ray box (9982-1003052 resp. 9982-1003051) and related board (9982-1003056). This equipment set is ideal for conducting a wide variety of experiments on ray optics. Equipped with magnetic foil, the components can be easily attached to the board and aligned. Six work templates with pre-defined positions facilitate experiment setup. The beam paths can be observed from a relatively long way away without any need for darkening the room.

Basic length: 100 mm each (in most cases)
Thickness: 15 mm each.

Contents:

1 Biconcave lens	1 Convex mirror
4 Biconvex lenses	1 Flat parallel block (60x100 mm ²)
1 Plano-concave lens	1 Prism
1 Hemispherical body (45 mm)	1 Wave guide (20x200 mm ²)
1 Hemispherical body (75 mm)	6 Foils (410x290 mm ²)
1 Plane mirror	1 Experiment guide
1 Concave mirror	

9982-1003049

Additionally required:

9982-1003052 Laser Ray Box (230 V, 50/60 Hz)

or

9982-1003051 Laser Ray Box (115 V 50/60Hz)**9982-1003056 Board for Laser Ray Box****Supplemental Set “Optics with Laser Ray Box”**

Supplementary kit to the demonstration laser optic set with laser ray box, consisting of 13 optical components for more advanced experiments on geometric optics, e.g. experiments using air lens that show why optical elements cause either negative or positive refraction. All components are coated with magnetic foil.

Base length: 100 mm each (in most cases)
Thickness: 15 mm each

Contents:

1 Biconcave glass lens	2 Flat parallel blocks (rectangular)
1 Biconvex glass lens	2 Plane mirror
1 Equilateral glass prism	1 Biconcave air lens
2 Rectangular glass prism	1 Biconvex air lens
1 Flat parallel block (square)	1 Air prism

9982-1003050

9982-1003050

Nerves of Steel – Great experiments for simulating the conduction of impulses along nerve fibres according to Prof. Dr. Matthias Ducci / Prof. Dr. Marco Oetken

Exciting experiments for interdisciplinary teaching of year 11 to 13 classes. A model system for simulating the conduction of impulses is now finally available! Many biology teachers have complained about the lack of suitable model systems for simulating the conduction of impulses along nerve fibres, considering that neurophysiology is an established component of the advanced level syllabus. We have developed a unique electrochemical model experiment for effective illustration of this complex topic, in cooperation with Prof. Dr. Matthias Ducci (teacher training college PH Karlsruhe) and Prof. Dr. Marco Oetken (teacher training college PH Freiburg). Try it – you'll love it!



Prof. Dr. Matthias Ducci

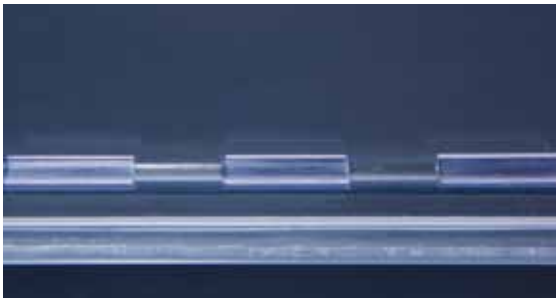

Starting position of the simulation of saltatory conduction

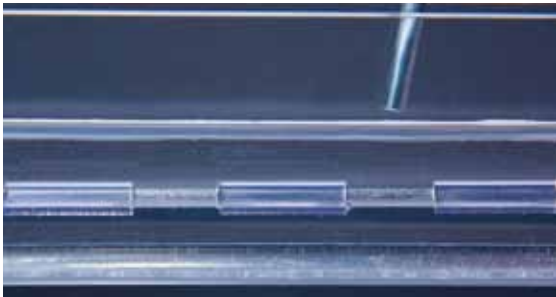

The zinc electrode is put into the electrolytic solution

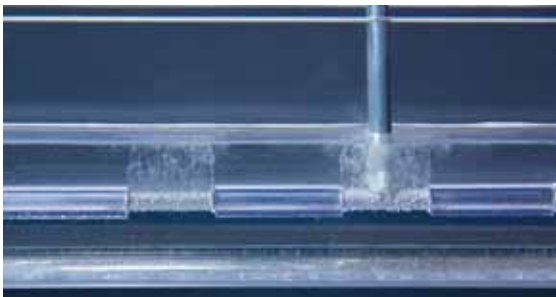

After the zinc electrode contacts the iron rod a reaction can be seen through the bubbles which represents the conduction of impulses of nerve fibres

Nerves of Steel

The model experiments are based on the property of iron to develop a protective oxide coating in acid solutions under specific conditions. This impressive analogical model is based on the reversibility of the process of passivation and the appearance of a reactivation along a long iron rod. The materials provided allow the students to use the model to demonstrate continuous and saltatory conduction as well as the principle of transmission of neurotransmitters.

The following experiments can be carried out:

- Simulation of continuous conduction along non-myelinated axons
- Simulation of saltatory conduction by means of a model experiment
- Transmission of information by neurotransmitters

Scope of delivery:

- 1 Plexiglas trough,
- sand paper,
- 3 iron rods,
- 1 zinc electrode,
- 15 jackets for isolation of sections of the iron rod, detailed experimental instructions.

The required chemicals (hydrogen peroxide, sulphuric acid, sodium chloride solution) are not included.

12x12x35 cm; 0.5 kg

D/E

9982-1000538

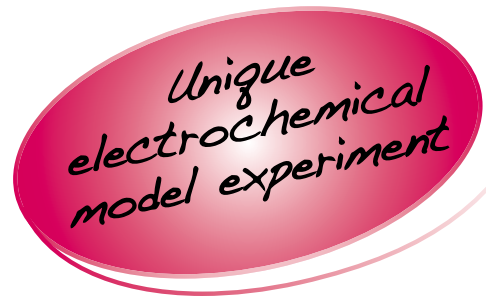

9982-1000538

Photosynthesis Equipment Set

The equipment set can be used to observe the photosynthesis process and establish the dependencies between light intensity, the wave length of the light, the CO₂ content and other parameters. The equipment set is conceived for use in school experiments, but can also be used for teacher-led demonstrations. The CD-ROM included with the set contains extensive teacher information with the theoretical background to each experiment and an evaluation sheet (log) to be completed by the pupils.

Topics of the experiments:

- Proof of the oxygen produced by the plant
- The dependence of photosynthesis on light intensity
- The dependence of photosynthesis on light wavelength
- The dependence of photosynthesis on the CO₂ content of the water
- The dependence of photosynthesis on water temperature
- The dependence of photosynthesis on the number of the shoot sections

Scope of delivery:

- Beaker, 1 l
- Funnel
- Universal bracket
- 4 Collection vessels
- 2 Rubber bungs
- 4 Colour filters (blue, yellow, red, green)
- 4 Neutral density filters
- Instructions on CD-ROM in German and English

9982-1012864

Additionally required:

A source of light e.g. illumination equipment (9982-1012866) as shown in the diagram



9982-1012866



Plant Physiology

NEW



9982-1012864

Plant Enzyme Kit – Microzyme Phosphatase

This new kit was developed by SAPS (Science and Plants for Schools), Homerton College, Cambridge, UK. The kit uses Microscience techniques to help students understand the various factors that influence enzyme activity. Starting with Mung Beans, an extraction of Phosphatase is accomplished followed by a series of semi-quantitative measurements. These include:

- Phosphatase activity
- Effect of pH on activity
- Effect of concentration on rate
- Effect of temperature (Heat Stability)
- Effect of time on product formation
- Effect of inhibitors on activity

Scope of delivery:

1 Comboplate®, 1 pack of pipettes, 1 spatula and forceps, 1 pH guide, 1 syringe (1 ml), 1x 1 ml syringe with adaptor (short length of silicone tubing), 10 micropipettor tips, 2 polypropylene microfuge tubes 1.5 ml) for centrifuging, 20 microfuge tubes for temperature studies.
30x27x10 cm; 0.2 kg

D/E

9982-1005084



9982-1005085

Illumination Equipment for the Equipment Set “Photosynthesis”

The illumination equipment serves as a source of light and a stand for performing experiments regarding photosynthesis with the equipment set 9982-1012864.

Scope of delivery:

Laboratory lamp with power supply 12 V, 2.25 A, primary: 100 – 240 V, 50/60 Hz, tripod, plexi plate 150x150x3 mm, double socket

Illumination equipment for EU countries with a two-pin earthed plug

9982-1012866

Illumination equipment with 3 switchable, primary side, locking adapters

9982-1013528



9982-1005084

Plant Enzyme Kit – MicroChemicals

A class set of buffers and reagent required for use with the Plant Enzyme Kit (9982-1005084).

Scope of delivery:

2 distilled water 50ml, 2 buffer pH3 50ml, 2 buffer pH4 50ml, 2 buffer pH5 50ml, 2 buffer pH6 50ml, 2 buffer pH7 50ml, 2 buffer pH8 50ml, 2 buffer pH9 50ml, 2 sodium carbonate 10% solution 50ml, 2 phenolphthalein phosphate 0.15g (bottle).

30x27x10 cm; 2 kg

D/E/S/I

9982-1005085



9982-1005939

Simulating DNA Paternity Testing

Use agarose gel electrophoresis to test family ties. Simulate how DNA fingerprinting can be used to identify the genetic relationship between child and an alleged father. Your class will use the results of an electrophoresis of non-human DNA, their knowledge of human inheritance and their scientific problem solving skills to solve a scenario-based paternity case and determine the identify of a child's father.

Scope of delivery:

3 DNA samples (mother's DNA, alleged father's DNA, child's DNA) each 150 ml, 2 TBE buffer concentrate (125 ml) 10X, 1 melt and cast agarose gel (400 ml) 0.8%, 1 Neo/BLUE DNA stain concentrate (100 ml) 10X, 1 staining tray, description.

30x22x10 cm; 1.5 kg

D/E/S

9982-1005939

Diagnosing Gene Defects

Examine the genetic mutation responsible for sickle cell anaemia. Your students will use agarose gel electrophoresis to study sickle cell anaemia – a painful and ultimately fatal condition resulting from a genetic mutation which alters the body's haemoglobin. They'll search for changes in a non-human DNA sample to diagnose sickle cell anaemia. In the process, they'll learn about genes and how genetic mutations can cause disease.

Scope of delivery:

4 DNA samples (mother's DNA, father's DNA, daughter's DNA, unborn child's DNA), each 150 ml, 2 TBE Buffer concentrate (125 ml) 10X, 1 melt and cast agarose gel (400 ml) 0.8%, 1 Neo/BLUE DNA stain concentrate (100 ml) 10X, 1 staining tray, description.

30x22x10 cm, 1.5 kg

D/E

9982-1005937



9982-1005937

Genetic Diagnosis of Cancer

Your students will learn how revolutionary breakthroughs in gene technology can be used to not only detect cancer but predict its occurrence based upon hereditary traits. They'll use the electrophoresis results of non-human DNA samples to simulate this procedure. In the process, they'll detect a specific cancer and study the hereditary tendencies of the condition.

Scope of delivery:

DNA samples (Mary's DNA, Samantha's DNA, Fran's DNA, normal control DNA) each 150 ml, 2 TBE Buffer concentrates (125 ml) 10X, 1 melt and cast agarose gel 0.8% (400 ml), 1 Neo/BLUE DNA stain concentrate (100 ml) 10X, 1 staining tray, description.

30x22x10 cm; 1.5 kg

D/E

9982-1005935



9982-1005935



Page 114

ATTENTION:
This experiment requires an electrophoresis chamber and a suitable power supply.
(Page 114)

NEW

DNA Fingerprint

DNA fingerprinting is an important method used in molecular genetics. It is now inconceivable, for instance, for criminal forensics to do without it. Other examples of areas where it can be applied are paternity tests, the analysis of genetic diseases, and identifying victims after natural catastrophes or accidents. During this procedure, DNA fragments are generated by way of a polymerase chain reaction (PCR), and then separated using gel electrophoresis. In our kit, however, the DNA fragments have already been separated so that the pupils only have to carry out electrophoresis. Using the DNA profiles thus obtained, your pupils can draw their conclusions about where they come from (scene of the crime, victim, or suspect). While doing this, the pupils learn about the practicalities of using molecular genetics techniques, and will be able to discuss the DNA profiles in detail once they have completed the experiment. This topic is also a wonderful way of introducing a discussion about other potential applications for DNA fingerprinting, as well as about associated legal and ethical issues.



9982-1013458

Scope of delivery:

DNA from a victim, 120 µl, DNA from the scene of the crime, 120 µl, DNA from suspect n° 1, 120 µl, DNA from suspect n° 2, 120 µl, electrophoresis buffer, 50x conc., 50 ml, agarose, 6 g, DNA staining solution, 200x conc., 1.5 ml

Packaging size: Enough for 10 experiments

D/E/F/S/I/P

9982-1013458

Additionally required:

Electrophoresis chamber (9982-1012852, page 114), power supply (9982-1010263, page 116) and micropipette (9982-1013416, page 111)

ATTENTION:
This experiment requires an electrophoresis chamber and a suitable power supply. (Page 114)

Supplies for Electrophoresis Experiments:

Agarose

for DNA gel electrophoresis, compatible with usual electrophoresis buffers and DNA staining methods, 50 g.

9982-1013341

Methyl Blue Staining Concentrate (not shown)

Concentrated 200 times (2x 1.5 ml), staining in approx. 15 – 20 min. with a high level of sensitivity. Sufficient for approx. 20 stainings of medium-sized gels.

9982-1013342

TAE Electrophoresis Buffer (not shown)

50ml, electrophoresis buffer concentrated 50 times, contains 2M Tris, 1M acetic acid, 50mM EDTA, pH 8.5.

9982-1013343

Gel Loading Buffer (not shown)

Concentrated 6 times – 2x 1.5 ml (with glycerine and bromophenol blue as colour marker).

9982-1013347

100 bp DNA Ladder (not shown)

250µl, ready for use, dissolved in 1x gel loading buffer, with bromophenol blue as a colour marker. Size range of the fragments 100 – 1,000 bp. Sufficient for approx. 25 agarose gels.

9982-1013348

NEW



9982-1013341





9982-1005879

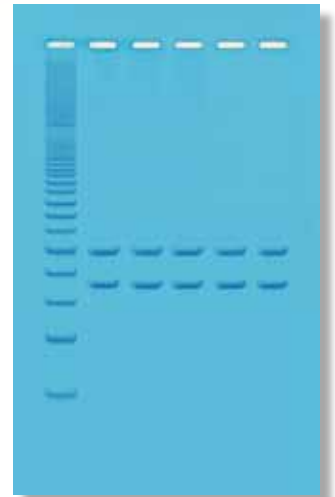

9982-1005883

Polymerase Chain Reaction

This experiment for 6 lab groups introduces students to the principles, practice and applications of the Polymerase Chain Reaction (PCR) without the need for a PCR machine! Polymerase Chain Reaction (PCR) has had an extraordinary impact on various aspects of biotechnology. With PCR, DNA can be amplified and studied. Since the first application of PCR (using the Klenow fragment) to detect sickle cell anaemia, a large number of diagnostic tests have been developed. PCR has made amplification of DNA an alternate approach to cloning experiments. It is used in genome projects in DNA mapping and DNA sequencing. PCR amplification is also being applied to forensic and paternity determination, as well as determination of evolutionary relationships. This simulation experiment does not contain human DNA and does not require a thermal cycler. It is completed in 45 minutes.

Scope of delivery:

Ready-to-Load™ DNA samples, Ultraspec™ agarose powder, practice gel loading solution, electrophoresis buffer, Instastain® Methylene Blue and Methylene Blue Plus™ stain, calibrated pipette, 100 ml graduated cylinder and microtipped transfer pipettes.

Additionally required:

Electrophoresis tank, power supply, automatic micropipette and tips, balance, microwave or hot plate.
30x10x10 cm; 0.5 kg

D/E

9982-1005879

Mitochondrial DNA Analysis Using PCR

In this experiment, your students will use the Nobel Prize winning technique polymerase chain reaction (PCR) to amplify two regions of DNA from their mitochondria. The mitochondria are thought to have evolved from a symbiotic relationship between prokaryotic and eukaryotic cells. Thus as mitochondria have their own DNA that is only inherited via the maternal line they are often used in studies of evolution. This kit shows how PCR is able to amplify DNA from just a few cells. This ability has made PCR very useful to study evolution and in forensics and genetic testing. Your students carry out a simple DNA extraction, followed by PCR, then analyse the results using DNA electrophoresis.

Scope of delivery:

Instructions, proteinase K, PCR beads, control DNA and primers, microtubes, chelating agent, agarose, DNA ladder, practice gel loading solution, gel loading dye, electrophoresis buffer, gel stain.

Additionally required:

Micropipettes to measure between 5 and 50 µl, tips, waterbath, thermal cycler (PCR machine), electrophoresis tank and power supply.
For 25 Students

Time required:

Set up 30 min.
PCR 2 hours or overnight
Electrophoresis 45 min.

D/E/F/S/I

9982-1005883

Some components of this kit must be stored at -20 °C !

EdvoCycler™ PCR Machine
(9982-1005882)
Page 113



ATTENTION:
This experiment requires an electrophoresis chamber and a suitable power supply.
(Page 114)

Population Genetics and Evolution

Collect and analyze data of readily observable genetic traits! Your students will determine the phenotype, genotype and frequency of easily observed human traits. Then they'll identify the dominant and recessive genes for each trait. With the class as a sample population, your students will use a variety of taste test papers to determine the percentage of individuals who can detect a unique taste. They'll then apply the Hardy-Weinberg Principle to calculate the allele frequencies for this trait and compare their class data with an ideal population. In the second part of this lab investigation, your students will use allele cards to model allele frequency change in an ideal population, a population on which selection is acting, an example of heterozygote advantage and as a result of genetic drift. The investigation includes detailed coverage of natural selection, the Hardy-Weinberg equation and other related topics to better prepare your students for their exams. Lab Activities Include: Estimating frequencies for a specific trait within a sample population; case studies; eight lab stations.

Scope of delivery:

32 PTC paper, 160 cards printed with A, 160 Cards printed with a 8 plastic coins, description in German and English.
30x23x6 cm; 1.5 kg

D/E

9982-1005931

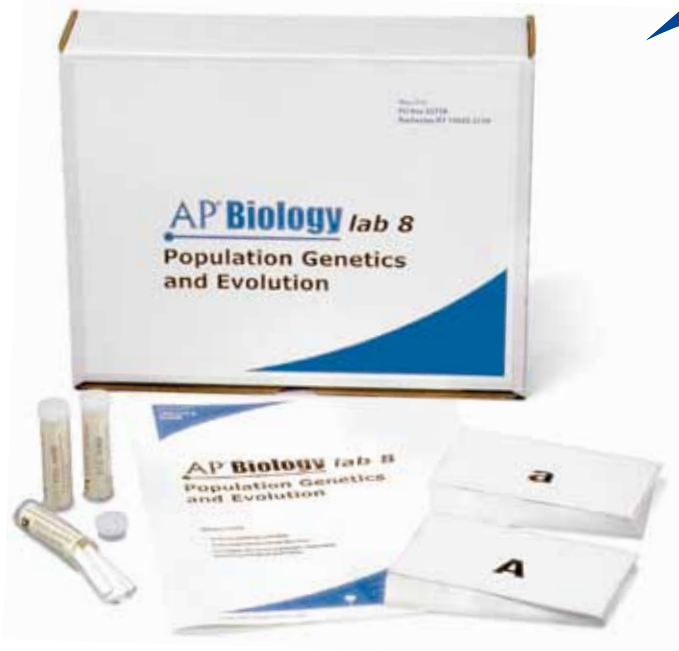

9982-1005931

Genetics



9982-1005087

Fruitfly Genetics

This unique kit contains simple activities designed to teach basic fruit fly genetics without using live flies. *Drosophila Melanogaster* is used without the inconvenience of maintaining live fruit fly cultures. Students can perform crosses using plastic pieces printed with features allowing them to observe and simulate sex determination, single factor inheritance, double factor inheritance, sex linkage, dominance and recessiveness.

Scope of delivery:

15 sheets each, with snap apart features showing male and female and 4 types of fruit flies. Teacher's Guide and Student instruction sheet included.

35x22x2 cm; 0.1 kg

D/E

9982-1005087

Genes and Probability

Study the patterns of inheritance and the genetic probability of easily observed and tested traits.

Your students will:

- Apply the laws of chance to genetics
- Demonstrate the effect of dominance in a monohybrid cross
- Demonstrate the effect of incomplete dominance
- Model a dihybrid cross to demonstrate the law of independent assortment

Scope of delivery:

40 coins, plastic, 20 cups, 40 dice, four-sided, 20 opaque discs, blue, 20 opaque discs, red, 20 transparent discs, blue, 20 transparent discs, green, 20 transparent discs, yellow, 5 wax pencils, description in German and English.

30x22x10 cm; 1 kg

D/E

9982-1005930



9982-1005930

Experiments

NEW



9982-1010264

DNA Extraction from Onion

With this easy test on the theme of cellular biology and genetics, you can isolate chromosomal DNA from an onion without a long preparation time, during a class. Your students will learn thanks to this experiment about the basic process of DNA extraction. Everything is included in the kit so that 5 groups can work at the same time. This effective classroom experiment with a high DNA yield will provide enjoyment for your students.

Contents for 15 experiments:

80 ml extraction buffer, 500 mg protease mix, 15 flat-bottomed tubes, 15 round paper filters, 5 funnels, 15 wooden picks, experiment instructions (multilingual).

Dimensions: 20.5x20.5x10.5 cm

Weight: 534 g

D/E/F/S/J/R

9982-1010264

Refill Pack for DNA Extraction from Onion (not shown)

80 ml extraction buffer, 500 mg protease mix, 15 round paper filters.

9982-1010266

Genetics / Osmosis

Fast and highly-effective experiment



9982-1005960

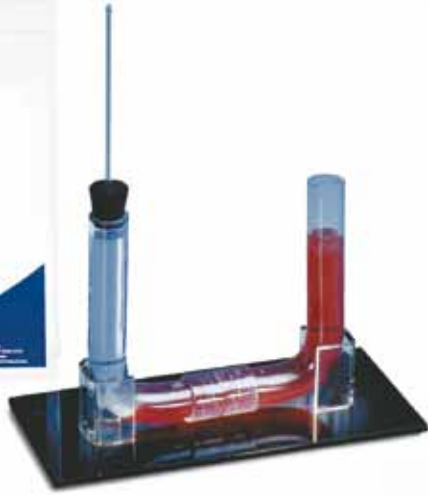

Osmosis Simulation Activity Model

A striking, visual demonstration of osmosis! Quick and easy demonstration provides a solid understanding of osmosis and how it occurs. Your students will gain insight into this critical process as water diffuses across a semi-permeable membrane from an area of higher concentration to an area of lower concentration. The process can be repeated using a variety of solutes in varying concentrations to observe the change in results. The outcome can even be quantified by measuring the amount of liquid that travelled across the membrane.

Scope of delivery:

2 L-Shaped clear tubing, 1 Capillary tube, 1 One-hole rubber stopper, 1 Stand, 1 Food colouring solution (30 ml), 1 Rubber band, 1 Ruler, 10 Semi-permeable membrane sheets, 1 Sucrose (171 g). 30x22x10 cm; 1.5 kg

D/E/I

9982-1005960

Visualizing Osmosis and Diffusion

Vividly demonstrate selective permeability using coloured solutions. Starting with a model cell and a mixture of special dye solutions, your students will observe how the cell's membrane allows one dye to pass, while the other remains within the cell. The resulting colour change provides a vivid demonstration of selective permeability and how the cell absorbs nutrients and discharges waste. The class will also learn how osmosis and diffusion permit the maintenance of equilibrium through the passive transport of water through the cell's semi permeable membrane.

Scope of delivery:

1 Red dye solution (30 ml), 1 Blue dye solution (30 ml), 20 clear cups, 1 Dialysis tubing (4 m), 1 Glucose solution (250 ml), 50 Glucose test strips, 60 Medicine cups, 20 Plastic pipettes, 1 Starch indicator solution (30 ml) (IKI), 1 Starch solution (250 ml), 1 String (4m).

32x24x17 cm; 3 kg

D/E

9982-1005961



9982-1005961

Experiments

NEW

Bacteriology Starter Kit

Microbiology is very important in everyday life, so it is exciting for pupils to learn about it through experimentation. Our bacteriology starter kit contains the basic equipment you will need to carry out microbiology experiments with your pupils in upper secondary school. These user instructions describe general microbiology work methods, and explain how to carry out a range of microbiology experiments:

- Testing for bacteria and carrying out a bacterial count in soil
 - Testing for bacteria and carrying out a bacterial count in water
 - Testing for air-borne bacteria
 - Microscopy of bacteria
 - Determination of generation times at different temperatures
 - Effectiveness of antibiotics
 - Occurrence of natural mutations and their characterisation
- The experiments are designed for 4 groups of pupils and can be easily incorporated into everyday school life.



9982-1013459

Available starting August 2012

Scope of delivery:

4 inoculation loops, 4 Drigalski spatulas, 20 Petri dishes, 20 reagent glasses with tops, 3x nutrient agar (175 ml each), 4 drop pipettes, 4 antibiotic test rings (each with 8 different antibiotics), 50 microscope slides, 50 cover glasses, 2 packs of filter paper, 1 methylene blue solution (10 ml)

D/E/F/S/J/R

9982-1013459

Materials for microbiology:

- 9982-1013502 Antibiotic test rings
- 9982-1013456 Nutrient agar
- 9982-1013457 Inoculation loop
- 9982-1010259 Drigalski spatula, straight head
- 9982-1010258 Drigalski spatula, bent head
- 9982-1010260 Replicator stamp with 12 cloths
- 9982-1010261 Replacement cloths (12 pieces) for the replicator stamp

Large variety of subjects - tried-and-true instructions - all you need for 4 school groups

Drigalski Spatula

This stainless-steel Drigalski spatula is widely used in micro-biological work. It is used to achieve an even spread of single cell and cell-cluster microorganisms on an agar plate. Our Drigalski spatula is available in two designs, both of which are 19 cm in length and made of stainless steel:

Drigalski spatula, straight head

9982-1010258

Drigalski spatula, bent head

9982-1010259

Replicator Stamp with 12 Cloths

The technique with the replica stamp is used to identify and isolate auxotrophic mutants from a bacterial strain. To do so, bacteria or yeast colonies are moved from one agar plate to another. Using the following method, fix a sterile cloth to the stamp with the holding ring and then press the top side of the colony plate to the stamp lightly. A duplicate is then produced using a fresh agar plate. Our replicator stamp is suitable for standard Petri dishes up to 10 cm. You can sterilize the stamp and holding ring with Ethanol. The cloths, made of a cotton polyester mix can be autoclaved. 72x81 mm (HxØ)

Scope of delivery:

Body made of plastic (OVC), plastic-coated aluminium holding ring, 12 cloths 15x15 cm

9982-1010260

Replacement Cloths (12 Pieces) for the Replicator Stamp

9982-1010261



On the Trail of Flavour Enhancers

An interesting experiment set that deals with a highly topical food issue, and at the same time is based on an important chemical/biochemical method of separation (thin layer chromatography – TLC).

Foods containing glutamates can be found in any supermarket, often hidden behind the labelling (yeast extract, spices etc.). These include flavour enhancers in food-stuffs, and their effect on people is a issue that is much spoken about in the media. In biology class, this topic can be easily incorporated into lessons on **metabolic physiology, human health and diseases, nutrition and proteins.**



9982-1013460

NEW

In many syllabuses, carrying out thin layer chromatography is explicitly required. The pupils not only use this test method in our experiment; they also think about it and comment on it. Depending on how the lesson is structured, the pupils can also consider possible errors using this experiment, by discussing potential sources of error in planning and carrying out the experiment (e.g. the lack of a control experiment). By making a comparison with the three glutamic acid standards, the tested samples can be looked at from both a qualitative and a semi-quantitative perspective. In the instructions, you will find both a thorough description of the test, and interesting background information, as the experimentation kit has been developed in collaboration with a food analysis laboratory.

Scope of delivery:

Extraction solution, L-Glutamic acid 50 mg, ninhydrin 300 mg, 20 pleated filters, 50 disposable capillaries, 20 chromatography paper, 5 chromatography chambers, test instructions with interesting background information. Packaging size: Sufficient for 20 tests, with 5 groups working at the same time.

 D/E/S/F/I/P

9982-1013460

*Brand new and
topical - versatile
in classroom
situations*



Interactive Atomic Model According to Bohr for Physics, Chemistry and Biology Classes

This didactically excellent training model greatly simplifies the teaching and understanding of Bohr's model of the atom. The practical hands-on model illustrating the underlying theory allows students to comprehend the topic more directly. Science classes automatically become more "real", easier to grasp and fun to do!

Learning content:

- Atoms, isotopes, ions, noble gas configurations, structure of the elements, covalent bonds, ionic bonds
- Elements, atomic mass, atomic number and the periodic table

Each class kit (9982-1005318/9982-1005319) contains eight student training models (9982-1005320) as well as two demonstration atoms for the teacher. With this completely magnetic demonstration atom you will be able to clearly and quite easily explain Bohr's atomic model to your students on the blackboard. Using the training atom your students will be able to construct their own atoms, isotopes, and even ions. In this manner natural science teaching becomes, simple and lots of fun! Each student training model includes a flat round plastic container holding 30 protons, neutrons and electrons. The lid and the turned over lower part of the container each represent an atom with orbits.

All the benefits at a glance:

- Inter-disciplinary learning game
- Suitable for individual, partner and group work
- Playful learning of natural science subjects
- Easy understanding of processes and structures at the atomic level
- Simple and lots of fun to use
- Appealing 3D design
- Convenient storage



9982-1005318

2 completely magnetic demonstration models for the teacher

Class Kit for Whiteboard

Each class kit for 1 teacher and 8 student groups comes with 2 completely magnetic demonstration models for the teacher (1 white background sheet to be hung up, 2 black atomic nuclei, each with 8 black orbits, 20 protons, electrons and neutrons), 8 student training models each with 2 atoms, 30 protons, 30 neutrons and 30 electrons, instructions.

D/E/S/F/I/P

9982-1005318

Class Kit for Blackboard

Each class kit for 1 teacher and 8 student groups comes with 2 completely magnetic demonstration models for the teacher (1 black background sheet to be hung up, 2 white atomic nuclei, each with 8 white orbits, 20 protons, electrons and neutrons), 8 student training models each with 2 atoms, 30 protons, 30 neutrons and 30 electrons, instructions

D/E/S/F/I/P

9982-1005319

Student Training Model

Supplied with 2 atoms, 30 protons, 30 neutrons and 30 electrons

9982-1005320



Atomic nucleus

Student training model

9982-1005320



9982-1005300

DNA Double Helix Structure Model

- When assembled, students can understand the basic structure of DNA.
- By assembling the model, students will understand the biological terms.
- Easy to assemble and disassemble and can even be used as a decorative model
- The model is grouped by 6 colours
- One can observe the complete product by spinning the model.
- Deoxyribose and 4 bases (A:Adenine, G:Guanine, C:Cytosine and T:Thymine) model types are properly used.
- The description of colours and symbols of sugar, phosphoric acid and 4 bases are well defined and distinguished.
- Size of the purine base (Adenine, Guanine) and the pyrimidine base (Cytosine, Thymine) are different.
- Assembled bases pairs (Adenine – Thymine, Guanine – Cytosine) are well defined.
- In one turn of the DNA, 10 pairs of base are seen.

Size 12.5x35 cm

9982-1005300

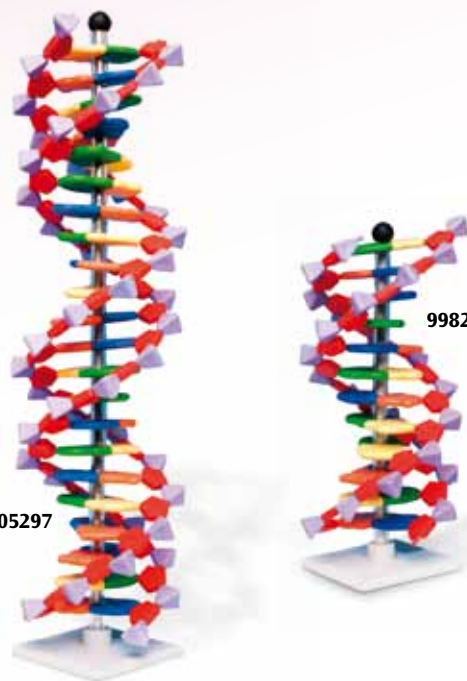

9982-1005297

9982-1005298

This right handed double helix self assembly kit with 12/22 (½ turns) base pairs can be used to model DNA REPLICATION and complementary base pairing. It contains colour coded parts to represent the nitrogenous bases, pentose sugars and phosphate components that make up DNA. Special features:

- Connected by 2 and 3 Hydrogen bonds for Thymine/Adenine and Cytosine/Guanine respectively
- Clearly demonstrating the major and minor grooves
- Differently sized pyrimidines to purines

Delivered with instructions and stand.

Advanced miniDNA™ (22 layer)

Contents: 11 Thymine (orange), 11 Adenine (blue), 11 Guanine (green), 11 Cytosine (yellow), 44 Deoxyribose (red), 44 Phosphate (purple).
17x23.5x6 cm; 0.7 kg

9982-1005297

Advanced miniDNA™ (12 layer)

Contents: 6 Thymine (orange), 6 Adenine (blue), 6 Guanine (green), 6 Cytosine (yellow), 24 Deoxyribose (red), 24 Phosphate (purple)
17x23.5x3 cm; 0.5 kg

9982-1005298

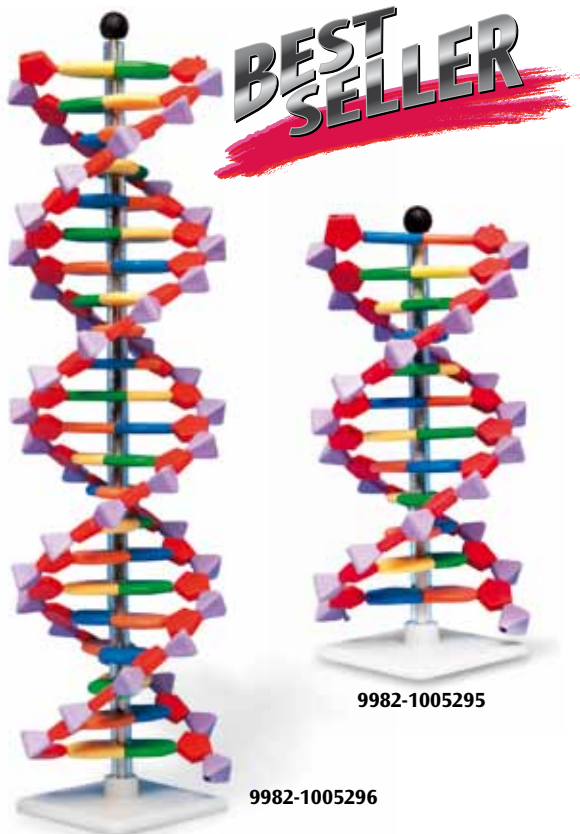

BEST SELLER

9982-1005295

9982-1005296

miniDNA™ 22 Layer Molecular Model

The miniDNA™ system comprises abstract shaped colour coded parts to represent the nitrogenous bases, pentagonal sugar and pyramidal phosphate parts required to make the Double helix model of DNA.

Contents:

- 11 Thymine (orange)
- 11 Adenine (blue)
- 11 Guanine (green)
- 11 Cytosine (yellow)
- 44 Deoxyribose (red)
- 44 Phosphate (purple)

Supplied with assembly instructions and its own stand. Packed in a plastic box.

44 cm; diam 11 cm

📖 E

9982-1005296

miniDNA™ 12 Layer Molecular Model

The miniDNA™ system comprises abstract shaped colour coded parts to represent the nitrogenous bases, pentagonal sugar and pyramidal phosphate parts required to make the Double helix model of DNA.

Contents:

- 6 Thymine (orange)
- 6 Adenine (blue)
- 6 Guanine (green)
- 6 Cytosine (yellow)
- 24 Deoxyribose (red)
- 24 Phosphate (purple)

Supplied with assembly instructions and its own stand. Packed in a plastic box.

24 cm; diam. 11 cm

📖 E

9982-1005295

NEW

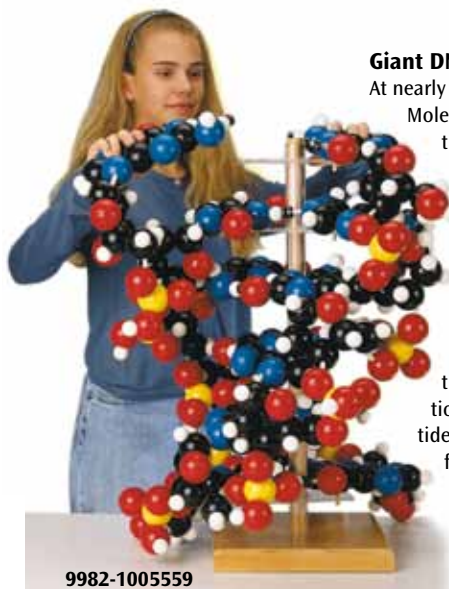

9982-1005559

Giant DNA Model

At nearly 90 cm in height, this DNA Molecule is ideally suited to the classroom environment. Magnetic connectors, representing hydrogen bonds, permit the two strands of the double helix to unzip completely, evoking the mechanism of DNA replication, and RNA synthesis (genetic transcription). Removable nucleotides let students experience first hand why a larger purine base must always pair with a smaller pyrimidine base, and that base pairs are complementary –

adenine pairing with thymine and guanine pairing with cytosine. Non-separable atoms connected by permanent flexible “bonds” form the sugar-phosphate backbone of the molecule. Encompassing six base pairs the double helix is mounted on a wooden base and can be rotated.

86x41 cm; 8.0 kg

E

9982-1005559



9982-1005299

**Advanced miniDNA™
12 Base RNA**

Easily assemble this single strand molecule which consists of the 4 bases, as in DNA, and Uracil. This kit contains 12 bases, equivalent to 4 codons in a single strand model of messenger RNA as well as 2 “clover leaf” shaped Transfer RNA parts and 2 amino-acid parts. Together with the 12 layer Advanced miniDNA™ kit it can be used to model the creation of RNA by transcription. Furthermore, it provides hands-on investigation into protein synthesis known as translation.

Contents:

- 3 Uracil (light blue)
- 3 Adenine (blue)
- 3 Guanine (green)
- 3 Cytosine (yellow)
- 12 Ribose (red)
- 12 Phosphate (purple)

E

9982-1005299

Nucleic Acid Building Blocks

Coloured units (representing phosphoric acids, purines and pyrimidines) for constructing DNA, t-RNA and RNA helices. Also useful for explaining replication and transcription.

31.5x24x5 cm; 1 kg

E

9982-1005127



9982-1005127



9982-1005302



9982-1005128

DNA-RNA

The small DNA-RNA model shows the double helix and how the molecules split at the centre of the base pairs.

Items:

- 28 coloured tubes (Guanine red, Cytosine green, Thymine blue, Adenine grey)
- 12 white two prong centre, which represents the hydrogen bond between the base pairs
- 28 black trigonal atom centres which represent sugar
- 25 red two prong atom centres, which represent phosphate groups
- 50 yellow tubes that link the phosphate groups to the sugar rings
- Wooden base with support rod are included in the kit

Height: 50 cm

20x30x0.5 cm; 0.1 kg

E

9982-1005302

DNA Double Helix

3 coils of the DNA double helix, consisting of nucleic acids, to demonstrate base pairing. At the top end is attached one RNA cord, to show the basis of transcription.

On base.

31x9x9 cm; 0.2 kg

E

9982-1005128

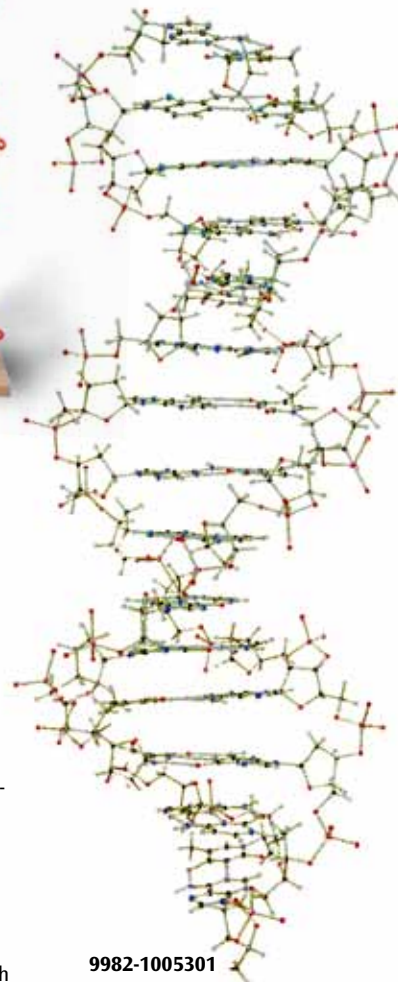

9982-1005301

Minit Preview DNA model

This detailed teaching model uses coloured atoms and bonds to help pupils understand the chemical structure of DNA. Students can work in groups to create and study the subassemblies: Thymine-Adenine; Cytosine-Guanine, sugar rings and phosphate groups which can then be brought together to make the finished model – nearly 1m high (width 30 cm). 15 base pairs show more than one turn of the double helix and major and minor grooves and illustrate the chemical composition and types of bonding. The model hangs between two plates from clear strings and can be supported by an optional display stand.

Contents:

880 atoms, 1,200 bonds, support plates for hanging, assembly instructions and worksheet in English.

9982-1005301

Structure & Function of DNA

Chemical Principles

Research Molecular Construction Set

Consisting of 303 atoms, 34 caps and 100 locking pins, this set can be used to build such structures as:

- DNA
- RNA
- Amino acids
- Polypeptides
- Terpenes
- Steroids
- Alkaloids
- All structures from introductory and advanced set

 E

9982-1005048



9982-1005048



9982-1005290

Organic (Teacher) Set

111-atom parts – Open and Compact Models. This set enables the teacher to demonstrate the key areas of Organic chemistry, including all the functional groups, alkanes, alkene, alkynes, alkylhalides, alcohols, ethers, aldehydes, ketones, carboxylic acids, nitriles, amines, esters, aromatic and heterocyclics. Structural isomerism and stereoisomerism (e.g. optical and geometric) and conformational analysis. Examples: isoprene, lactic acid, glucose, P.V.C., trichlorophenol, alanine, caffeine, saccharine, aspirin, menthol, benzene, ionone, humulone, adreniline, penicillin, and aromotherapy courses.

Contents:

- 24 Carbon, black, tetrahedral
- 6 Carbon, black, trigonal
- 2 Carbon, black, linear
- 6 Carbon, black, tribipyramidal
- 40 Hydrogen, white
- 12 Oxygen, red, angular
- 4 Nitrogen, blue, tetrahedral
- 1 Sulphur, yellow, tetrahedral
- 1 Sulphur, yellow, angular
- 4 Phosphorus, purple, tetrahedral
- 8 Halogen, green
- 2 Metal, grey
- 1 Metal, grey, 2 holes
- 55 Links, grey, medium
- 25 Links, grey, long flexible
- 60 Links, white, short
- 1 Tool

 E

9982-1005278



9982-1005278

Organic Student Set

Each Student Set comes with an instruction leaflet and is packed in a four-compartmented box. The Student Sets are designed for school, college or self study chemistry courses. Sufficient links are provided to make single, double, and triple bonds for OPEN and short links for CLOSED models. The models can easily be assembled and reassembled to make hundreds of possible structures.

- 50 atom-parts
- 12 Carbon, 4-holes tetra, black
- 6 Oxygen, 2-holes ang., red
- 20 Hydrogen, 1-hole, white
- 4 Nitrogen, 4-holes tetra, blue
- 1 Sulphur, 4-holes tetra, yellow
- 1 Sulphur, 6-holes octa, yellow
- 1 Phosphorus, 4-holes, purple
- 4 Halogen, 1-hole, green, 17mm
- 1 Metal, 1-hole, grey, 17mm
- 26 links, grey, medium ML-12
- 12 links, grey, flexible long ML-13
- 26 links, white, short ML-10
- 1 link remover tool

9982-1005290

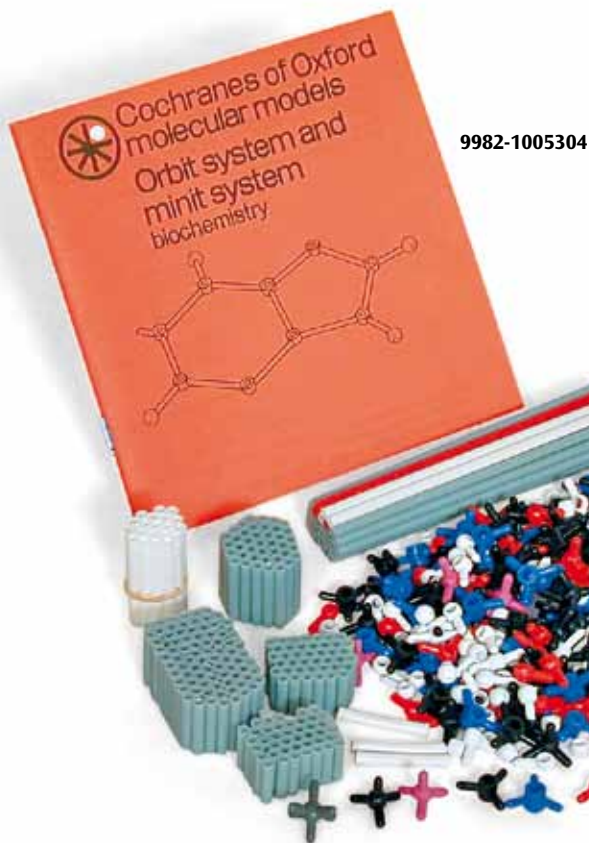

9982-1005304

Student-Set – Biochemistry

This set comprises 255 atom centres, scale 3cm = 100pm. The centres are colour coded according to the element and the bond angles are marked. Bonds between atoms are made from plastic straws, which can be cut to any required length. The items consist of: Amino acids, monosaccharides, glycerol, fatty acids, steroids, purines and pyrimidines, peptides, disaccharides, lipids, nucleosides, nucleotides, proteins, polysaccharides, nucleic acids.

15x20x2 cm; 0.2 kg

E

9982-1005304

Amino Acid 7 Model Collection Kit

(Including peptide bond upgrade)

The following amino acids can be assembled. Group 1 Valine, Group 2 Threonine, Group 3 Phenylalanine, Group 4 Methionine, Group 5 Histidine, Group 6 Aspartic acid, Group 7 Glutamine and Proline. Extra parts are included to form peptide bonds and hydrogen bonds to make a polypeptide chain and part of a beta-pleated sheet contents:

- 24 Carbon black
- 19 Carbon black
- 77 Hydrogen white
- 10 Oxygen red – angular
- 10 Oxygen red – linear
- 1 Sulphur yellow
- 1 Nitrogen blue
- 9 Nitrogen blue trigonal
- 1 Nitrogen blue angular
- 8 Hydrogen
- 90 NV-links
- 2 Short link remover tools

E

9982-1005288



9982-1005287

Fat (Glyceryl Tristearate)

Contents:

- 54 Carbon black
- 3 Carbon black
- 3 Oxygen red
- 3 Oxygen red
- 110 Hydrogen white
- 65 Links short
- 1 Short Link remover tool

E

9982-1005287



9982-1005289

Alpha-Helix (15 peptide units)

Contents:

- 15 Carbon black
- 15 Hydrogen white
- 15 Group "R" green
- 15 Carbon black
- 15 Nitrogen blue
- 15 Oxygen red
- 15 Hydrogen white
- 75 Link colourless
- 1 Short Link remover tool

E

9982-1005289

Glucose Kit 2 Molecules

Contents:

- 12 Carbon black
- 12 Oxygen red
- 24 Hydrogen white
- 48 Short link NV
- 1 Short link extractor tool

E

9982-1005286

9982-1005286

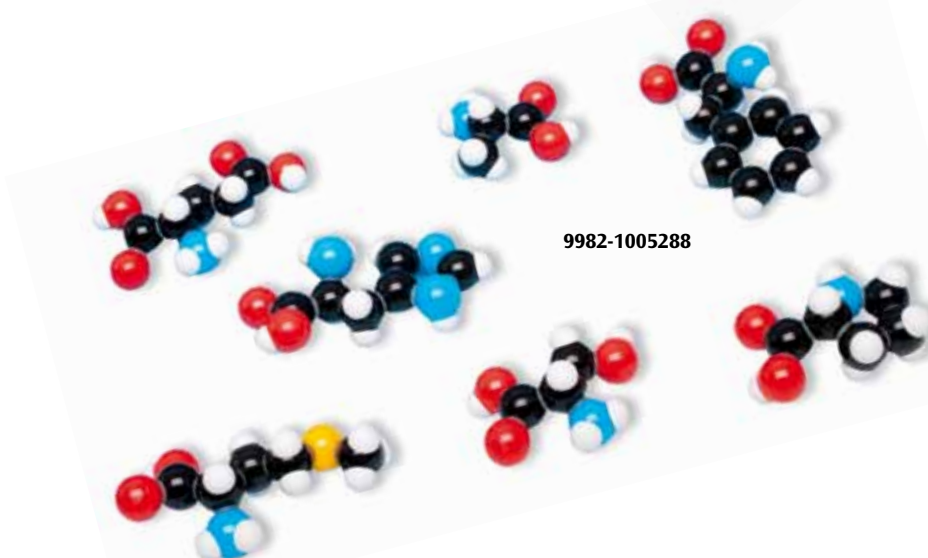

9982-1005288



9982-1005280

Biochemistry (Teacher) Set – Compact Models

257 atom parts compact/semi-spacefilling models. A set for making compact/semi space-filling models featuring the “mushroom style” hydrogen atom link part. Covering a wide range of biochemical structures. Examples: Structures include, amino-acids, monosaccharides, fatty acids, glycerol, steroids, purines, and pyrimidines, peptides, disaccharides, nucleosides, nucleotides, coenzymes, proteins, polysaccharides, and nucleic acids.

Contents:

- 42 Carbon, black, tetrahedral
- 24 Carbon, black, trigonal.
- 2 Carbon, black, linear
- 12 Nitrogen, blue, tetrahedral
- 12 Nitrogen, blue, trigonal
- 10 Nitrogen, blue, angular
- 20 Oxygen, red, angular
- 10 Oxygen, red, linear
- 10 Oxygen, red
- 10 Hydrogen, white, linear
- 2 Sulphur, yellow, angular
- 6 Phosphorus, purple, tetrahedral
- 1 Metal, grey, tetrahedral
- 1 Metal, grey, octahedral
- 100 Hydrogen, white, atom-link
- 150 NV-links
- 10 V-links, grey
- 2 link remover tools, cream

📖 E

9982-1005280



9982-1005303

Class-Set – Biochemistry

This set comprises 390 atom centres, scale 3 cm = 100 pm. The centres are colour coded according to the element and the bond angles are marked.

Bonds between atoms are made from plastic straws, which can be cut to any required length.

The items consist of:

Amino acids, monosaccharides, glycerol, fatty acids, steroids, purines and pyrimidines, peptides, disaccharides, lipids, nucleosides, nucleotides, proteins, polysaccharides, nucleic acids.

30x20x3 cm; 0.3 kg

📖 E

9982-1005303

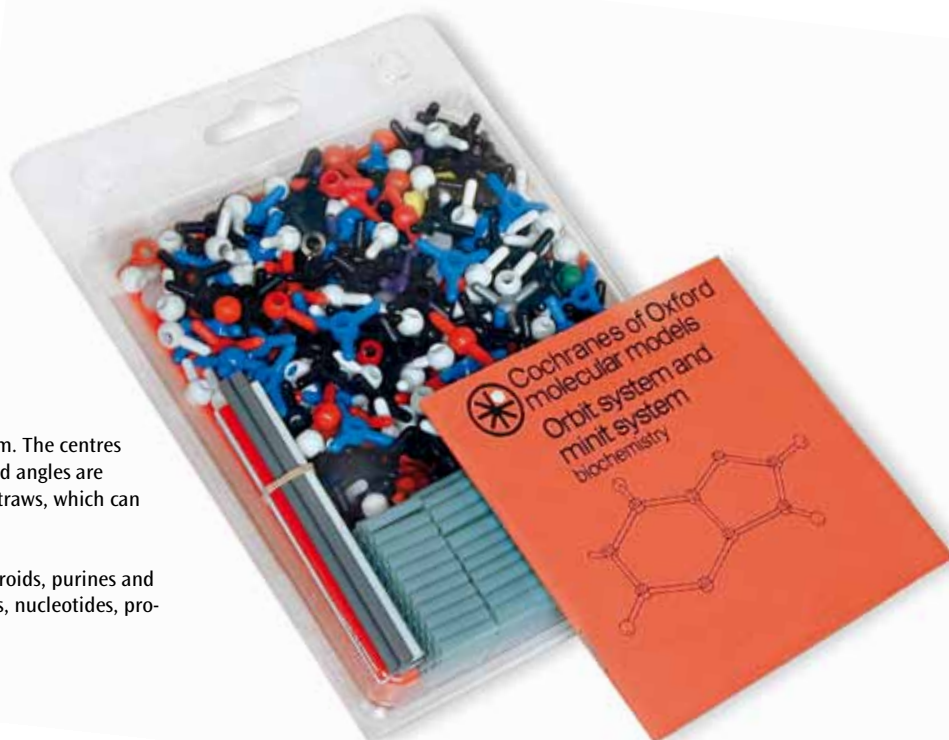

9982-1005305

Student-Set – Biochemistry

This set comprises 255 atom centres, scale 3cm = 100pm. The centres are colour coded according to the element and the bond angles are marked. Bonds between atoms are made from plastic straws, which can be cut to any required length.

The items consist of:

Amino acids, monosaccharides, glycerol, fatty acids, steroids, purines and pyrimidines, peptides, disaccharides, lipids, nucleosides, nucleotides, proteins, polysaccharides, nucleic acids.

15x20x2 cm; 0.2 kg

📖 E

9982-1005305

NEW

Your BLS Simulator for Realistic Training

Basic Billy was developed using the results of a study* on depth of force and compression during cardiopulmonary resuscitation. This enabled optimal force and compression values for adults and children to be determined statistically and then precisely implemented in the product design.

* Robert Sutton et al., *Methods for Determining Paediatric Thoracic Force-Deflection Characteristics from Cardiopulmonary Resuscitation*, *Stapp Car Crash Journal*, Vol. 52 (Nov. 2008), pp. 83-105



9982-1012793

BLS

- Easy to use
- Realistic and Robust
- Adult and Child

Basic Life Support Simulator "Basic Billy"

Cardiovascular failure is one of the most common causes of death. The guidelines issued by the AHA (American Heart Association) and ERC (European Resuscitation Council) show that is not all that difficult to provide help and save lives using the correct cardiac massage and ventilation technique. Of course, Basic Billy fulfils the latest guidelines from the AHA and ERC on cardiopulmonary resuscitation (CPR) and is therefore suitable both for medical training and for first aid training in schools, clubs and first aid courses. You benefit from the following features:

- Torso with shoulders and the necessary anatomical features for finding the ideal pressure point for cardiac massage
- Head with airways for mouth-to-mouth and mouth-to-nose resuscitation
- Head tilt to open the airways
- Mask ventilation is also possible
- Realistic amount of effort and realistic minimum depth of impression with acoustic feedback at 5cm (adult) or 4.5cm (child) using two easy to change springs
- Low priced disposable airways ensure hygienic use and easy care of the mannequin
- The high quality of materials and workmanship guarantee functionality and longevity even under high operational demands
- Developed and manufactured in Germany

Supplied with a transport box (22x61x31 cm³), 2 face masks, 50 disposable airways for adults and children, keycard with adult and child algorithm for the 2010 guidelines and disinfectant.

9982-1012793



MADE IN GERMANY



First Aid



9982-1000341

9982-1000340

Condom Training Model, white skin tone

This model of an erect penis with testicles can be used to learn how to use a condom safely. The anatomical structures and its firmness are absolutely realistic, so that your students can practice putting on and removing a condom in a realistic way. Supplied with 12 dry training condoms and a carrying bag. 7.5x7.5x19.5 cm; 0.35 kg

E/D/S/F/P/I/J www.3BScientific.com

9982-1000340



9982-1005560

Condom Training Model

Demonstrate the proper use of condoms by using this realistic model. Consists of an erect penis, 12 condoms, syringe and artificial semen (UV-fluorescent fluid) to simulate ejaculation. Mounted on a stand with suction cups and delivered with carrying bag. 35.5x15x16.5 cm; 2.3 kg

E

9982-1005560

Condom Training Model, coloured skin tone

Like 9982-1000340

9982-1000341



9982-1005115

Condom Training Models

This economic set consists of 20 Styrofoam penis models, and provides a means of practicing the correct use of condoms, even in large groups. The reusable models can be fixed to the desktop with adhesive tape, so that both hands are free for rolling the condom into position. Supplied without condoms. 14.5 cm

9982-1005115



9982-1000339

Training Model for a Female Condom

This model shows the labia and vagina up to the cervix in a simplified representation for didactic reasons, and is used for demonstrating and learning the insertion of a female condom. Supplied with three Femidom condoms. 12 cm; 0.15 kg

9982-1000339

Dark skin

9982-1000338

Options and Replacements for 9982-1000340, 9982-1000341, 9982-1005115 and 9982-1005560

12 Dry Condoms

9982-4007214

Options and Replacements for 9982-1005560 and 9982-1005784

Artificial Semen

(UV-fluorescent fluid)

9982-1005561



9982-1005825

I.U.D Trainer

This anatomically accurate model represents a section of the uterus, ovaries and fimbriae. The uterus is covered by a clear plastic window to allow easy visualization of insertion and placement of I.U.D. (I.U.D. not included).

E

9982-1005825



9982-1005766

I.U.D Trainer

Hand held trainer which is a suitable aid for understanding correct positioning of I.U.D. (Intrauterine Device) in the uterus. Made of durable plastic, the trainer features a transparent cover which allows easy visualization of insertion and placement of I.U.D. (I.U.D. not included). 6x40x45 cm

E

9982-1005766

Female Condom Model

This model represents an anteverted uterus in a simulated pelvic cavity with soft vulva and vagina and a soft plastic stomach cover. A perfect tool to demonstrate the use of a female condom, contraceptive sponge and cervical cap. Supplied with carrying bag. 17.8x24x14 cm

E

9982-1005826



9982-1005826



9982-1005784

Family Planning Educator

Desktop simulator for training and demonstration of:

- Introduction and removal of a diaphragm, an IUD or sponge contraceptive devices
- Normal and abnormal uterine positions
- Bi-manual examination technique

Supplied with:

- One anteverted uterus with clear upper half to illustrate correct position of IUD
- One uterus to illustrate normal anteversion and retroversion
- Cervix with patent os attaches to uterus suspended within pelvic cavity
- Soft plastic stomach cover
- Carrying bag

25.4x25.4x25.4 cm; 2.3 kg

E

9982-1005784

Contraceptive Case

Graphic teaching material for sex education in schools, out of school youth employment and adult education. The contraceptive case was designed and developed from practical experience. It is suitable for educating about current contraceptives. Replacement teaching material can be ordered at any time.

The contraceptive case contains the following items:

- Condom
- Steroper penis
- Diaphragm, gel, applicator
- Cervical cap
- Intrauterine device
- Sample packages of pills
- Tables for temperature methods
- "Nuvaring"

The components of the contraceptive case can deviate from the list on delivery because individual visual aids can be updated or replaced by other products.

45x32x11 cm

9982-1002385



9982-1002385

Options for 9982-1002385

Plastic Speculum

9982-1004949

Material for Menstruation Hygiene

9982-1004950

Intrauterine Device (not shown)

9982-1008817



9982-1004949



9982-1004950



9982-1000336



AIDS Virus

This model of the HI-Virus, enlarged millions of times, shows the outer lipid membrane with protein structures, and the internal nucleus which contains the viral hereditary matter (RNA). The nucleus is removable and condoms can be put underneath to provide a message regarding measures to take in protecting against HIV. Delivered without condoms. Mounted on base.

18x13x13 cm; 0.7 kg

9982-1000336

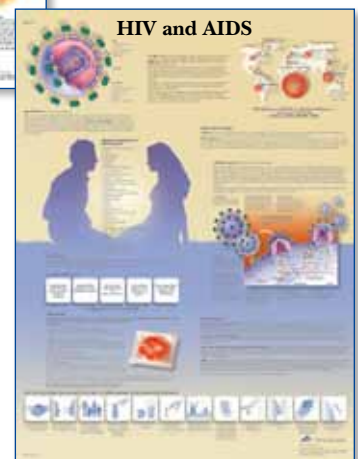

Look for our large selection of Charts starting on page 154.

The Consequences of Smoking – 3D Display

Show the consequences of smoking on various organs of the body with life-sized, hand painted models. Each model is permanently mounted in a carrying case display, and the accompanying text clearly communicates its health message in simple terms. Ideal for health fairs, schools, hospitals, smoking cessation programs, or the workplace. Dimensions when opened: 71x67 cm.

71x34 cm; 8.3 kg

9982-1005580



9982-1005580



9982-1005932

Effects of Smoking Activity Model

Graphically demonstrate the impact of smoking on the lungs. Give your students a first hand view of how tar and other pollutants accumulate in the lungs during smoking. Simply place a lit cigarette in the mouth of the "Smoking Man" and draw smoke into his "lungs" using the syringe pump included. The results will amaze you as you watch his lungs start to darken after only a few short puffs! Includes detailed teacher and student guides that provide extensive background information on the dangers of smoking.

13x10x23 cm; 1 kg

E

9982-1005932



9982-1005565

Smokey Sue – The Dangers of Smoking

Smokey Sue dramatically demonstrates the quantity of tar collected in the lungs when one single cigarette is smoked. The tar, normally inhaled directly into the lung, is collected in a transparent tube, and thus shows the quantity of tar which reaches the lung with each cigarette very clearly. Delivered with stand, 3 collection tubes, and carrying bag.

15x36x17 cm; 1 kg

E

9982-1005565

Tobacco Mouth

This hinged model of the teeth, flexible tongue and oral cavity shows the effects of smokeless tobacco. Mounted on base, supplied with a bottle of simulated tobacco juice.

15x20x10 cm

E

9982-1005566



9982-1005566



9982-1005578

Smoker Model

This small hand-held model actually smokes a cigarette and collects its tars and nicotine on a photo of a real chest X-ray of a lung cancer victim. Stained prints fit into plastic bags, keeping stains intact when they are passed around for closer inspection.

13x29x6 cm

E

9982-1005577



9982-1005577

A Year's Worth of Tar

This graphic, sealed exhibit, containing a pack of cigarettes and cigarette butts submerged in goopy tar, represents the amount of carcinogenic liquid a one-pack-a-day smoker put into his/her lungs over the course of a year.

13x14x8 cm

E

9982-1005578



The Consequences of Alcohol Abuse – 3D Display

This display shows what actually happens to organs of the body when alcohol is abused. Permanently mounted life-size, hand painted models are graphic and accurate. Each model is described in easy-to-understand terms. Contained within its own sturdy wooden carrying case. Dimensions when opened: 71x67 cm.

71x34 cm; 8.3 kg

9982-1005582



9982-1005582

Drunk and Dangerous Glasses

This teaching tool will give any alcohol education program an added dimension, allowing the instructor to deliver a powerful message quickly and clearly. Drinking and driving can be a deadly combination – a thesis graphically demonstrated, especially with young people, through the Drunk and Dangerous glasses. Because the glasses' simulation of drunkenness is so real and intense, wearers can't help but be struck by the reality that alcohol really does make driving dangerous. Supplied with case.

E

9982-1005576



BEST SELLER

9982-1005576

9982-1005583

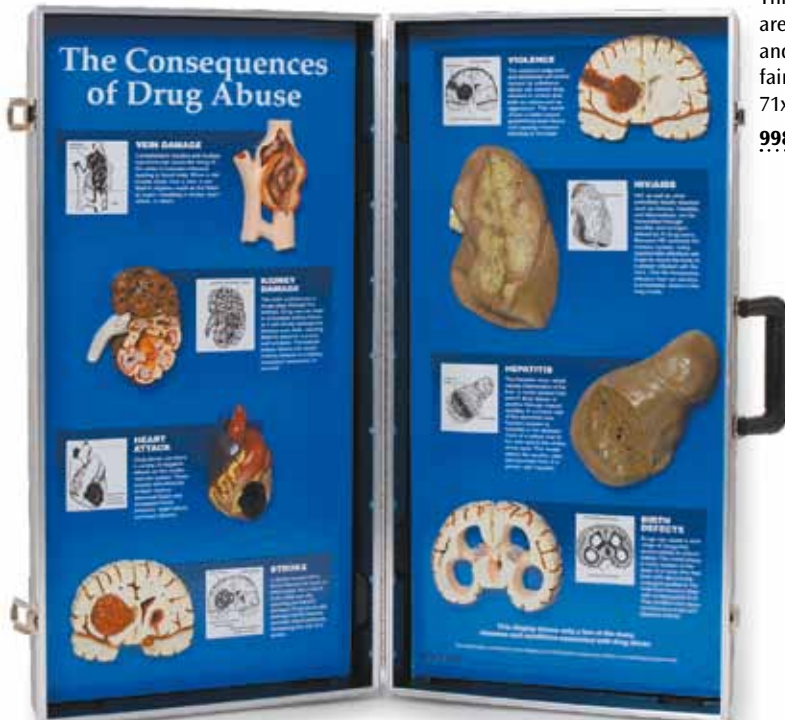

The Consequences of Drug Abuse – 3D Display

This detailed display shows what actually happens to the body when drugs are abused. Life-size, hand painted models of the body's organs are graphic and accurate. Brief descriptions make this educational tool ideal for health fairs and schools. Dimensions when opened: 71x67 cm.

71x34 cm; 8.3 kg

9982-1005583

Look for our large selection of Charts starting on page 154.



6 Model Activity Set of the Body Systems

Includes six model activity sets illustrating the major systems of the human body:

- Circulatory system
- Nervous system
- Respiratory system
- Urinary system
- Digestive system
- Endocrine system

Description in English.

61x45 cm

9982-1005469

**BEST
SELLER**



9982-1005469

In addition, you will receive the following single/individual kits (not shown):

- 9982-1005475 Circulatory System Model Activity Set
- 9982-1005470 Nervous System Model Activity Set
- 9982-1005471 Respiratory System Model Activity Set
- 9982-1005474 Urinary System Model Activity Set
- 9982-1005473 Digestive System Model Activity Set
- 9982-1005472 Endocrine System Model Activity Set
- 9982-1005476 Eye Model Activity Set
- 9982-1005477 Skin Model Activity Set
- 9982-1005478 Teeth Model Activity Set
- 9982-1005479 Ear Model Activity Set
- 9982-1005481 Menstrual Cycle Model Activity Set
- 9982-1005482 Male Reproductive System Model Activity Set
- 9982-1005483 Female Reproductive System Model Activity Set
- 9982-1005489 Germination Cell Model Activity Set

Further Information at:
www.3bscientific.com

9 Model Activity Sets of the Human Reproductive System

Includes:

- Menstrual Cycle
- Male Reproductive System
- Female Reproductive System
- Meiosis
- Mitosis
- Cell to Embryo
- Four-Month Foetus
- Full-term Foetus
- Birth

Description in English.

61x45 cm

E

9982-1005480



9982-1005480

Mitosis Model Activity Set

Illustrate somatic cell division with this informative model. Enlarged views detail five phases of mitosis. Includes: cytoplasm nucleus, nucleolus, chromatic threads, centrioles, aster, spindle, chromosomes and centromere. Description in English. 61x45 cm

E

9982-1005484

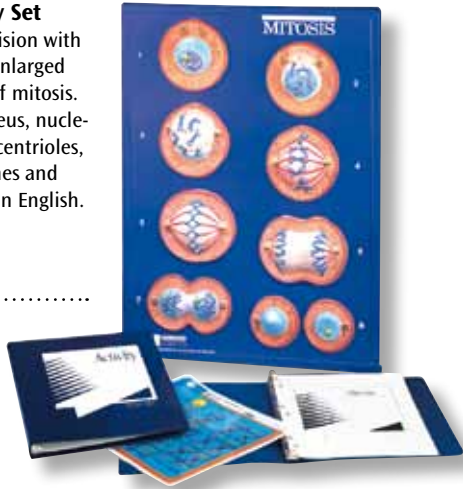

9982-1005484

Meiosis Model Activity Set

Help explain individual human characteristics and genetic differences. Visualization and understanding of meiotic cell division are promoted through enlarged views of chromosomes, cytoplasm and chromatic and polar bodies. Description in English. 61x45 cm

E

9982-1005485



9982-1005485

7 Model Activity Sets Zoology

Introduce students to anatomy with seven dissection models shown in raised relief:

- Crayfish
- Frog
- Earthworm
- Grasshopper
- Perch
- Clam
- Foetal Pig

Each markable model is constructed of durable vinyl and illustrates internal structures in graphic detail. All models are accompanied by a 3-ring notebook which includes teacher's background information, student basic understandings, learner activities, a glossary, colour transparencies, black line master and a key to model structures. Description in English. 61x45 cm

E

9982-1005490



9982-1005490

9982-1005486

9982-1005487

9982-1005488

Plant and Animal Cell Model Activity Set

Students can explore plant and animal cell structure with these 20 cm diameter cell models. Teacher's notebook includes: background information, basic understandings, black line master, two full-colour overhead transparencies, key structure and a glossary.

E

9982-1005486



Also available individually

Plant Cell Model
(without notebook)

9982-1005487

Animal Cell Model
(without notebook)

9982-1005488

Ideal for Teaching, Patient Education and Medical Education!

By popular demand, we have redesigned our 3B Scientific® Charts to make them more versatile. Of course, as always they dynamically illustrate and skillfully describe the most important points of a subject. No one offers more languages and hardly anyone offers a comparable selection of subjects and versions.

And now you can decide what type of chart you want. The black plastic rods with eyelets for hanging ensure the greatest possible flexibility. These practical rods are easy to handle and enable you to affix the charts to the wall easily whilst protecting the charts from damage. Simply order item number 9982-1002372 (2x 50 cm) or 9982-1002373 (2x 98 cm) along with the charts of your choice to receive a complete set for top and bottom. If you prefer a different mode of attachment or wish to use a decorative picture frame, the paper version supplies you with all you need – without any unnecessary frills!

Or would you prefer the laminated deluxe version? It is enhanced with a front and rear 125 micron thick film coating and is already equipped with two metal eyelets for wall attachment. Particularly long lasting, particularly durable, particularly valuable!

The Right Choice for Everyone:

Inexpensive paper version ()*

- For a skilled overview of medical subjects
- With richly detailed illustrations
- For use as a poster or with your own frame

Practical rods for the paper version

9982-1002372 (2x 50 cm), 9982-1002373 (2x 98 cm)

- Ideal for wall attachment
- Very easy to use
- Made of robust and long lasting plastic

*Value preserving laminated deluxe version (**)*

- For heavy duty use
- Can be written on with non-permanent markers
- Can be wiped off anytime
- Good UV resistance
- Environmentally friendly special film coating

All of the versions are printed on 50x67 cm practical poster size high quality 200 g image printing paper (exception: 9982-4006730 Body acupuncture 98x68 cm).

Also available in German, French, Spanish, Italian and Japanese (Japanese in size 30x40 cm). Some products from our range are also available in Brazilian, Portuguese and Russian. Please contact us!

The series is constantly being expanded so you will soon find the anatomical wall charts you need, but haven't seen yet on these pages. If there is a subject you're missing, get in touch with us, we might already be working on it. If not, we always appreciate good ideas.



For quantities of 500 and above per title we can personalise your charts. Please contact us!

Practical rods for the inexpensive paper version 50 cm

9982-1002372

Practical rods for the inexpensive paper version 98 cm

9982-1002373

Laminated deluxe version





9982-4006651 *
 9982-1001468 **

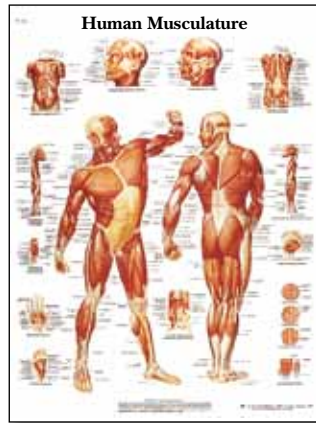

9982-4006652 *
 9982-1001470 **



9982-4006653 *
 9982-1001472 **

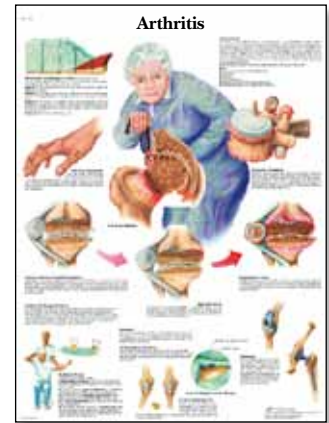

9982-4006654 *
 9982-1001474 **



9982-4006655 *
 9982-1001476 **

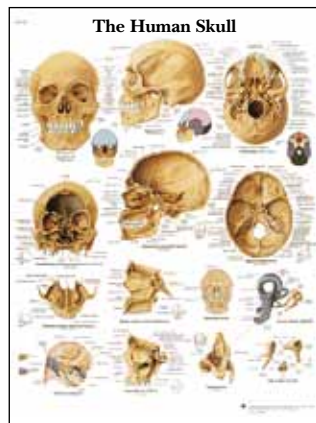

9982-4006656 *
 9982-1001478 **



9982-4006657 *
 9982-1001480 **

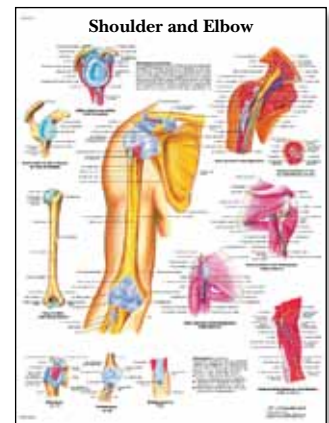

9982-4006658 *
 9982-1001482 **



9982-4006659 *
 9982-1001484 **

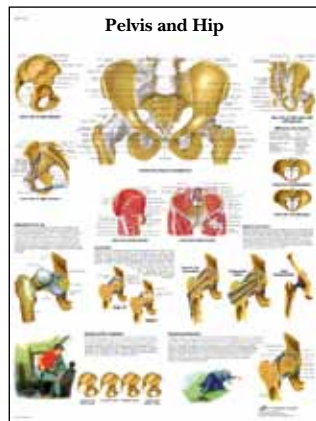

9982-4006660 *
 9982-1001486 **



9982-4006661 *
 9982-1001488 **

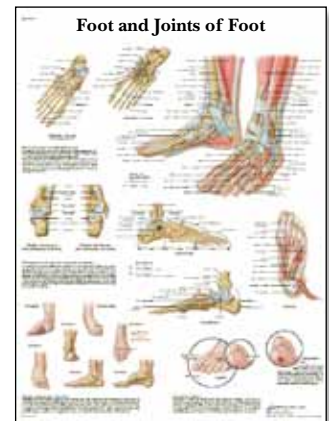

9982-4006662 *
 9982-1001490 **



9982-4006663 *
 9982-1001492 **

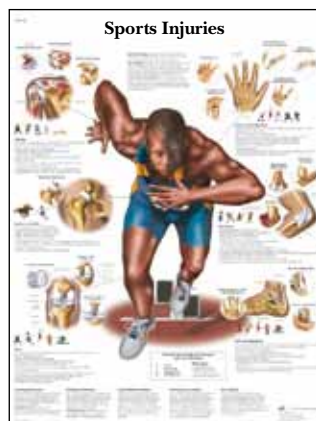

9982-4006664 *
 9982-1001494 **

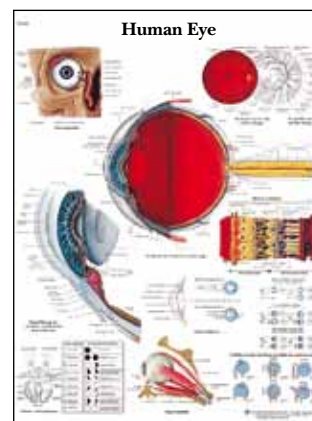

9982-4006665 *
 9982-1001496 **

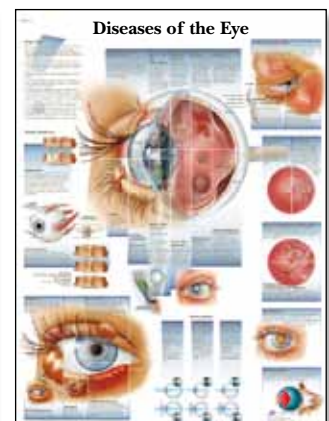

9982-4006666 *
 9982-1001498 **

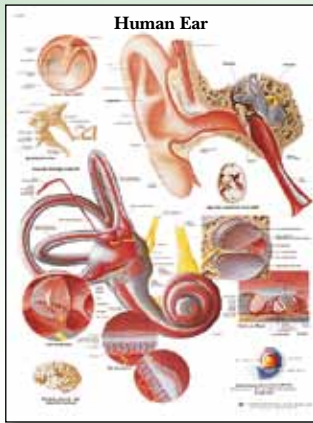

9982-4006667 *
9982-1001500 **



9982-4006668 *
9982-1001502 **

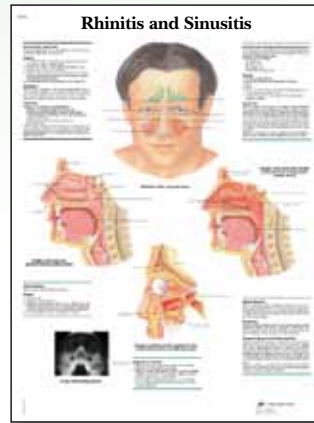

9982-4006669 *
9982-1001504 **



9982-4006670 *
9982-1001506 **



9982-4006671 *
9982-1001508 **

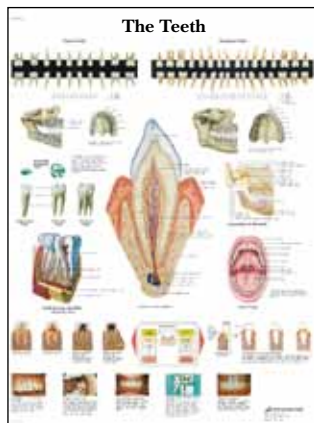

9982-4006672 *
9982-1001510 **

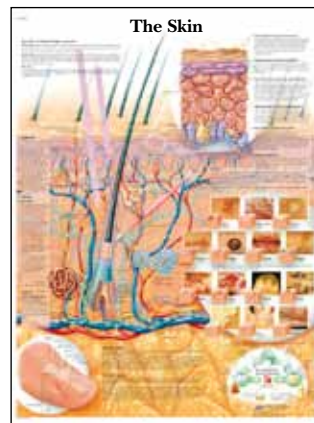

9982-4006673 *
9982-1001512 **



9982-4006674 *
9982-1001514 **

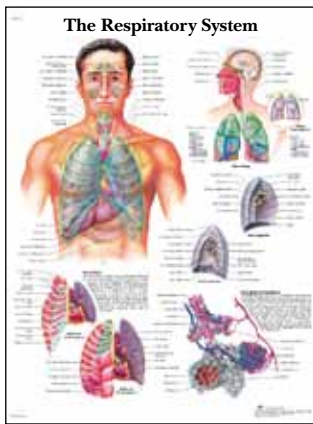

9982-4006675 *
9982-1001516 **

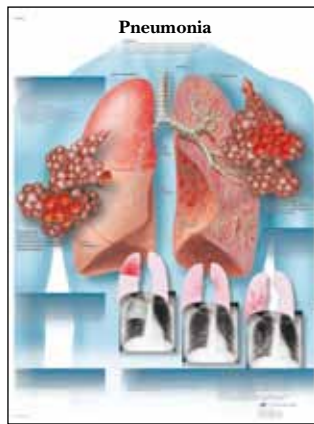

9982-4006676 *
9982-1001518 **



9982-4006677 *
9982-1001520 **

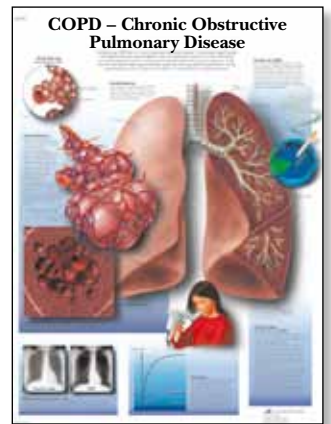

9982-4006678 *
9982-1001522 **

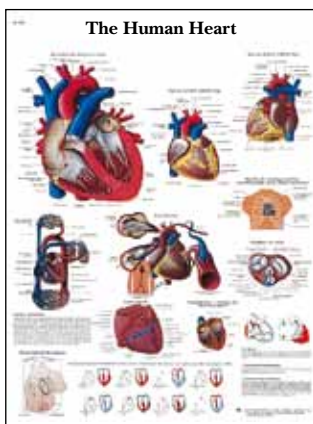

9982-4006679 *
9982-1001524 **

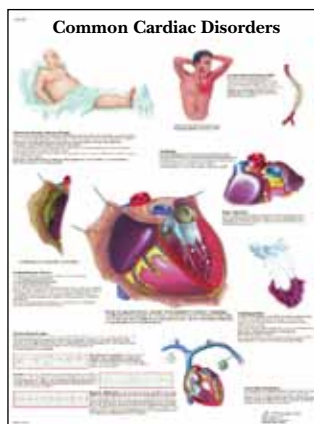

9982-4006680 *
9982-1001526 **



9982-4006681 *
9982-1001528 **

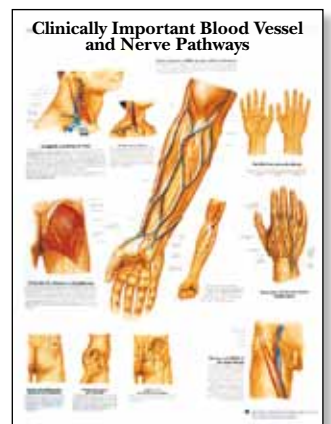

9982-4006682 *
9982-1001530 **



9982-4006683 *
 9982-1001532 **



9982-4006684 *
 9982-1001534 **

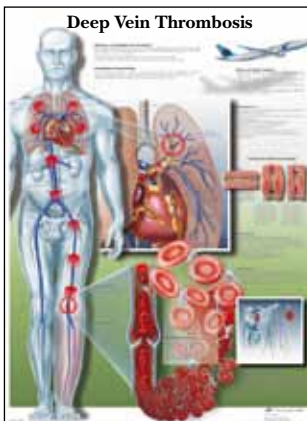

9982-4006685 *
 9982-1001536 **

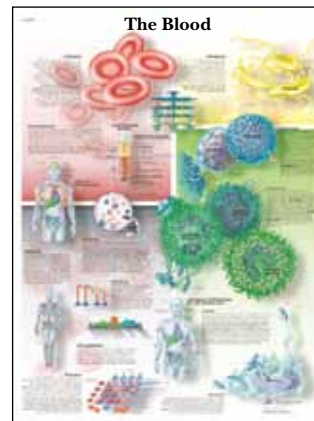

9982-4006686 *
 9982-1001538 **



9982-4006687 *
 9982-1001540 **



9982-4006688 *
 9982-1001542 **

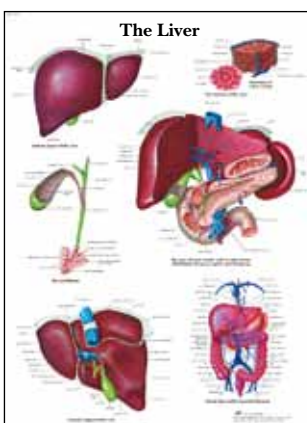

9982-4006689 *
 9982-1001544 **

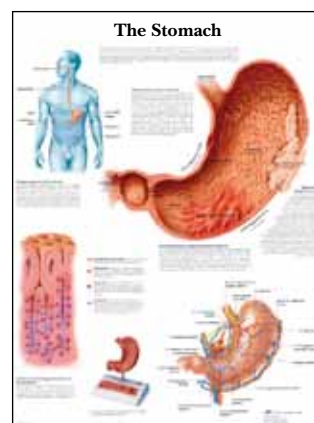

9982-4006690 *
 9982-1001546 **

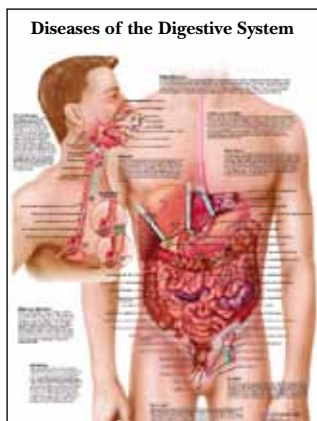

9982-4006691 *
 9982-1001548 **

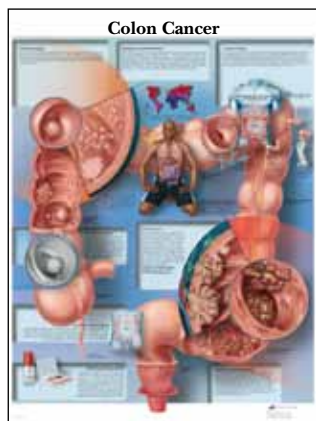

9982-4006692 *
 9982-1001550 **

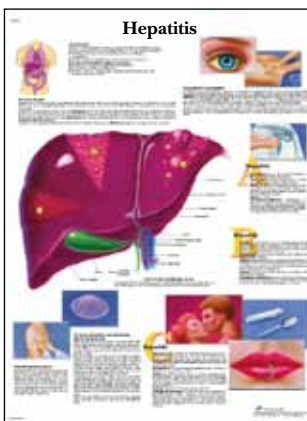

9982-4006693 *
 9982-1001552 **

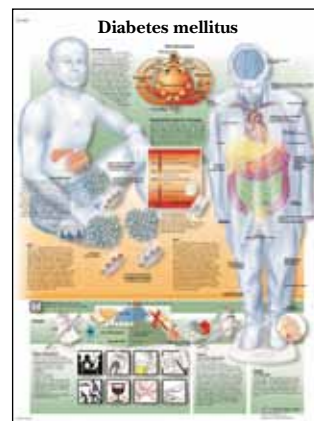

9982-4006694 *
 9982-1001554 **

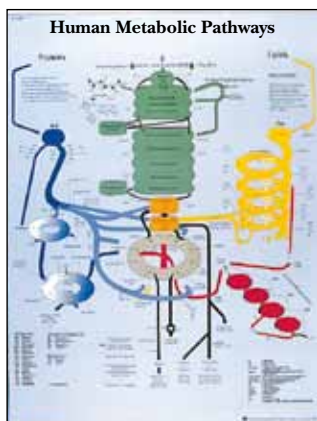

9982-4006695 *
 9982-1001556 **



9982-4006696 *
 9982-1001558 **



9982-4006697 *
 9982-1001560 **

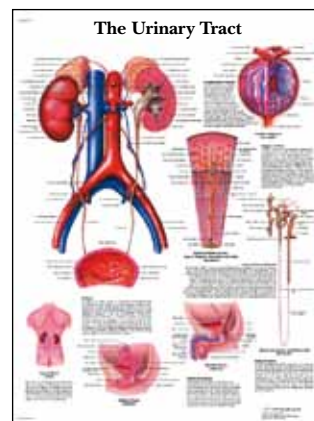

9982-4006698 *
 9982-1001562 **



9982-4006699 *
9982-1001564 **



9982-4006700 *
9982-1001566 **

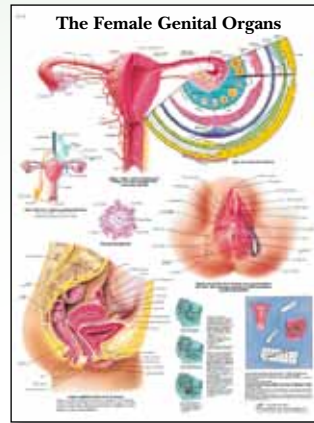

9982-4006701 *
9982-1001568 **



9982-4006702 *
9982-1001570 **

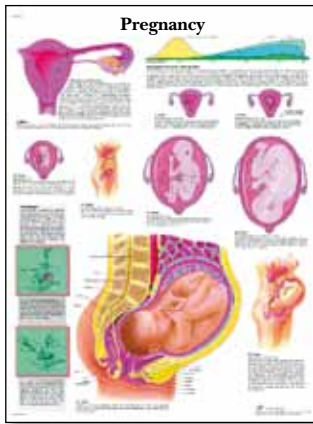

9982-4006703 *
9982-1001572 **



9982-4006704 *
9982-1001574 **

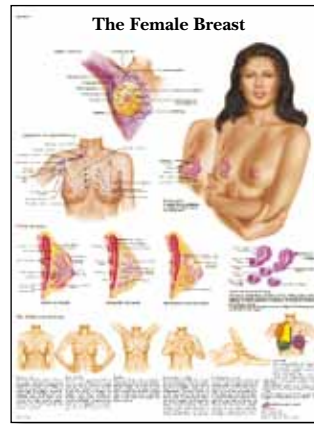

9982-4006705 *
9982-1001576 **



9982-4006706 *
9982-1001578 **



9982-4006707 *
9982-1001580 **



9982-4006708 *
9982-1001582 **

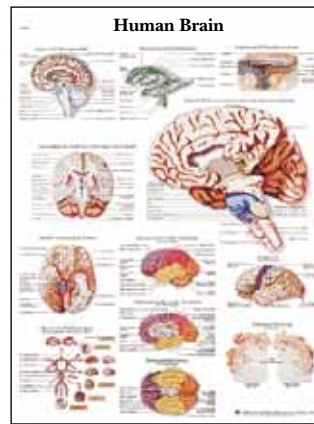

9982-4006709 *
9982-1001584 **



9982-4006710 *
9982-1001586 **



9982-4006711 *
9982-1001588 **

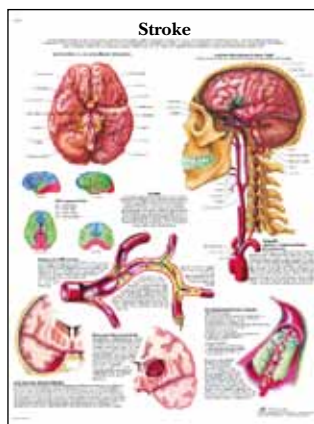

9982-4006712 *
9982-1001590 **



9982-4006713 *
9982-1001592 **

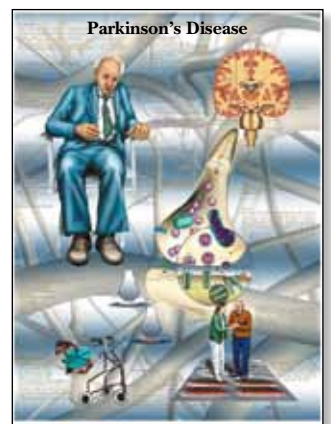

9982-4006714 *
9982-1001594 **



9982-4006715 *
 9982-1001596 **

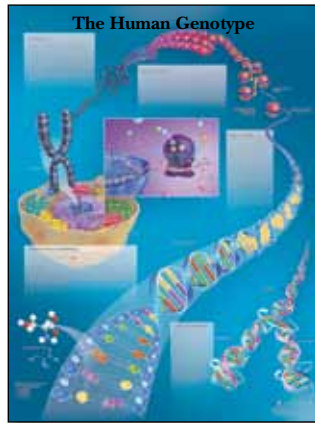

9982-4006717 *
 9982-1001600 **

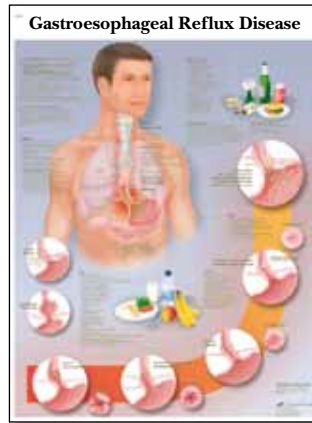

9982-4006718 *
 9982-1001602 **

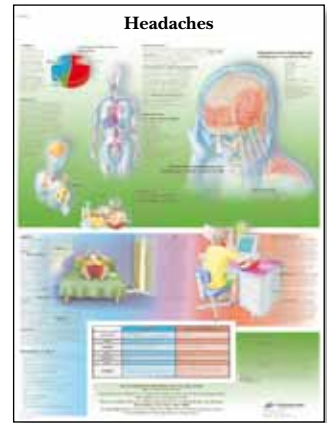

9982-4006719 *
 9982-1001604 **



9982-4006720 *
 9982-1001606 **



9982-4006721 *
 9982-1001608 **

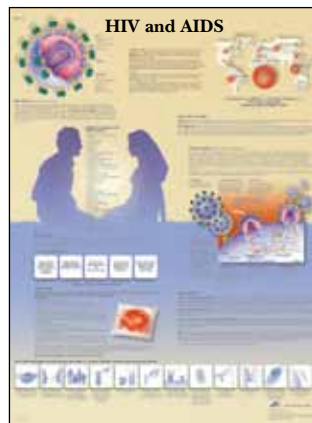

9982-4006722 *
 9982-1001610 **

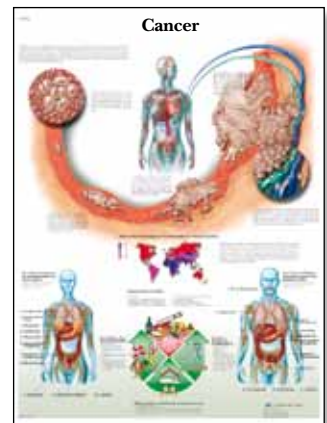

9982-4006723 *
 9982-1001612 **



9982-4006724 *
 9982-1001614 **



9982-4006725 *
 9982-1001616 **



9982-4006726 *
 9982-1001618 **

If there is a subject you're missing, get in touch with us, we might already be working on it. If not, we always appreciate good ideas.



9982-4006727 *
 9982-1001620 **



9982-4006728 *
 9982-1001622 **

15%
 discount on orders
 of 5 or more items

- * Inexpensive paper version
- ** Value preserving laminated deluxe version



9982-4006729 *
9982-1001624 **



9982-4006731 *
9982-1001628 **

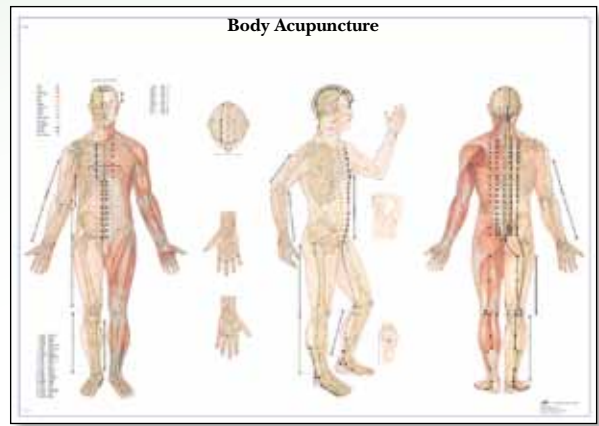

Size: 98x68 cm
9982-4006730 *
9982-1001626 **

For presentation and storage of your charts

Chart Display Stand including including all English anatomical charts (L-versions)

9982-1002381

Practical Chart Display Stand for storage of laminated charts

9982-1002376



9982-1002381
9982-1002376

Anatomical Wall Charts

A valuable educational supplement for schools, universities and medical facilities. These impressive anatomical wall charts are supplied with a detailed six language product manual and scientifically correct nomenclature. They are printed on waterproof, tear resistant paper and are available with (+) or without (-) wooden rods in two different sizes.

Dimensions: 84x118 cm
Dimensions: 84x200 cm

L/E/D/F/S (partially I/P/R/C)

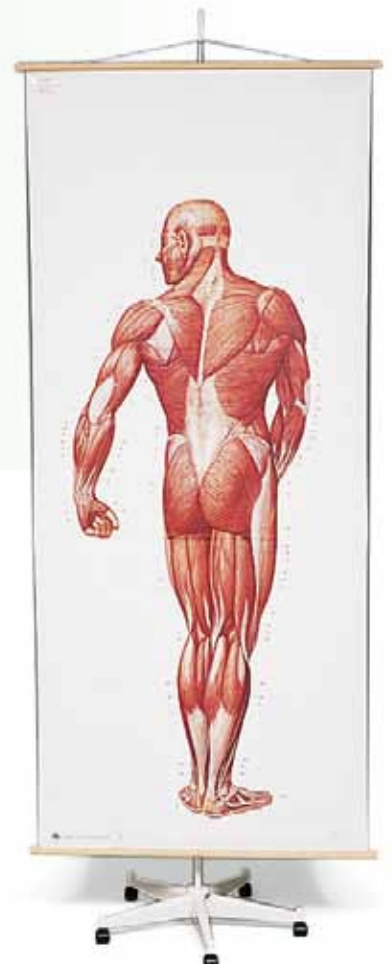

9982-1000520

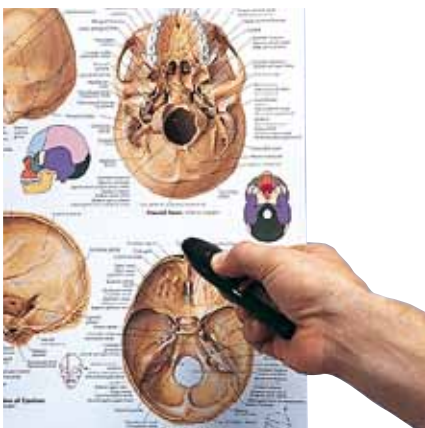

9982-1013170

Special Mobile Stand with Brake

We recommend this helpful stand for displaying the anatomical wall charts.

9982-1000520

Laser Pointer

This safe Laser Pointer (laser safety class II) with its convenient pen shaped design assists your lessons with 3B Scientific® Charts. The red beam spot will stay small and sharp even in daylight and from large distances. A convenient aid for any teacher.

9982-1013170

Charts 50x67 cm / 98x68 cm

The Human Skeleton, front
9982-4006512 –
9982-1001146 +

The Human Skeleton, rear
9982-4006513 –
9982-1000012 +

The Vascular System
9982-4006515 –
9982-1001151 +

The Human Musculature, front
9982-4006514 –
9982-1001149 +

The Human Musculature, rear
9982-4006516 –
9982-1001153 +

The Nervous System, front
9982-4006539 –
9982-1001190 +

The Nervous System, rear
9982-4006540 –
9982-1001192 +

Size: 84x200 cm

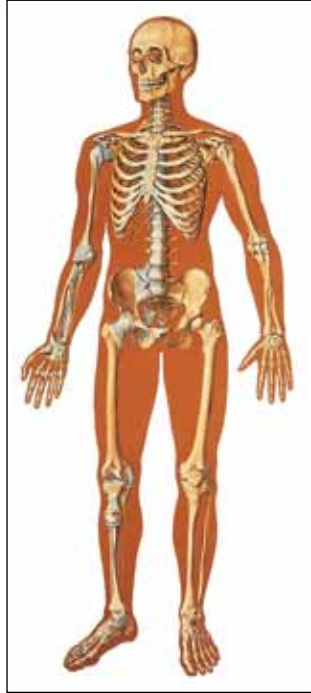

9982-4006512 –
9982-1001146 +

Size: 84x200 cm

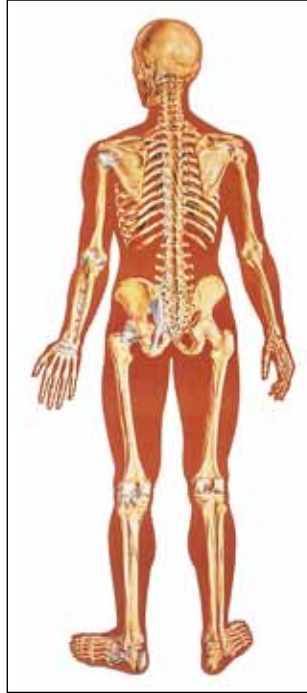

9982-4006513 –
9982-1000012 +

Size: 84x200 cm



9982-4006515 –
9982-1001151 +



9982-4006514 –
9982-1001149 +

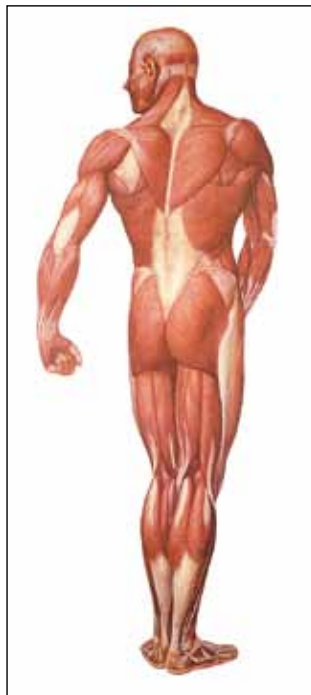

9982-4006516 –
9982-1001153 +



9982-4006539 –
9982-1001190 +



9982-4006540 –
9982-1001192 +

Size: 118x84 cm

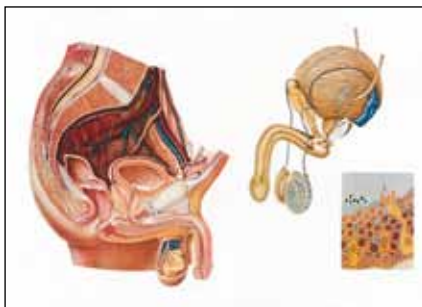

The Male Pelvic Organs
9982-4006527 –
9982-1001173 +

Size: 118x84 cm

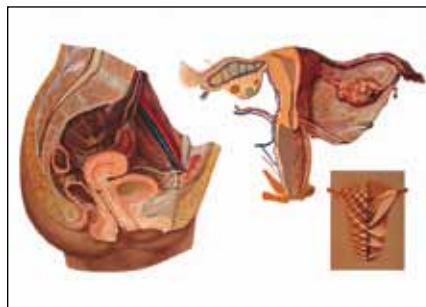

The Female Pelvic Organs
9982-4006528 –
9982-1001175 +

Size: 118x84 cm

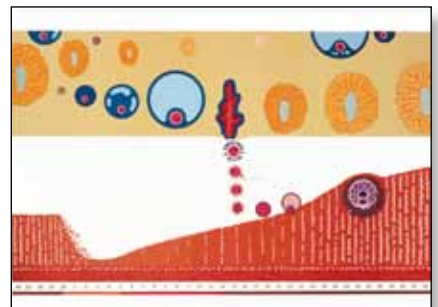

Menstrual Cycle and Ovum Implantation
9982-4006559 –
9982-1001220 +

Large Charts 84x200 cm / 118x84 cm

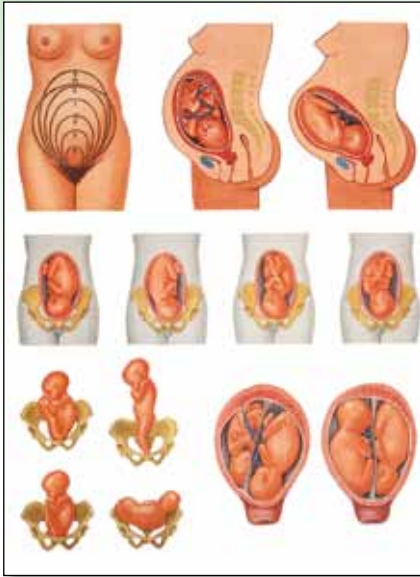

Position of the Child before Birth
 9982-4006562 –
 9982-1001226 +

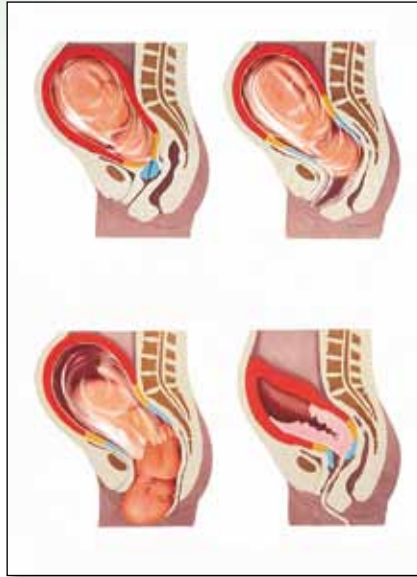

The Birth Process
 9982-4006547 –
 9982-1001204 +

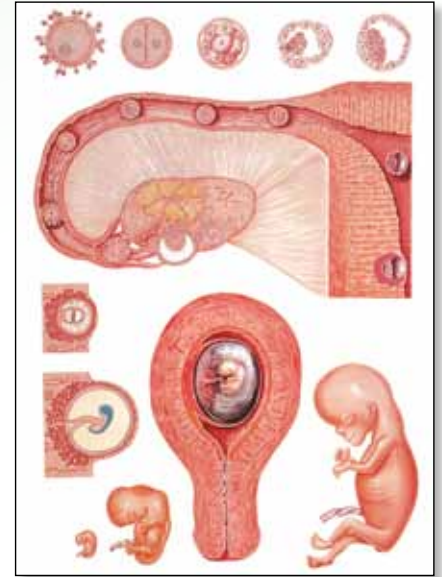

Embryology I
 9982-4006560 –
 9982-1001222 +

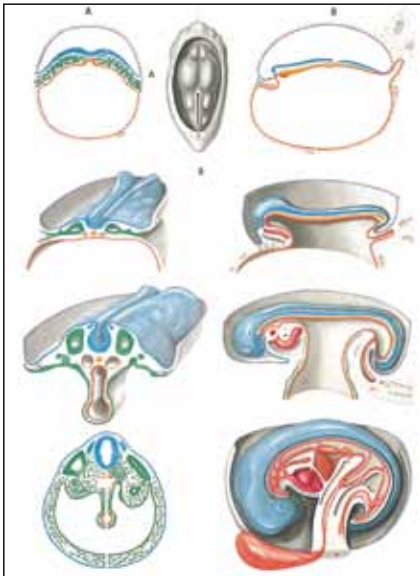

Embryology II
 9982-4006561 –
 9982-1001224 +

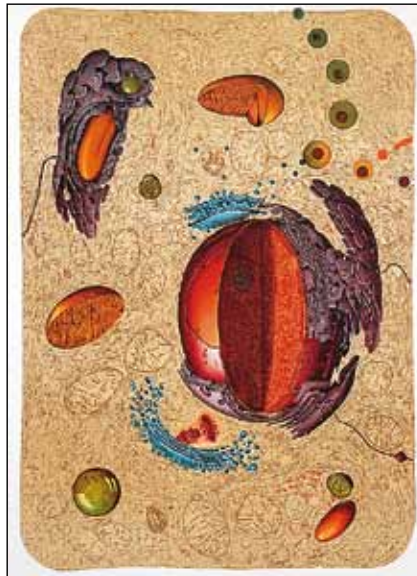

Human Cell Structure
 9982-4006531 –
 9982-1001179 +

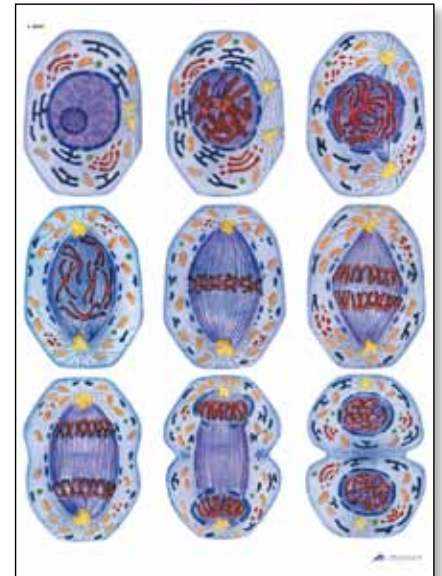

Cell Division I, Mitosis
 9982-4006548 –
 9982-1001206 +

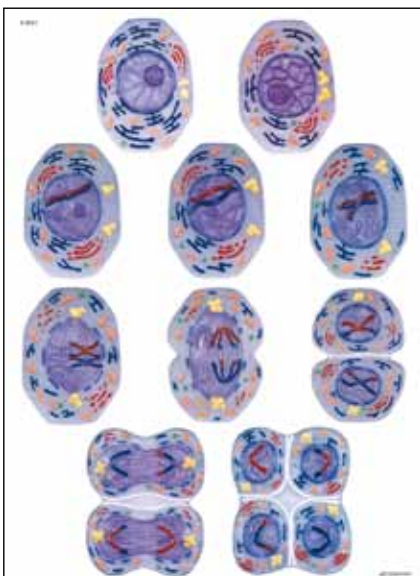

Cell Division II, Meiosis
 9982-4006550 –
 9982-1001210 +

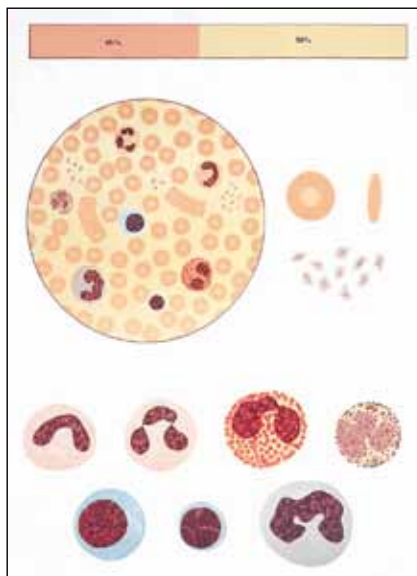

The Blood, Composition
 9982-4006534 –
 9982-1001183 +

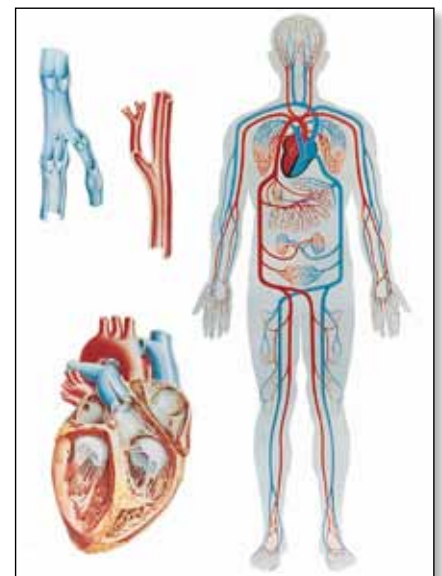

Human Blood Circulation
 9982-4006525 –
 9982-1001169 +



The Skin
9982-4006530 –
9982-1001177 +

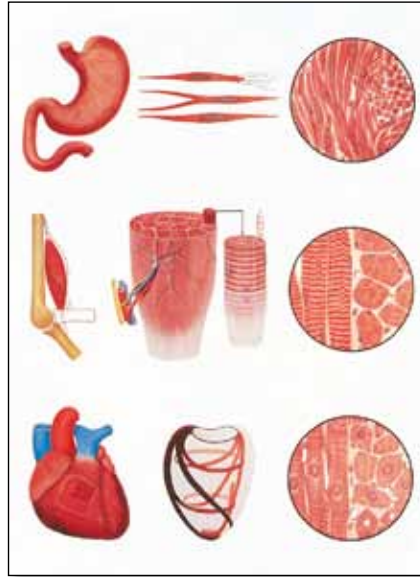

Muscle Tissue
9982-4006551 –
9982-1001212 +



Bone Structure
9982-4006549 –
9982-1001208 +

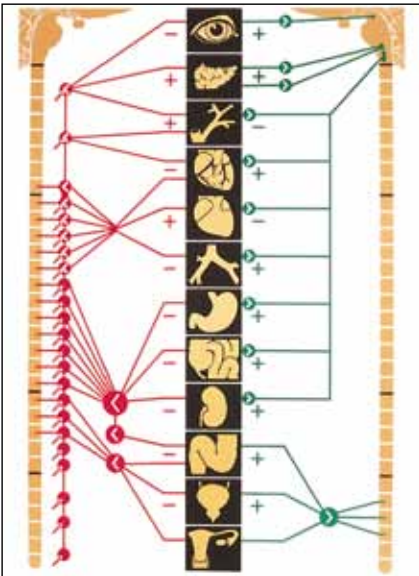

The Vegetative Nervous System
9982-4006556 –
9982-1001218 +

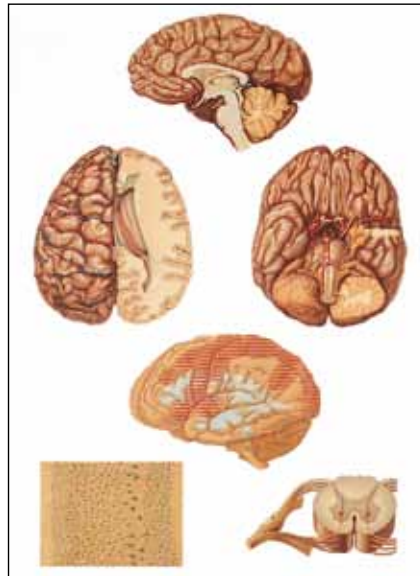

The Human Central Nervous System
9982-4006536 –
9982-1001185 +

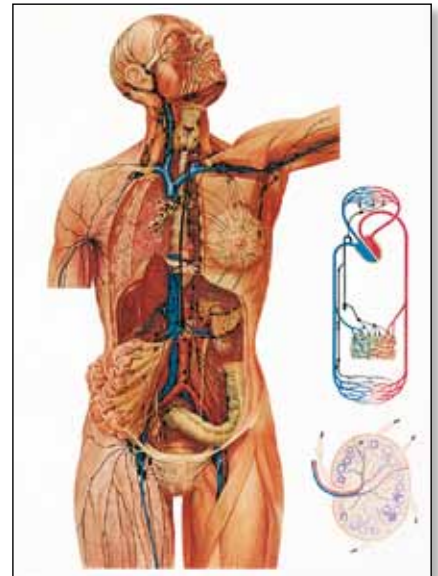

The Lymphatic System
9982-4006553 –
9982-1001216 +



Endocrine Glands
9982-4006545 –
9982-1001200 +

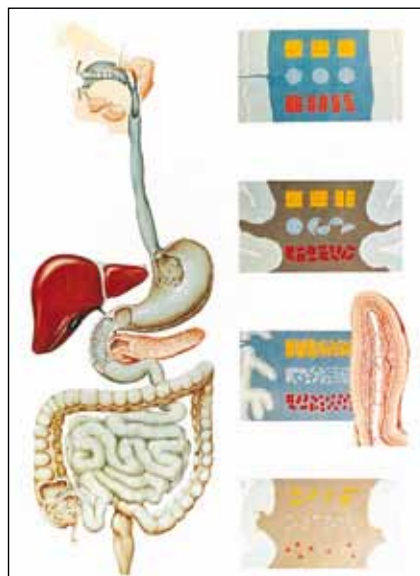

The Digestive System
9982-4006542 –
9982-1001196 +

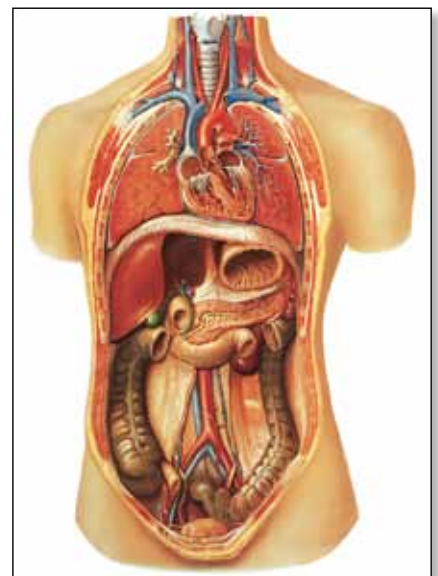

Internal Organs
9982-4006517 –
9982-1001155 +

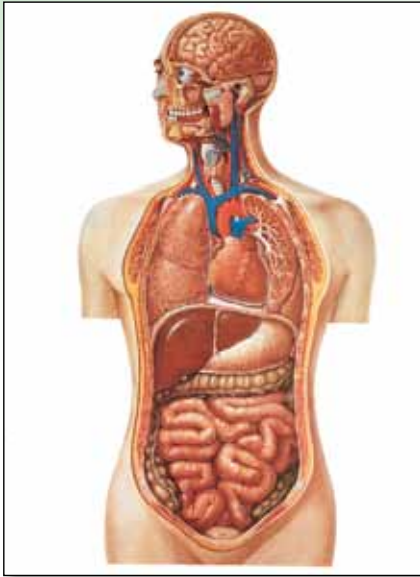

Torso
9982-4006519 –
9982-1001159 +

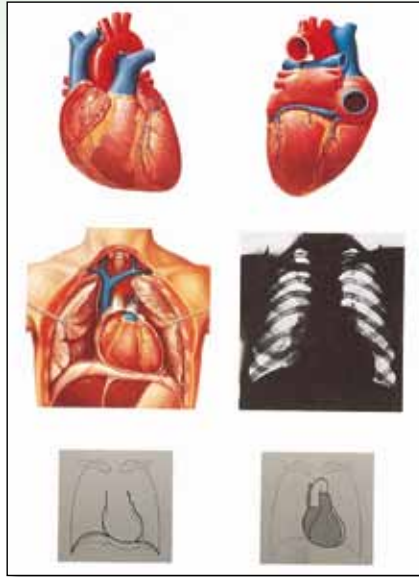

The Heart, Anatomy
9982-4006552 –
9982-1001214 +

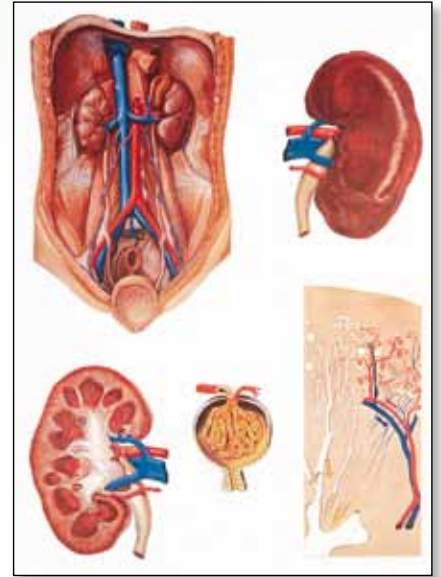

The Kidney
9982-4006523 –
9982-1001165 +

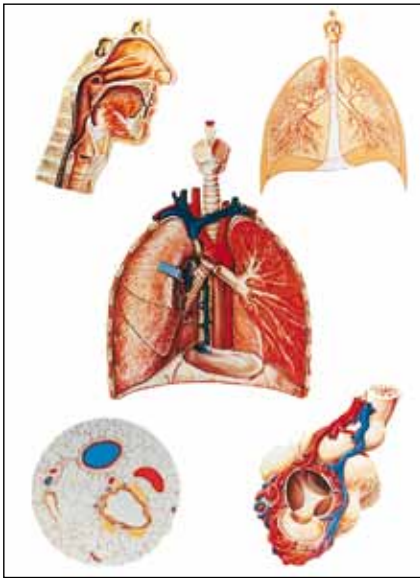

Respiratory Organs
9982-4006538 –
9982-1001188 +

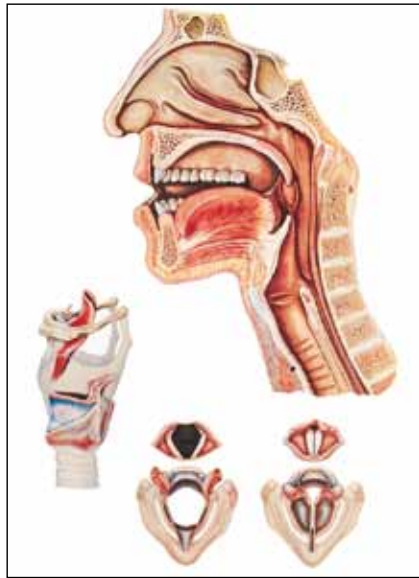

Speech Organs
9982-4006518 –
9982-1001157 +



Healthy Denture
9982-4006524 –
9982-1001167 +

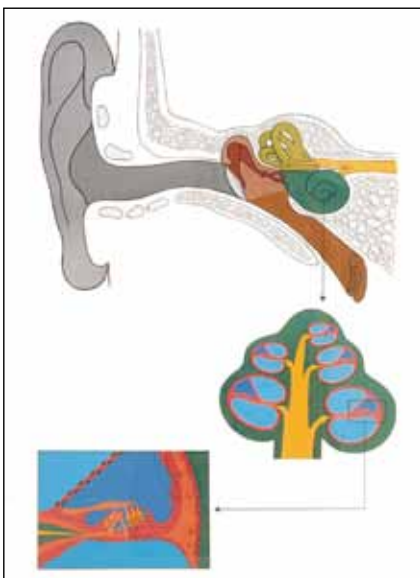

The Ear
9982-4006520 –
9982-1001161 +



The Eye, Anatomy
9982-4006521 –
9982-1001163 +

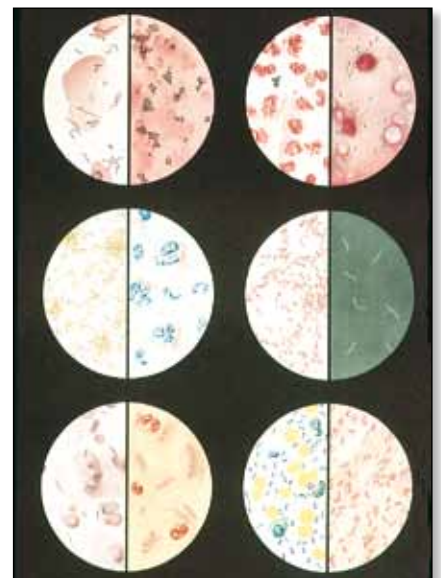

Bacteria
9982-4006541 –
9982-1001194 +

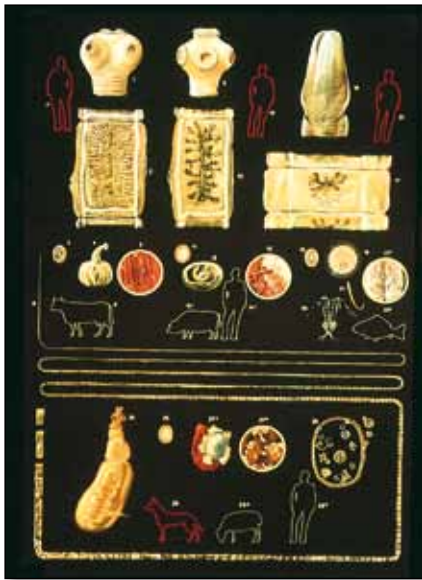

Intestinal Parasites I
9982-4006526 –
9982-1001171 +



Intestinal Parasites II
9982-4006532 –
9982-1001181 +



9982-1005548

Study and Information System for Self Study

Clear layout, inexpensive, effective. Printed on stable cardboard sized DIN A7. Comes in an index-card box.

The Muscular System on Study Cards

- Each muscle illustrated separately
- Identification of origin, insertion, nerve, function, synergists and antagonists
- 303 study cards with 315 illustrations

German

9982-1003740

English

9982-1003741

“Thin Man” – Sequential Human Anatomy Programme

Lets you explore body regions layer by layer by peeling away transparent mylar overlays. Displayed on the rear of the Thin Man is a full-figure view of the skeletal and nervous systems. Over 200 anatomical features are named, indexed, and keyed. The layers display the following systems:

- 1st layer – Musculature of the head, neck, thorax and abdomen
- 2nd layer – Brain, thyroid and salivary glands, eye, tongue, teeth, heart and major vessels, lungs, stomach, liver and intestines
- 3rd layer – Sinuses, nasal, septum, tongue, trachea, heart, chambers, and vessels, pancreas, spleen, large intestine
- 4th layer – Oesophagus, pleura, aorta, inferior vena cava, intercostal vessels and nerves, autonomic nerve trunk, kidneys and adrenal glands
- 5th layer (full figure) – Brain, pharynx, vertebral column, rib cage, muscles of upper and lower extremities, pelvic organs and muscles

160 cm

E

9982-1005548



9982-1003742
9982-1003743

The Skeletal System on Study Cards

- Each bone illustrated separately (360° view)
- Identification of all bone structures
- 303 study cards with 558 illustrations

German

9982-1003742

English

9982-1003743



9982-1003740
9982-1003741

The New LIEDER Program of Interactive CD-ROM

We offer a new range of CD-ROMs for interactive learning and teaching in school and colleges. All pictures and illustrations are taken from our own stocks to provide superior quality. Newly developed programs guarantee easy installation and unproblematic running. Every CD comprises the following topics:

- Comprises a great variety of beautiful diagrams, colour photos, tables, anatomical pictures, electron and X-ray photographs, impressive life cycles, human photographs, landscape photographs, scenes, test data and results, necessary for teaching the subjects.
- Comprises all necessary photomicrographs of microscopic slides, which can be observed by five different steps of magnification by using a "MicroScope". The slides can be moved under this microscope and can be observed in all its parts.
- Comprises all necessary drawings matching the pictures, with explanations of all the parts.
- The same number of comprehensive explanatory texts to help understand the pictures.
- A special test program to check the students' knowledge in several levels of difficulty. A variable number of random selected pictures have to be identified. After a successful run the students receive notes about their progress in learning. By repeating the test any improvement will be revealed by the program.
- A comprehensive index, a search function and a user friendly browser for all pictures and texts on every CD-ROM.
- All pictures can be shown in full-screen size, just by pressing the ENTER button.
- Special accompanying material, which enables evaluation of what has been seen, and creative learning is an important part of the program. Drawings, sketch and worksheets are supplied for many of the pictures on the CD. They are stored in full printing quality (high resolution of 300 to 600 dpi). After printing the drawings may be supplemented or coloured. In addition, the worksheets – which maybe be copied – can be used as accompanying material for class tests.
- The novel demo program features the functionality to start a self-running demo of the program in sequential or random order. A sophisticated presentation mode allows the user to prepare a collection of chosen pictures for an impressive full-screen presentation.
- The complete set of images on this CD can be displayed in thumbnail view for a comprehensive overview of all available material.
- A comprehensive index. The entire set of material, that is, pictures, supplemental texts and slides, and drawings, are accessible via the main program's dropdown-menu Tools – "Search picture..." or "Select picture".
- When starting the CD, English or German can be selected. The program surface is adapted to the well-known "WINDOWS™-LOOK".
- All pictures and texts can be printed by the user.
- The CD works with all Windows versions (WINDOWS™ 95, 98, NT, 2000, XP and VISTA). The resolution is 960x640 or higher for superior quality. Full colour representation with over 1 Million colours (depending on the screen). Optionally the CD runs also on PowerMac G4 and higher with WINDOWS™ emulation.
- The size of the desktop and the windows for texts and pictures can be scaled and adapted to the requirements of the user.

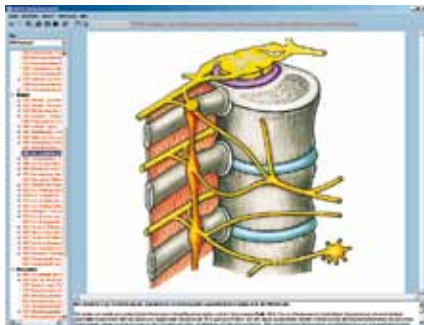

Histology of Man and Mammals

The body of every animal consists of an array of many organs, each of which must perform certain functions within the organism as a whole. The closer study of these organs calls for the preparation of very thin slices of tissue. These slices, when seen through the microscope, show that organs are made of great numbers of wildly differing cells and tissues which, thanks to special staining techniques, can be told apart by the different colours they adopt. Cells, epithelial tissue, support tissue, teeth, muscle tissue, nerve tissue, digestive organs, glands, respiratory organs, blood and blood vessels, lymphatic organs, urinary and excretory organs, sexual organs, spermatogenesis, oogenesis, endocrine glands, scalp and hair, sense organs, central nervous system.

9982-1004273



Division (Mitosis and Meiosis)

A fundamental feature of all living creatures is that their organism grows. The actual growth of multi-cellular organisms results from the increase in the number of cells. Cell divisions make it possible for a single fertilized egg cell to give rise to millions and billions of cells. In the process, chromatin, as carrier of hereditary information, is duplicated, then halved in a highly accurate manner and then transferred to both daughter cells. The complex process of meiosis, the reduction division. Through meiosis not only is the number of chromosomes halved, but also the utterly important rearrangement of chromosome sets and the exchange of segments ("crossing over" process) both take place. The process of cell division is explained through classical examples of known animals and plants. Fine structure of the cell and its nucleus. The sequence of a normal cell division (mitosis) in chronological steps. Resting nucleus, contraction, division and separation of the daughter chromosomes, recombination of hereditary traits and reduction in the number of chromosomes through meiosis, primordial sex cells, entering of a sperm in the egg cell (ovum), prophase, first and second meiosis, dismissal of the sperm's flagellum (tail), mixing of male and female chromosome sets, translation of chromosomes to egg nucleus, mature egg cell with male and female pronuclei, fertilization, cleavage, embryo formation, schematic representation of all phases. The slides, coloured by means of a special staining technique, depict the individual cell structures in contrasting colours.

9982-1004286

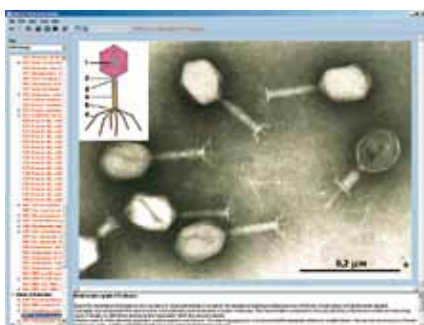

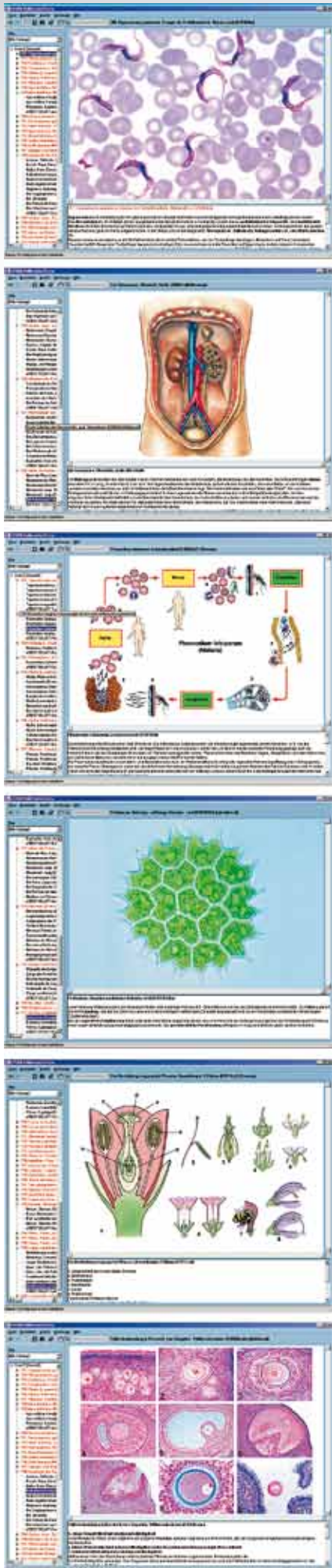

Reproduction and Sex Instruction

Reproduction serves for the preservation of the species. The number of germ cells must balance losses caused by environmental factors (predators, climate, catastrophes), so that the number of reproductive individuals remains constant within certain parameters. The CD provides a vivid introduction into the biology of reproduction from unicellular organisms through to mammals, providing detailed representations of human reproduction and furnishing other teaching material for sexual instruction. Sexual and asexual reproduction. Fertilization of the ovum and fusion of both haploid nuclei. The different types of egg cells and the corresponding types of cleavage. Gastrulation, neurulation, formation of germ layers. Examples of organ development. Structure and function of male and female sexual organs. Testis, epididymis, spermatogenesis, spermatozoa. Structure of the uterus wall. Menstruation cycle and fertilization. Changes in uterine lining (endometrium). Ovulation, admission of the ovum into the fallopian tube, fertilization, development in the fallopian tube and embedding in the endometrium. Growth of the foetus in the uterus. Embryonic and maternal circulation. Foetus in the uterus, placenta, umbilical cord, amnion. Developed foetus in the womb. Start of the birth process, entrance of the amniotic sac into the birthing canal and birth are described.

9982-1004279

Nervous System and Transmission of Information, Part I

Introductory CD for the nervous system. View of the entire human nervous system. Occurrence of the typical nerve cells in the human nervous system. Fine structure of a neuron, composition of the nerve, motor end plates, glial cells, nerve cells and nerve tissue. Neuron, ganglion, centres, reflex arcs, automatism. Embryonic development of the human nervous system. Neural plate, neural groove, formation and closure of the neural tube. Description of the development of different nervous systems of invertebrates and vertebrates facilitates understanding of the human nervous system. Formation of the neopallium from concentric growth rings. Phylogenetic tree of mammalian brain convolutions. Connection between brain sensory and motor nerves and various body areas. Development of the thalamus into a relay station. Progressive concentration and differentiation in the brain, component parts and their relation to each other. Increase in organizational complexity.

9982-1004280

Nervous System and Transmission of Information, Part II

The human central, peripheral and autonomic nervous system. Spinal cord: structure and function. Function of grey and white matter. Diagram of reflex connections. Examination of human reflexes and of diseases affecting the nervous system: polio, syphilis, sclerosis, paraplegia. Embryonic development and hierarchical structure of the brain. Structure and function of brain stem, cerebrum and cerebellum. Course of typical sensory and motor tracts. Perception, conduction and transmission of information. Conscious and unconscious movement controls. The brain is simultaneously connecting and controlling organ: for that reason, information perception, conduction and transmission are treated in a special section: resting potential at the axon sheath and its change. Transmission of information over the synaptic gap. Types of synapse. Stimulus propagation along the axon. The brain's blood supply: as the controlling organ of our body is the brain the biggest consumer of energy. The blood-brain barrier. Brain stem, hindbrain and cerebellum. Brain lesions (diving accident, stroke). The autonomic nervous system, antagonistic effect between the sympathetic and parasympathetic part. Regulation of body temperature. Control of the emptying of the urinary bladder, transmitter and inhibiting substances at synapses and motor end plates.

9982-1004281

Heredity and Genetics of Man, Part I

The basis of both CD's in this series is the range of newest findings in the field of human genetics. As an introduction, the basic knowledge on formal genetics is first imparted, illustrated and explained using many examples from medical genetics. Detailed description of hereditary transmission: Autosomal dominant inheritance, autosomal recessive mode of inheritance, X-chromosomal inheritance, multifactorial and mitochondrial inheritance. Part 2 shows the different types of human tissue cultures, sex chromatin in both normal and pathological numbers of gonosomes through the analysis of Barr bodies, drumsticks and F-bodies. Analysis of metaphase chromosomes by various banding techniques. Chromosomal aberrations and their phenotypic consequences. Secondary chromosomal aberrations following exposure to clastogens and repair defects. Examples from tumour cytogenetics.

9982-1004283

Heredity and Genetics of Man, Part II

Introduction to the principles of molecular genetics. The focus lies on the application of new techniques in medical genetics and in genetic counselling. Furthermore, subject matters such as population genetics, mutations, imprinting, blood group systems and appearance of tumours will be discussed. Subject matters in the last section include principles of genetic counselling and prenatal diagnostics, biopsy of chorionic villi, amniocentesis (foetal blood sampling). Reasons for seeking genetic counselling, effects of damaging to the foetus, risk calculation, consanguinity, genetics of behaviour, and many examples derived from findings in research on twins and the genetic trees of trait bearers. New, extraordinarily high quality images facilitate visual instruction, while detailed accompanying texts place this series at the highest level of modern teaching standards.

9982-1004284

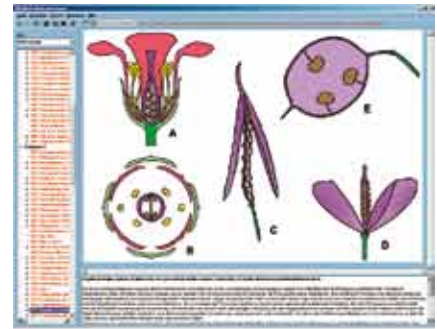

Cytology and Molecular Biology

In cytology and molecular biology, cell nuclei and chromosomes are important structures. Their role in cellular activity, their function and importance in heredity and cell division, as well as aspects of molecular biology will all be discussed. This CD offers a wide range of images and text covering the multiple types of nuclei and chromosomes, including images of mitosis and polyploidy. Typical animal cell and typical plant cell. Living nuclei, nuclear forms and functions. Giant chromosomes. Polyploid nuclei. Fine structure of cell nucleus. Structure of chromosomes. Mitosis. Individuality of chromosomes. Chromosome structure, gene location (loci), reduction division, crossover and chiasmata, gene expansion and arrangement, replication. Proving the material structure of the gene. Structural properties of DNA. Identical replication as a cause of hereditary constancy. DNA, RNA and protein synthesis as causes of character formation. Genetic code and molecular mechanisms in mutations. Didactic guiding concepts: relations between structure and function on the molecular level. Explanation of genetic observations through molecular properties and reactions. The findings illustrated through the hypotheses, methods and experiments that led to those findings.

9982-1004287



Mendelian Laws, Modification and Mutation

In order to establish the fact that heredity is governed by laws, it is necessary to mate living beings that exhibit certain differences from each other. The first experiments in this regard were performed by Augustinian priest Gregor Mendel in the 1860's on the garden of his monastery in Brunn. He crossed different strains of peas and kept track of hereditary transmission of particular characteristics in hundreds of plants over a number of generations. He thus found significant number rules and could thereby gain fundamental insights into the nature of heredity. The term "variability" groups all those alterations in living beings that, on account of not being hereditary, fall within the category of "modifiability". By contrast, alterations that can be passed on through heredity all called mutations. There is no doubt that changes in the hereditary makeup, i.e. mutations, made evolution possible in the first place.

9982-1004290

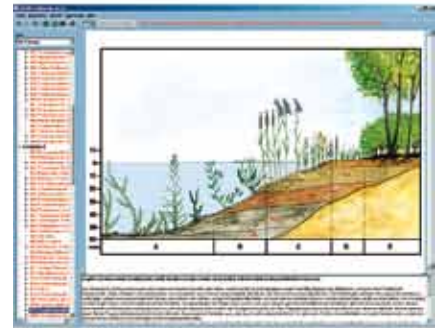

The Wonder of the Animal Cell

The cell is the basic element of all living organisms. In unicellular organisms, a single cell performs all those vital processes for which multicellular organisms have developed specialized cells: muscle cells can contract, glandular cells secrete substances, sensory cells perceive stimuli and transform them into impulses, nerve cells conduct impulses, connective tissue cells produce an intercellular substance, red blood cells transport oxygen, white blood cells fight pathogens, sex cells insure reproduction and propagation of species. The multiplication of cells results from their division. To increase their effectiveness, cells form tissues. Different tissues work together to perform certain tasks and thereby form an organ. This CD introduces in a graphically clear manner into the variety of cells and tissues occurring in the animal and human body.

9982-1004289

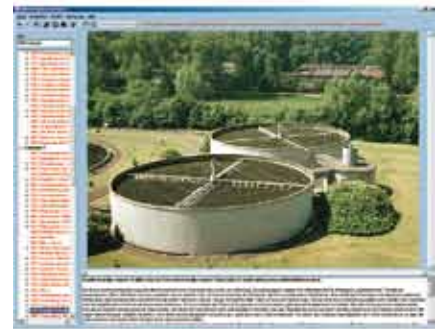

The World of Insects

With over 1 million species, arthropods are by far the largest animal group on this planet. They include insects, spiders, millipedes and crustaceans. They share such characteristics as segmented legs and a hard external skeleton made of chitin, which encloses the entire body like an armour and serves both as protection and support. Many microscope enthusiasts started their hobby observing small insects and insect parts. That is easy to understand, considering that insects are ubiquitous and easy to catch. This CD reveals the enormous variety of insects and their fine structures using selected examples.

9982-1004291

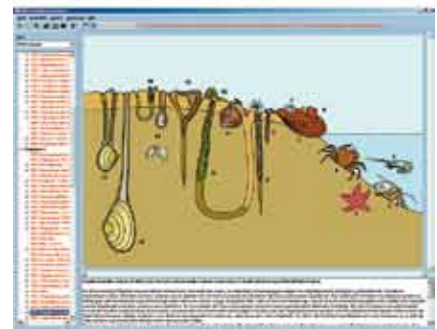

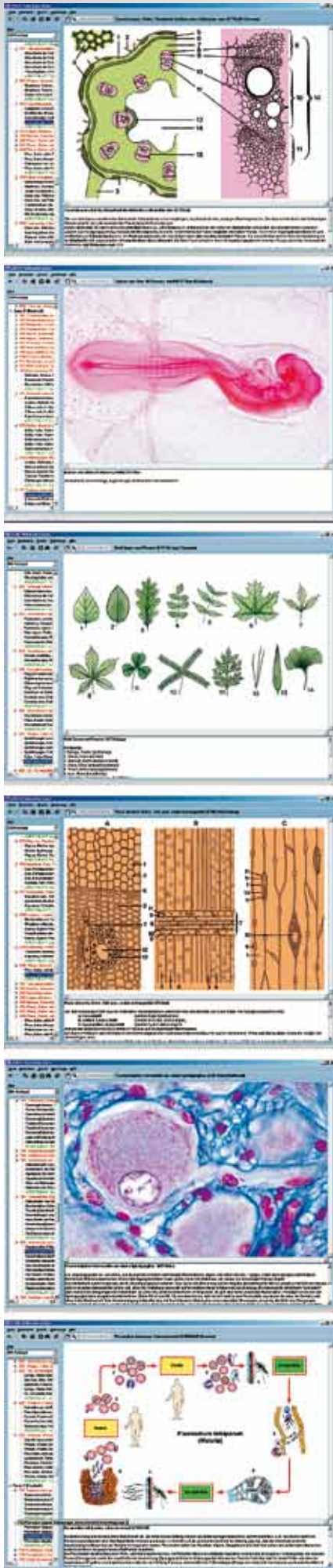

Zoology in the Classroom

Morphology, the study of the structure of organisms and of the relationship among their constituent organs, together with taxonomy, the science dealing with the relationships among organisms and their classification into a hierarchical system, are closely associated. Without morphology and taxonomy, biology could not be conducted in a meaningful way. When taught separately, both are tedious subjects for nearly every student. But if the teacher puts structure, function and relationship into a meaningful context, analyzes these factors and shows how a taxonomic unit propagates throughout the available habitats, i.e. when radiation takes place, and when it finally becomes evident that a certain "blueprint" has been "invented", these otherwise dry subjects gain life and become interesting. This CD offers some interesting insights into some problems regarding structure and function within the context of animal taxonomy. The CD contains a wealth of colour photographs, illustrations and detailed diagrams of basic body structures of the animal classes, as well as micro and macrophotographs that may be enlarged to full-screen size or printed at the touch of a button.

9982-1004292

The Wonder of the Plant Cell

Few things in living nature are so multifaceted as the forms that plant cells can adopt. Depending on their function, they can be symmetrical and smooth-walled filling cells, repeatedly-branched trichomes, star-shaped, ring-shaped, corkscrew-shaped or reticular vessel cells, shut-off cells, storage cells with substances including crystals, woody cells, pollen cells with superficial features characteristic to each plant, etc. Even the leafless plants stand out for their multiplicity of forms: unicellular and multicellular green algae, blue algae, golden algae, fire algae, and particularly the diatomea, with their wildly varying shell forms possessing a remarkable aesthetic appeal.

9982-1004293

Botany in the Classroom

The purpose of this CD is the same as that of CD 9982-1004292, but focused on botany. Plant derived foodstuffs form the basis of human nourishment. Given that modern students enjoy ever diminishing opportunities to observe or take part in sowing, cultivating, harvesting and utilization of crops, this CD attempts to fill that void. The most important crops are listed, noting their flowering periods in Roman numerals. Pictures of plants and data on their provenance, history, cultivation and utilization provide the teacher a wealth of material for a varied and interesting botany lesson.

9982-1004294

Biology of Flowers and Fruits

One of the identifying features of higher plants is the occurrence of flowers and fruits, whose complex structure under the microscope makes for interesting observations. Some plants, such as conifers, build male and female germinal elements in different flowers. The formation of seeds and fruits is determined by the different modes of dispersal, such as by means of edible fruit flesh or of dehydration-resistant grains. Flower biology or ecology examine and describe the interactions occurring in the pollination process between flowers and their non-living and living environment. Among the external forces that make pollen dispersal possible are wind, water and transportation by animals. Of these three, pollination through animals ranks as the uppermost method, being the most effective and common of all.

9982-1004295

Crop Pests and Controls

Since man started to practice agriculture, he had to "defend" his crops against damaging organisms. Often, a large part, if not all, of a harvest is lost to harmful plants or pests, mostly caused by different types of fungi. For their multiplication and propagation, these fungi produce colossal amounts of extremely resistant spores. Exact knowledge of the way of life of these harmful plants is necessary to combat them effectively. The pictures, showing crops affected by pests, will be of interest to hobby gardeners and farmers alike. The CD deals also with a very promising aspect of global environmental protection: biologic pest control. Using well known, easy to follow examples, the subject is explained and its goal made more accessible.

9982-1004296

Our Environment, Threats and Protection

The relentless advance of technology in nearly all areas of life, together with consequences that more often than not exert an influence on our natural make-up, represent a steadily increasing threat to the environment. Comprehensive environmental protection is therefore urgently needed. The new school curricula reflect this need, by including chapters on "Environment, Environmental Threats, Environmental Protection". This CD attempts to provide a vivid support to such classroom work. Based on representative examples in the areas of Landscape, Soil, Water and Air, it shows which activities threaten the make-up of our natural environment and how the resulting perils can be confronted.

9982-1004285

Biotopes and Ecosystems

Habitats left in their natural state are becoming increasingly rare. Using selected examples, these habitats' wealth of species, the problems of preserving them and the importance for the overall ecological framework even of small biotopes are documented and discussed. This CD aims at presenting the animal and plant populations of these habitats using typical examples, dealing with their adaptations and their place in the ecosystem. Nearly all photographs were taken in situ, in order to preserve authenticity. The accompanying texts provide detailed explanations on the biology of each species and the emergence and ecology of each habitat. Animal and plant population of a fishpond and a puddle, tarn, moor, timber forest, mountain meadows, shallow coastal waters.

9982-1004288

Life in Water

The fascinating underwater world first reveals its diversity when seen under the microscope. The photographs of this CD unveil the multitude of interesting living organisms that can be found in a single drop of water taken from a pond. It is like a window into a new, wonderful world: the fascinating, improbably rich realm of the smallest living beings. The astonishment caused by things invisible to the naked eye and the joy of watching these tiny creations of Nature provide the basis and stimulus for a lively schoolroom teaching experience. Simultaneously, these small creatures constitute the first link in a feeding chain which leads through small crustaceans and ever larger water animals to humans. The interaction between the tiniest organisms and fishes is sensitive even to small habitat alterations, such as changes in water temperature or in oxygen content.

9982-1004289

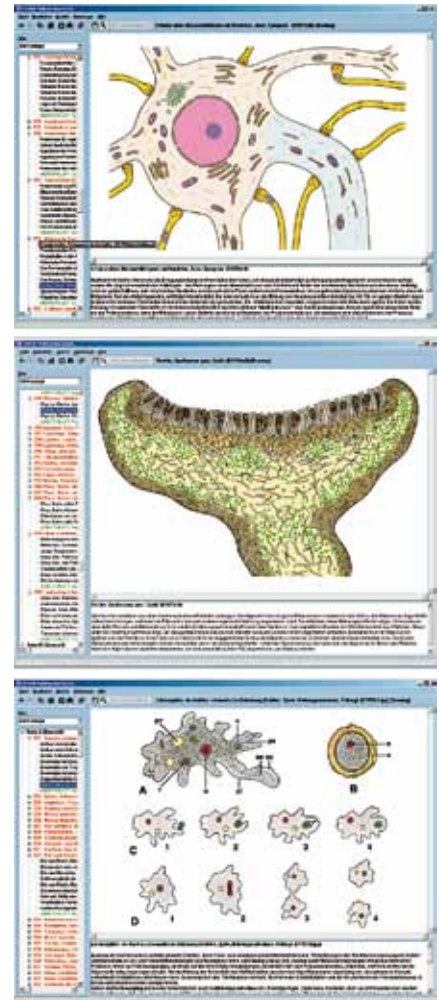

Further interactive CD-ROMs for teaching in school and education

9982-1004298	Our Waters, Pollution, Protection and Recycling
9982-1004299	The Origin of Life and Evolution
9982-1004300	Embryology and Development
9982-1004301	Evolution in Examples
9982-1004302	Anatomy of Phanerogams
9982-1004303	Anatomy of Cryptogams
9982-1004304	Human Parasites and Diseases
9982-1004305	The Forest as a Habitat
9982-1004306	The World of Butterflies
9982-1004307	Edible and Poisonous Mushrooms
9982-1004308	Healing and Poisonous Plants
9982-1004309	Art Forms in Nature – The Realm of the Infinitesimal
9982-1004310	The Structure of Matter, Part I: Fundamentals
9982-1004311	The Structure of Matter, Part II: Petrography and Mineralogy

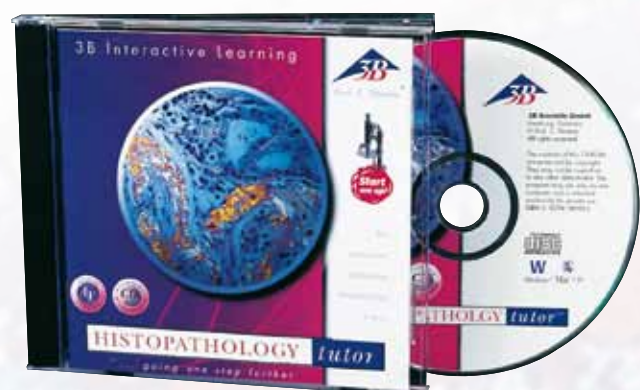

9985-1004881
ISBN 978-3-8294-0001-5

CD-ROM Histopathology, English (Macintosh/Windows)

This presentation of a histopathology course unites the view of microscopic illustrations with spoken explanations in a handy manner. The program accompanies medical students through the entire course of histopathology but it also allows the experienced practitioner to revise basic knowledge.

9982-1004881

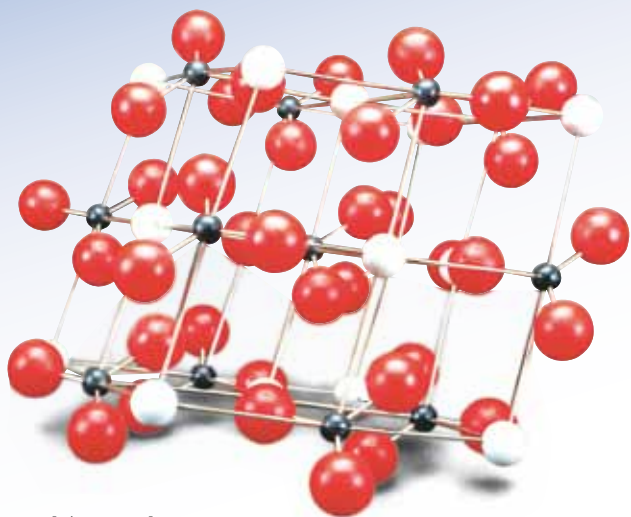

Calcium Carbonate

9982-1002530



Carbon-Carbon Bond

9982-1002526

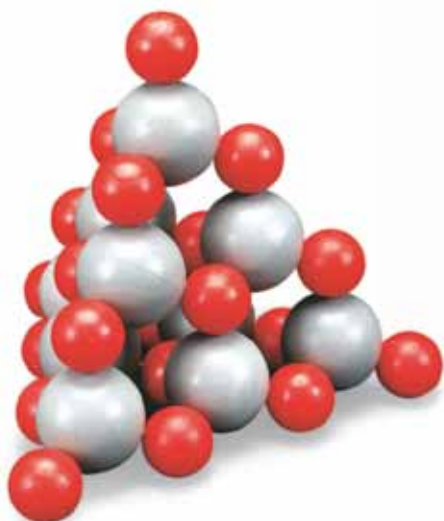

Silicon Dioxide

9982-1002528



Graphite

9982-1002522

Further Information at:
www.3bscientific.com



Sodium Chloride

9982-1002521

More Product Ranges

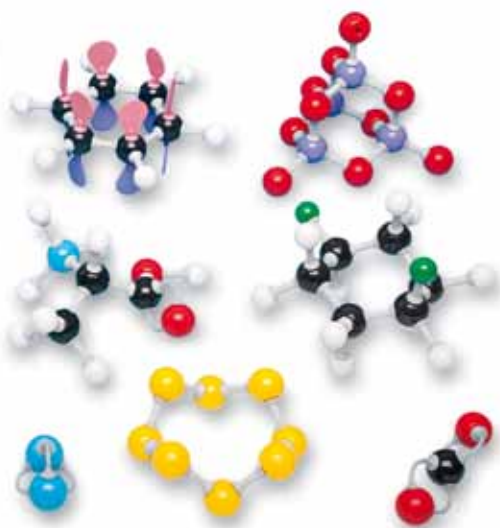

Inorganic/Organic (Teacher) Set – Open Models only

9982-1005279

Introductory Molecular Construction Set

9982-1005051

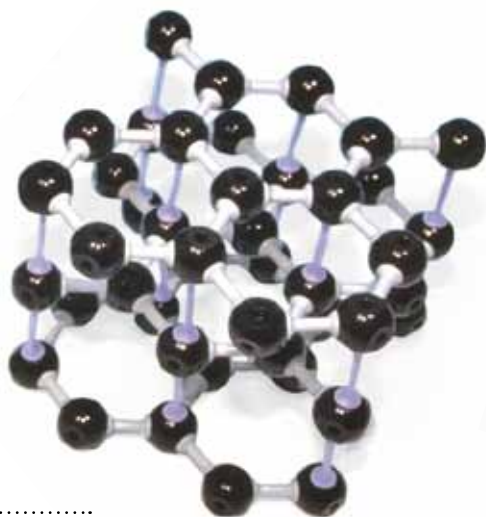

Graphite Kit 3 Layers

9982-1005283



Diamond Kit

9982-1005282



Class-Set – Inorganic/Organic Chemistry

9982-1005306



Student-Set – Inorganic/Organic Chemistry

9982-1005291



Orbit™ Colour Wave™ – Carbon 60 – Fullerene

9982-1005311

Orbit™ Colour Wave™ – Iron

9982-1005314

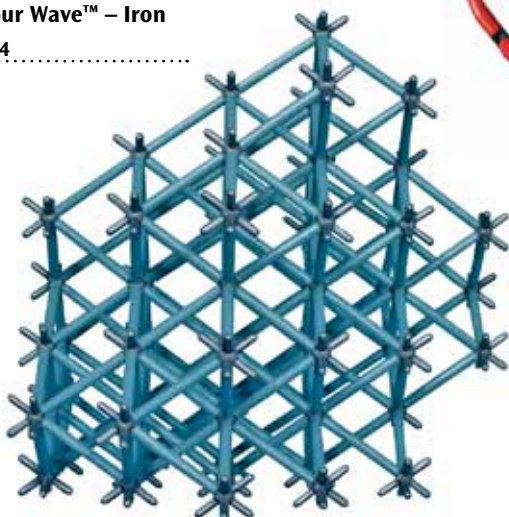

Orbit™ Colour Wave™ – Copper

9982-1005316

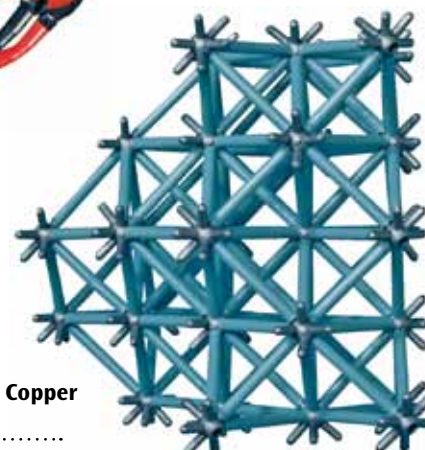



Mechanics Kit for Whiteboard
9982-1000735

Free-Fall Apparatus
9982-1000738



Laminar Flow Apparatus
9982-1006784

Further Information at:
www.3bscientific.com

BEST SELLER

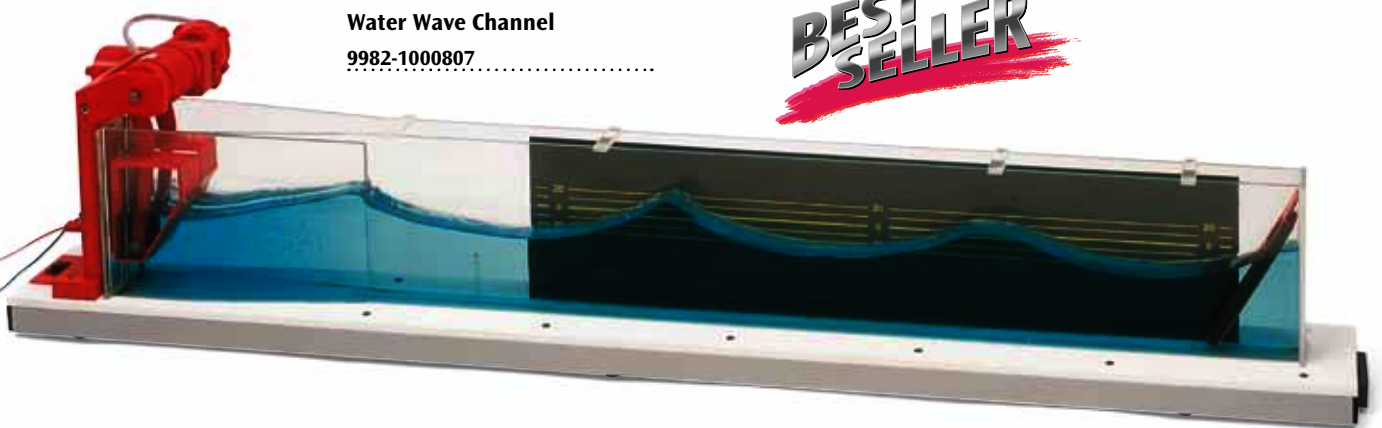

Water Wave Channel
9982-1000807

Franck-Hertz Experiment

**Power Supply Unit for Franck-Hertz Experiment
(230 V, 50/60 Hz)**

9982-1012819

**Power Supply Unit for Franck-Hertz Experiment
(115 V, 50/60 Hz)**

9982-1012818

Franck-Hertz experiment
with mercury



BEST SELLER



Fine Beam Tube T

9982-1008505

Operating Unit for Fine Beam Tube

9982-1008520

**Further Information at:
www.3bscientific.com**

NEW



Electron Deflection Tube D

9982-1000651



Equipment Set for Wave Optics with Laser

9982-1003053



More Product Ranges

...going one step further



Moonhopper®
 Equilibrium for children.

9982-1003720

Moonhopper® for adults
 With an extremely stable disc.

9982-1003733



BEST SELLER

Redondo® Ball

Art. No.	Colour	Weight / Diameter
9982-1003695	Blue	0.14 kg / Ø 22 cm
9982-1003696	Red	0.16 kg / Ø 26 cm

Further Information at:
www.3bscientific.com

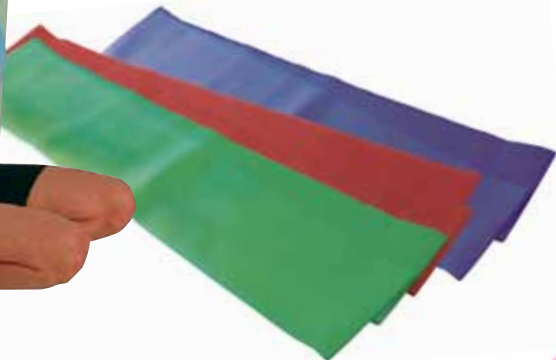

Powerband, 5 m

Art. No.	Colour	Widths/Resistance
9982-1003716	Green	15 cm, light
9982-1003718	Violet	15 cm, heavy
9982-1003719	Red	15 cm, extra heavy

ABS® Power Gym Ball

Art. No.	Colour	Diameter
9982-1003697	Red	45 cm
9982-1003698	Green	45 cm
9982-1003700	Blue	45 cm
9982-1003701	Silver	45 cm



45 cm – 75 cm



More Product Ranges

Product	Page	Product	Page	Product	Page
A		Cow Skull	54	Glucose, molecule model	145
Additive Colour Mixture	129	Cow Foot	54	Goose skeleton	52
Adrenal Gland, Kidneys with	44	Cytology, Micropreparations	93-94	Gorilla skull	55
Aeroplethysmograph	127				
Agar	139	D		H	
Agarose	135	Dandylicon	57	Hair hygrometer	119
AIDS Virus (HIV)	149	Daylight Projector	116	Hand skeleton	14
Alimentary Canal	43	Dental Hygiene Model Large	33	Hand structure model	14
Amino Acid Set, Molecule Model	145	Dentures	32-33	Hare skeleton	53
Amphibian	50	Dicotyledonous Plants	56-59	Hare skull	53
Anatomical Model, Human	10-47	Diffusion	138	Head model	32
Anemometer	119	Digital Water Bath	113	Heart model	41-42
Aneroid Barometer	119	Dip Net	126	High blood pressure model	42
Animal Cell	60	Disc Plastinate	48	Hip joint	23-24
Anthropological Skull	47	Disc Torso	31	Histology, micropreparations	87-88
Antibiotics Test Ring	139	Disecting Set	108	Histopathology, CD-ROM, English	171
Apple Blossom	59	Dissecting Instruments	111	Honey bee	49
Arm, Muscle	26	Dna Experiments	134-136, 138	Horse foot	54
Arteriosclerosis Model	42	Dna Ladder, 100 bP	135	Horse skeleton	55
Artery and Vein	42	Dna Models	142-143	Horse skull	55
Atom Model According to Bohr	141	Dog Leg	54	Human cell	61
Auditory Ossicles	38	Dog Skeleton	54		
		Dog Skull	54	I	
B		Double Helix	142-143	Individual micropreparations	96-97
Bacteriological Starter Kit	139	Drigalski Spatula	139	Inoculation loop	139
Barometer	119	Drugs Education	150-151	Insects	48-49
Basic Billy	147	Duck Skeleton	52	Instruction chart stand	160
Basic Life Support Simulator	147	Duodenum, Liver with	43	Instruction chart stand	160
BeakerGlasses	110			Instruction chart, anatomical and	
Biochemistry	144-146	E		pathological	154-160
Bird	52	Ear Model	38	Interactive CD-Roms	166-171
Birthing Phase Model	46	Eco Test Water Laboratory	125	Interface 3B NETlog™	121
Blood Circulation – Functional Model	53	ECOLABBOX	124	Inversion goggles	131
Blood Group Diagnosis	128	Ecology And Environmental Protection,		IUP training model	148
Blood Pressure Box	122	Micropreparations	94-95		
Blood Pressure Meter	127	Ekg/Emg Box	122	J	
Blood Test	128	Elbow Joint	23-24	Joints	23-24
Bone Structure Model, 3B MICROanatomy™	13	Electrophoresis Chamber	114		
BONElike™	17, 21	Electrophoresis Station	114	K	
Botanics, Micropreparations	91-93	ELISA-HIV/-Aids-Test	128	Kidney model	44
Brain Model	33-34	Embryo Model	45	Knee joint	23-24
Bronchial Tree – Model	40	Embryology, Micropreparations	93-94		
Butterfly	48	Endocrine System	152	L	
		Enzyme	133	Laboratory coat	112
C		Eppendorf Tips	111	Laboratory equipment	113-116
Cameras	78-80	Experiments	123-140	Laboratory material	110-112
Camomile	57	Extracting DNA from an Onion	138	Laboratory scales	114
Castor-Bean Tick	48	Eye Model	36-37	Larynx model	40-41
Cat Skeleton	54	Eye, 3B MICROanatomy™	37	Laser array box	130
Cat Skull	54			Laser pointer	160
CD-ROM	86, 166-171	F		Leaf structure block model	60
Cell Biology	60-62	Family Planning, Training Model	148	Learning cards	165
Cell Division	62	Fat Molecule Model	145	Leg, muscle	26
Cell Structure of a Leaf, Relief Model	60	Foetus Model	45	Liver model	43
Cellular Biology Model	60-62	Foetus Skull	16	Liver, 3B MICROanatomy™	43
Centrifuge, Small	113	Fire Salamander	51	Lizard	51
Cervical Vertebrae, BONElike™	21	First Aid	147	Lumbar vertebrae model	20
Chemical Principles	141-146	Fish Skeleton	49	Lung model	40-41
Cherry Blossom with Fruit	59	Flavour Enhancer, Experiment	140	Luxmeter	118
Chicken Skeleton	52	Foot Skeleton	14		
Chimpanzee Skull	55	Frogs	50	M	
Circulation	42	Functional Model	19, 24, 37, 38	Magnetic stirrer	113
Common Oak	59			Magnifying glasses	83
Companion Book to the School Series	85	G		Mammal tooth forms	53
Comparison of the Spinal Cord	19	Gall Bladder, Liver with	43	Mammalian foot form	53
Computer Assisted Measuring		Gastec Gas Detector	123	Mammals	53-55
Apparatus	120-122	Gel Electrophoresis	114	Meadow sage	57
Condom Practice Model	148	Gel Loading Buffer	135	Measuring apparatus	118-122
Contraception	148-149	Genetic Finger Print	135	Measuring cylinder	110
Contraception Case	149	Genetics	62, 134-135, 137-138	Measuring pipettes	111
Correct Lifting, Demonstration Figure	20	Glass Cell	61	Medical poster	154-165
Cover Glasses	109	Glass Slide	109	Medulla model	35
Cow Skeleton	54	Gloves, Vinyl	112	Meisos model	62

Product	Page	Product	Page	Product	Page
Menstrual Cycle	152	Pig Skeleton	55	Staining Box, Schiefferdecker Type	109
Methylene Blue Colour Concentrate	135	Pig Skull	54	Stan, Classic Skeleton	10
Micro Pipettes	111	Pilewort	58	Stereo Microscope	74-77
Microanatomy™-Model	13, 26, 37, 42, 43	Pipette man	111	Stethoscope	127
Microbiology	139	Plankton Net	126	Stimulus Conduction in Nerve Fibres	132
Microcentrifuge Piccola	113	Plant Cell	60	Stomach Model	43
Microlitre Pipette	111	Plant Physiology	133	Stop Watch	118
Micropreparations	84-97	Plant Stems, Cross-Section	60	Storage Box for Object Slide	109
Microscope	63-77	Plastinate	48	Structure and Function of DNA	142-143
Microscope Accessories	81-82	Pointer For Instruction Chart	154	Sunflower	56
Microscope Digital Cameras	80	Polymerase Chain Reaction	136		
Microscopy	63-83	Poster, Anatomical and Pathological	154-165	T	
Microscopy Shears	110	Potato Flower	59	Tae Puffer	135
Mini Joints	24	Power Supply for Electrophoresis	114	Teeth, Human	32-33
Mini Skeletons	13	Pregnancy Pelvis	45	Telescope Bars	126
Mini Spines	19	Pregnancy Series	45	Test Sets	125
Mini Torso	31	Preparations Portfolio	109	Test Tubes	111
Minidna™ Molecular Models	142	Pressure Adjustment in the Middle Ear	38	The Organ of Corti	38
Mitochondrium Dna Analysis	136	Primrose	58	Thermocycler	113
Mitosis Model	62	Probe	110	Thermometer	117
Molecule Model	142-146	Protective Gloves	112	Thin-Layer Chromatography	140
Monocot Plants	56	Protective Goggles	112	Tick	48
Morphology	56-60	Pulse Meter	127	Timer	118
Mortar and Pestle	111			Tissue Structure of the Crowfoot Root	60
Motoneuron Diorama	35	R		Tissue Structure of the sunflower Stem	60
Mouse Skeleton	53	Rain Gauge	119	Toad Rush	50
Multi-Media Package	98-107	Rape	58	Tooth Disease	33
Muscle Arm	26	Rat Brain	34	Torso Film Set	27
Muscle Fibre, 3B Microanatomy™	26	Rat Skeleton	53	Torso Guide	27
Muscle Figures	25-26	Rat Skull	53	Torso Model	27-31
Muscle Leg	26	Relief Model	152-153	Tulip	56
		Replication Stamp	139	Tweezers	110
N		Reproduction and Development	45-46		
Nephron	44	Reptiles	51	U	
Nerve Cell	35	Resuscitation Simulator	147	Urinary Tract Model	44
Nervous System	35	Rhesus Factor	128		
Nervous System Physiology	35, 132	Rna Model	143	V	
Net/ab™	120	Rock Micro-Sections	95	Vaginal Condom Practice Model	148
Net/log™	121	Rodents	53	Venous Valves in Function	42
Newton's Colour Wheel	129	Root Absorption Zone, Relief Model	60	Vertebrate	50-55
Nose Models	40				
		S		W	
O		Sacrum With Coccyx	20	Wall Charts	160-165
Oil Test Paper	125	Sampler	126	Wash Bottle	111
Ontogeny	46	Scales	115-116	Water Anomaly	124
Orangutan Skull	55	Scalpel Blade	110	Water Dip Net	126
Organic Chemistry	144	Scalpel Handle	110	Water Investigation	124
Osmosis	138	Schiefferdecker Staining Box	109	Water Sampling Beaker	126
Outdoor Investigations	124-126	School Series, Micropreparations	84-85	Water, Experiments	124-125
Overhead Projector	116	Sense Organs	35-39	Weather	119
Oxygen Test Set	125	Sensors Net/ab™	122	Weather Station, Cordless	119
		Sensory Physiology	129-131	Wheat Blossom	56
P		Sensory Physiology Equipment Set	131	Wild Rape	58
Pancreas, Liver with	43	Sex Education	148-149	Wings And Feathers of a Pigeon	52
Parasitology and Pathogens, micropreparations	90-91	Shears	110	Wire Screen Dip Net	126
Pasteur Pipettes	109	Sheep's Skeleton	55		
PCR	113, 136	Sheep's Skull	55	Z	
PCR Experiment	136	Shoulder Model	23-24	Zoology, Micropreparations	89-90
Pcr Machine	113	Sickle Cell Anaemia	134		
Pea	58	Skeleton Dust Cover	11		
Pelvis – Central Cross Section	22	Skeleton, Animal	49, 52-55		
Pelvis Skeleton	22	Skeleton, Human	10-13		
Petri Dishes	111	Skin Cancer Model	39		
Ph Indicator Diagnostic Dipstick	125	Skin Model	39		
Ph Indicator Paper	125	Skull, Human	15-17, 47		
Pheasant Skeleton	52	Skull, Mammal	53-55		
Phosphatase	133	Slipped Disc	20		
Photosynthesis	133	Snakes	51		
Photosynthesis, Equipment Set	133	Software	166-171		
Phylogenetics	47	Sound-Level Meter	118		
Pigeon Skeleton	52	Spinal Cord, Human	18-21		
Pig Foot	54	Spinal Model, Human	20-21		
		Spinal Stand	18		



3B Scientific History



The international 3B Scientific group of companies is the world's largest and most experienced manufacturer of anatomical teaching aids. The oldest production site was set up as early as 1819 in Budapest, Hungary. The continuously growing success of 3B Scientific is the result of global expansion, based on the production and sales of high-quality medical and scientific teaching aids available at fair prices. The internationally registered brand name 3B Scientific® can be found around the world in the fields of natural sciences, medical training and patient education. The product range includes products for lectures in physics and biology as well as anatomical models, software and charts, medical simulators, acupuncture and other therapy products. The company has been awarded the DIN EN ISO 9001:2008 certification for the excellent quality of its services, products and organizational structures. This official step towards quality management emphasizes the continuing process of innovation, product improvement and customer orientation that is associated with the brand name 3B Scientific®.

3B stands for: *Best Quality Best Value Best Service*



- 1819 Calderoni founded in Budapest, Hungary
- 1912 Training Workshops of the German Hygiene Museum founded in Dresden
- 1948 Paul Binhold Lehrmittelfabrik founded in Hamburg
- 1950 Production of the first plastic skeleton
- 1952 First skeleton manufacturing plant opened
- 1963 New headquarters at Rudorffweg, Hamburg
- 1965 Introduction of the Torso product line
- 1970 Introduction of the Binhold company logo
- 1979 Anatomical models first exported to the USA
- 1983 First manufacturing of injection moulded skeleton parts
- 1986 Care simulators added to the product range
- 1988 Anatomical models first exported to Japan
- 1991 DHM Lehrmittelfabrik GmbH founded in Dresden
- 1993 Acquisition of Calderoni and foundation of Biocalderoni in Hungary
- 1995 American 3B Scientific founded in Atlanta, USA
- 1996 New logo for the 3B Scientific Group
- 1997 Nihon 3B Scientific founded in Niigata, Japan
- 1998 France 3B Scientific founded in Bartenheim, France
- 1998 Merger of Paul Binhold Lehrmittelfabrik GmbH and DHM Lehrmittelfabrik to form 3B Scientific GmbH
- 1999 China 3B Scientific founded in Suzhou, China
- 2000 DIN EN ISO 9001 certification
- 2001 Introduction of the full 3B Scientific® product range for physics
- 2002 Italy 3B Scientific founded in Bologna, Italy
- 2003 España 3B Scientific founded in Valencia, Spain
- 2003 UK 3B Scientific founded in Weston-super-Mare, United Kingdom
- 2004 All-European distributor of SEIRIN® acupuncture needles
- 2004 Acquisition of ELWE Didactic GmbH in Klingenthal
- 2005 Acquisition of TELTRON® brand name and production
- 2005 Russia 3B Scientific founded in St. Petersburg.
- 2006 Brasil 3B Scientific founded in Joinville, Brasil.
- 2007 Thai 3B Scientific Co Ltd., founded in Bangkok, Thailand
- 2009 DIN EN ISO 9001:2008 certification
- 2011 Implementation of SAP as business controlling software

...going one step further



Page 16



Page 142



Page 31



Page 33



Page 46



Page 10



Page 58



Page 147



Page 60

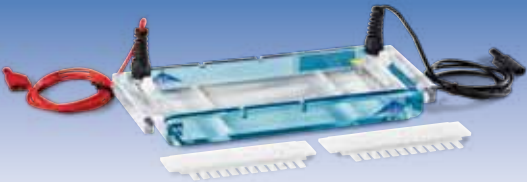

Page 114



EuroDidact®