

## 5.3 Student's Section

In this investigation you will examine the influence the angle of incidence of the light source has on the electrical power coming from the solar panel.

### 5.3.1.1 How Can We Maximize the Electrical Power Coming from the Solar Panel?

- Wear goggles when experimenting.
- ✓ Solar panel
- ✓ Load measurement box
- ✓ Two patch cords, red and black
- ✓ 100–120 watts PAR lamp, or equivalent light source
- ✓ Measuring tape
- ✓ Protractor to measure angles (or make your own paper protractor from the template on page 45)

Safety



#### CAUTION

##### Hot surface of solar panel and lamp!

Skin burns.

- Do not touch the hot surface of the solar panel or lamp.
- Allow solar panel / lamp to cool down before touching it.



#### CAUTION

##### Ignition of hydrogen!

Skin burns and damage to the fuel cell.

- No open flames.
- No smoking.
- Well ventilated workspace.

1. With the patch cords connect the solar panel to the load measurement box CURRENT terminals – red to red and black to black.



**NOTICE**

**Overheating of the solar panel!**

Malfunctioning of or permanent damage to the solar cells.

- ➔ Only use light sources with a maximum power of 120 W.
- ➔ Keep a minimum distance of 20 cm (8 inches) between light source and solar panel.
- ➔ Do not concentrate light.

2. Position the light source.

3. Turn the selectable *LOAD* knob to *SHORT CIRCUIT*.

Press the *ON / OFF* button.

4. Check if a number appears in the "A" window. If nothing appears, check your connections. If a negative number appears, you have the connections reversed and have to change them.

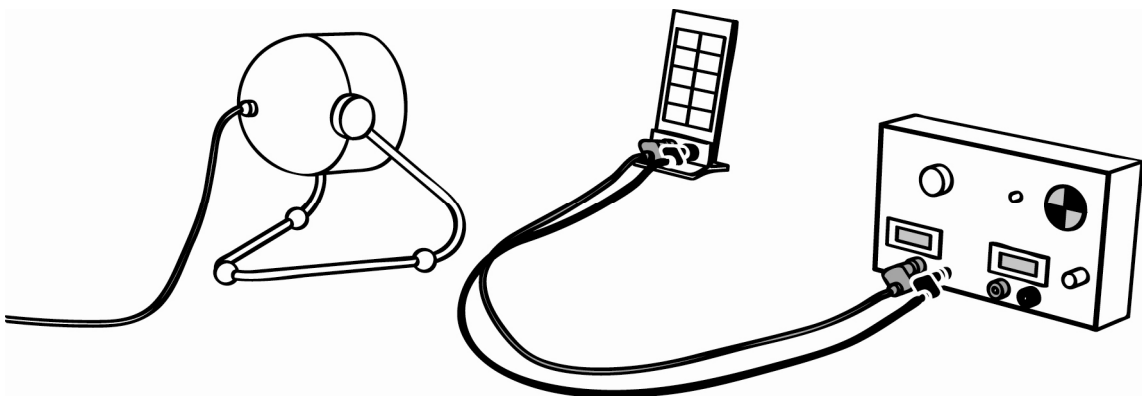

Fig. 5-7 Set up solar panel and load measurement box

5. Adjust solar panel and light source so they are about 40 cm apart and the angle of incidence is exactly at 0 degrees. That is, the panel faces directly toward the light source.

6. Turn on the light.

7. Move the light towards or away from the solar panel, keeping the angle of incidence at 0 degrees, until the current shown in the "A" window is between .100 and .150 amperes. To prevent the solar panel from getting too hot, do not bring the light closer than 20 cm (8 inches).

**Get results!**

8. Measure this distance and write it down.
9. Write the current displayed in the ammeter into the table below.

	<p><b>TIP</b></p> <p>Notice that the displayed number has a leading decimal point. For example the number .105 A represents a little more than a tenth of an ampere, or 105 milliamperes.</p>
---	---

Angle of incidence [degrees]	Predicted current [mA]	Actual current [mA]
0°		
10°		
20°		
30°		
40°		
50°		
60°		
70°		
80°		
90°		

Table 5-4 Angle of incidence

10. Place the solar panel so the angle of incidence is exactly 90 degrees from the light source, taking care to keep the center of the solar panel exactly the same as before.
  11. Write down the current displayed in the ammeter window.
- From the results so far, you may predict what the current is at an angle of 10 degrees:
12. What do you think the current will be at a 10-degree angle of incidence. Write down your prediction in *TABLE 5-4 ANGLE OF INCIDENCE*.
  13. Using your protractor template (see *FIG. 5-10* on page 45), adjust the angle of incidence of the solar panel to 10 degrees still keeping the center of the solar panel exactly the same as before.
  14. Record the actual current in *TABLE 5-4 ANGLE OF INCIDENCE*.

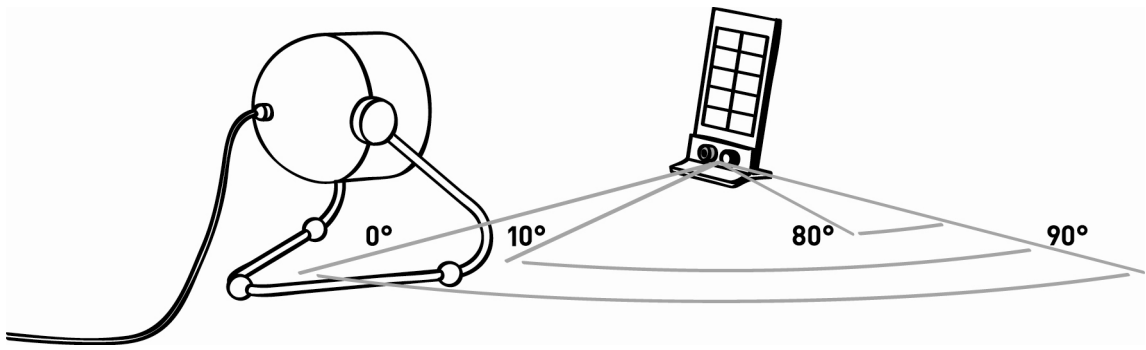

Fig. 5-8 Setting the solar panel

15. Continue predicting and measuring in this way at 10 degree intervals until you reach 80 degrees. Check the distance to the center of your solar panel for each measurement.
16. When you have made and recorded your measurements, use your data to draw a graph indicating your findings in the space below.  
Your experimental part is finished – in order to gain more information, you have to process your data further:
17. Using the data from *TABLE 5-4 ANGLE OF INCIDENCE*, fill in your findings into the graph provided below.

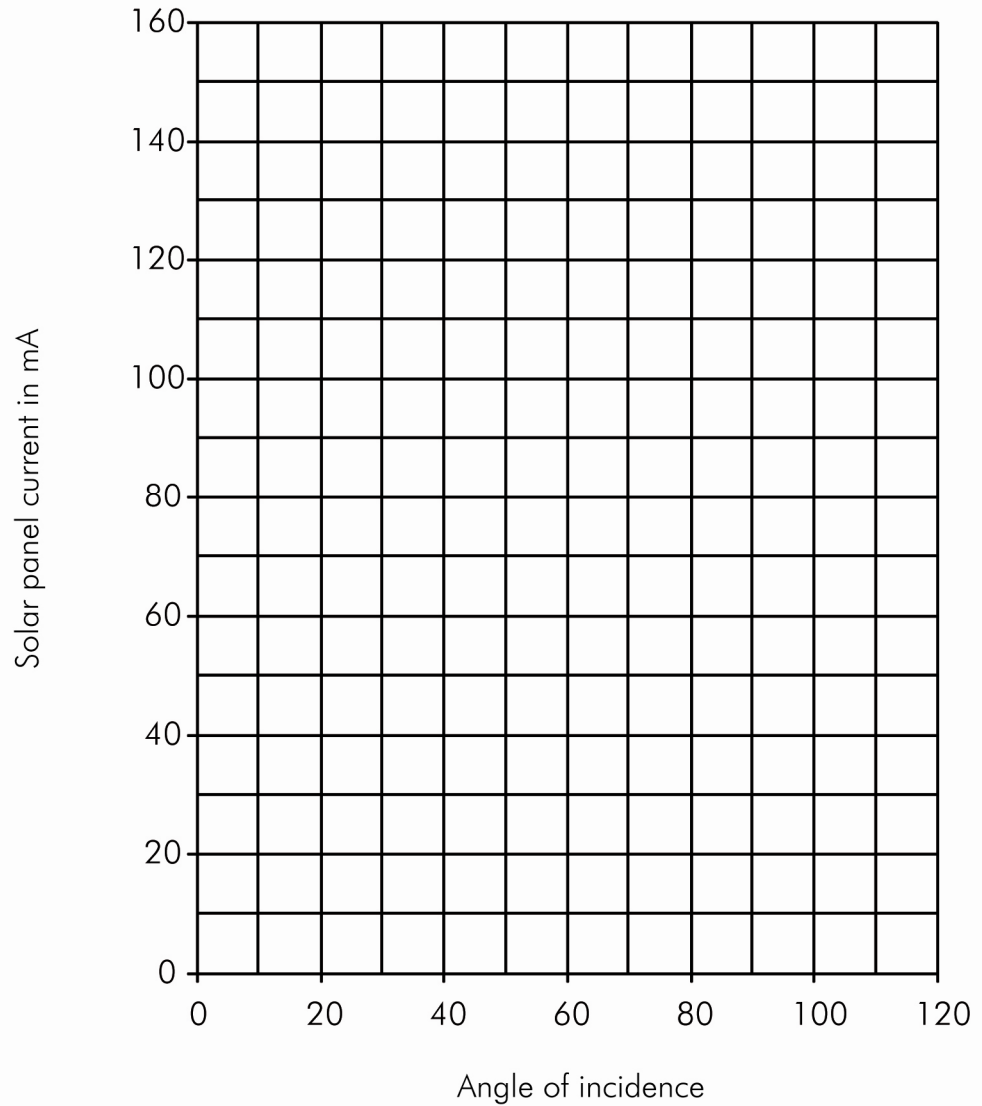

Fig. 5-9 Current as a function of the angle of incidence

Now your investigations and data gathering are finished. You can now go on interpreting your findings and checking your knowledge.

But before doing so:

- ➔ Turn off the light source.
- ➔ Let the solar panel cool down. Then disassemble the equipment carefully and return it.

### 5.3.2 Questions – Students

Use an extra sheet to answer the question.

1. What is an ampere? What is a milliampere?
2. Is the milliampere a useful measure to see at which angle the solar panel works best?
3. What did you find out about the orientation of your solar panel to the light source?
4. Why is it important to keep the center of the solar panel exactly the same distance away from the light source for each different angle? Is this important when using sunlight as a source?
5. How did your prediction for the 10-degree angle compare with your actual result? How did you adjust your predictions for the other angles? Did they become more accurate as a result of your actual measurements?
6. With your graph could you make a fairly accurate prediction of the current for 25 degrees or 75 degrees? Is there any way to check your predictions for 25° and 75°?
7. To obtain the maximum current, we aimed the light source and the solar panel along the same line. The sun appears to move both horizontally and vertically. What would you need to know before you permanently attached a solar panel on top of your school?
8. Will the rate of electrical energy production be the same for every day of the year? Why or why not? How could you plan for this? Would your solution necessarily be a practical one?
9. What is the answer to the question at the beginning of this investigation: How can we maximize the electrical power coming from the solar panel?

### 5.3.3 Template for Solar Panel Orientation

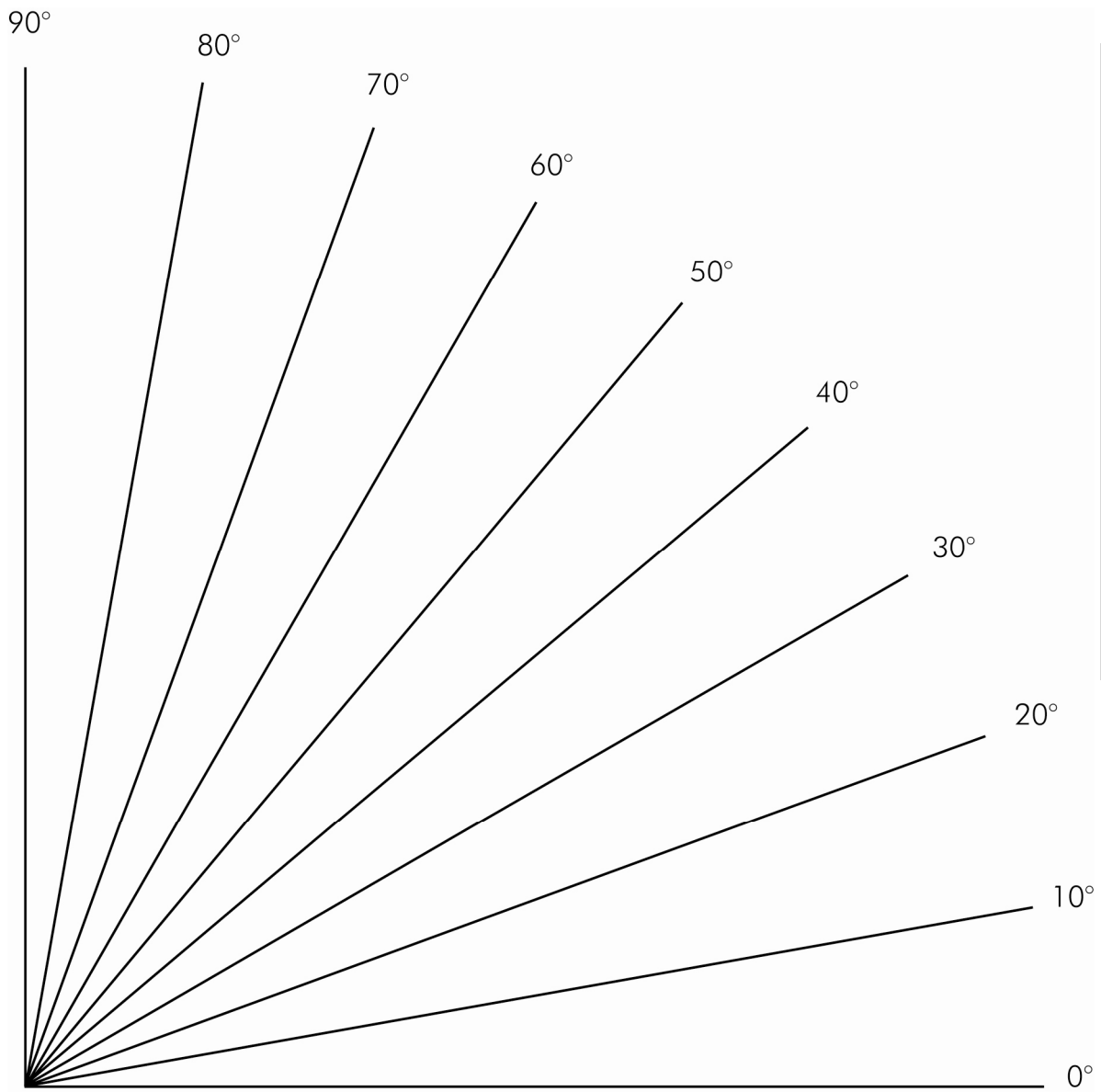

Student's Section

Fig. 5-10 Template for solar panel orientation