

X-ray apparatus U192001

Instruction sheet

05/11 ALF / Hh

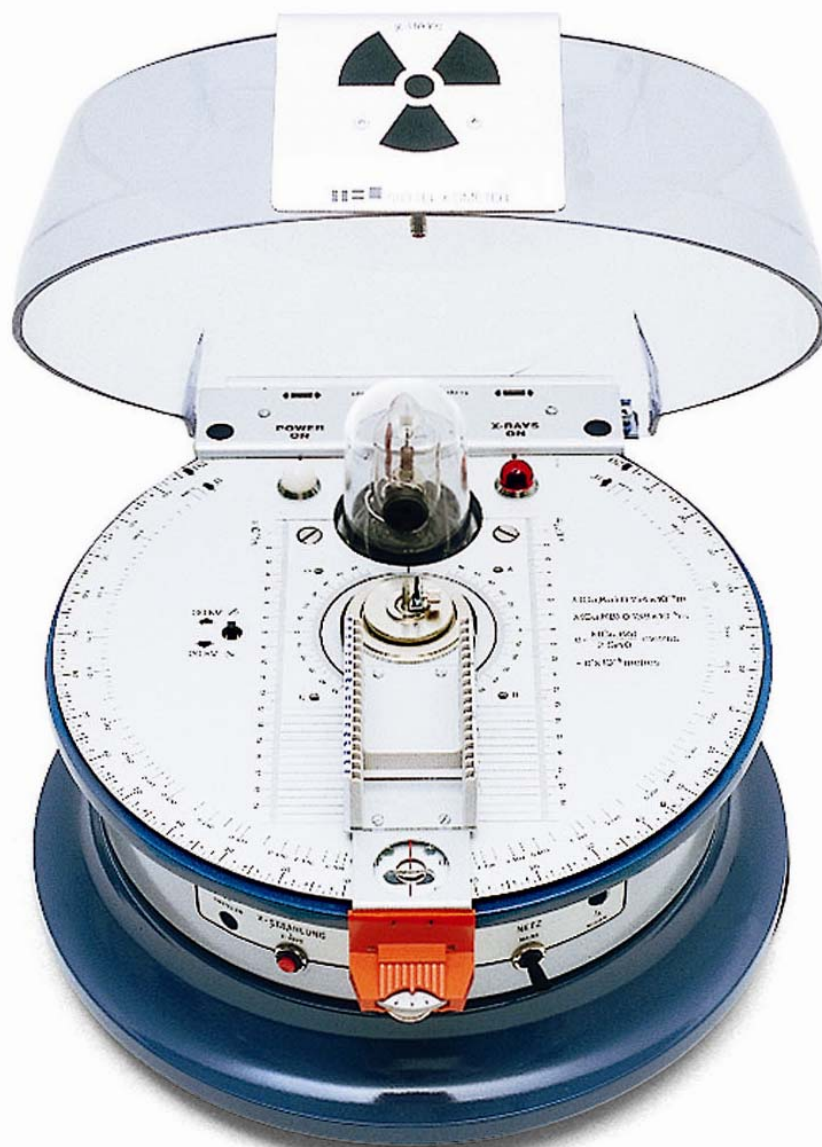

1. Protection from radiation

From the first use of the X-ray apparatus to the last, you must ensure that any planned use is in conformance with local legislation, stipulations and regulations and has been approved by the responsible authorities or otherwise certified.

High voltage may only be applied when the cover is closed and the safety circuitry is correctly connected and activated. Only when this has been done can the X-ray apparatus be operated. The housing is secured against unauthorised opening by means of a self-tapping screw. This prevents X-ray radiation from escaping and allows experiments to be performed in safety.

The maximum operating parameters $U = 30$ kV and $I = 100$ μ A must not be exceeded.

Every time the X-ray apparatus is used, the radiation protection equipment must be checked as specified in Section 8.1.

Never open the housing of the X-ray apparatus. Any attempt to manipulate, repair or otherwise tamper with the equipment other than setting it up for use in a laboratory invalidates the certification for this type of equipment and it may no longer be used for any purpose. Repairs may only be made by the manufacturer UK 3B Scientific Ltd.

- The apparatus must be secured in such a way as to prevent unauthorised access.

2. Safety instructions

The X-ray apparatus conforms to safety regulations for electrical measuring, control and laboratory equipment as specified in DIN EN 61010 Part 1 and is designed to meet protection classification I. It is to be operated in dry rooms as appropriate for the use of electrical equipment.

Safe operation of this equipment is guaranteed as long as it is used as stipulated. However, there is no guarantee of safety if the equipment is used incorrectly or carelessly. If there is any suspicion that the equipment can no longer be operated without risk (e.g. if visible damage is detected), the equipment must immediately be withdrawn from use and secured in such a way as to prevent its inadvertent operation.

- As soon as you have unpacked the X-ray apparatus, check it for any signs of damage that may have occurred during transport. If any damage is found, do not attempt to operate the equipment but inform the manufacturer UK 3B Scientific Ltd.
- Please do not dispose of the packaging, since it might be handy should you need to return the item.
- Before using the equipment for the first time, ensure that the mains voltage selector switch is set to the right voltage.

Due to the high dosage potential inside the X-ray apparatus, users are obliged to treat the equipment with special care.

- Before any use of the X-ray apparatus, the housing, the cover plus the control and display elements should all be checked and in particular the radiation protection equipment must be checked as specified in Section 8.1.
- If any damage is found, the equipment must immediately be withdrawn from use and secured in such a way as to prevent its inadvertent operation.
- If any malfunction occurs, the equipment must immediately be withdrawn from use and secured in such a way as to prevent its inadvertent operation.
- If the high voltage indicator lamp is lit even though the cover has not been fully closed and locked in its central position, the equipment must immediately be withdrawn from use.

If the cathode heater filament of the tube is not operating, then no “afterflash” (spark discharge of the tube heater filament on disconnection of high voltage) can take effect when the high voltage supply is turned off. In this event, a high voltage can remain in effect in the tube for up to 6 hours after disconnection.

- For this reason you should not touch any of the high voltage terminals for at least 6 hours after failure of the cathode.
- When replacing bulbs or fuses, always disconnect from the mains.

3. Components and control elements



- 1 Fine adjustment trimmer for goniometer
- 2 Trimming potentiometer for setting emitter current
- 3 High voltage ON/OFF button
- 4 Housing
- 5 Base

- 6 Timer
- 7 Key switch for mains supply
- 8 Jack socket for emitter current measurement, giving an output voltage proportional to current
- 9 Cover
- 10 Screening plate with radiation warning label



10
22

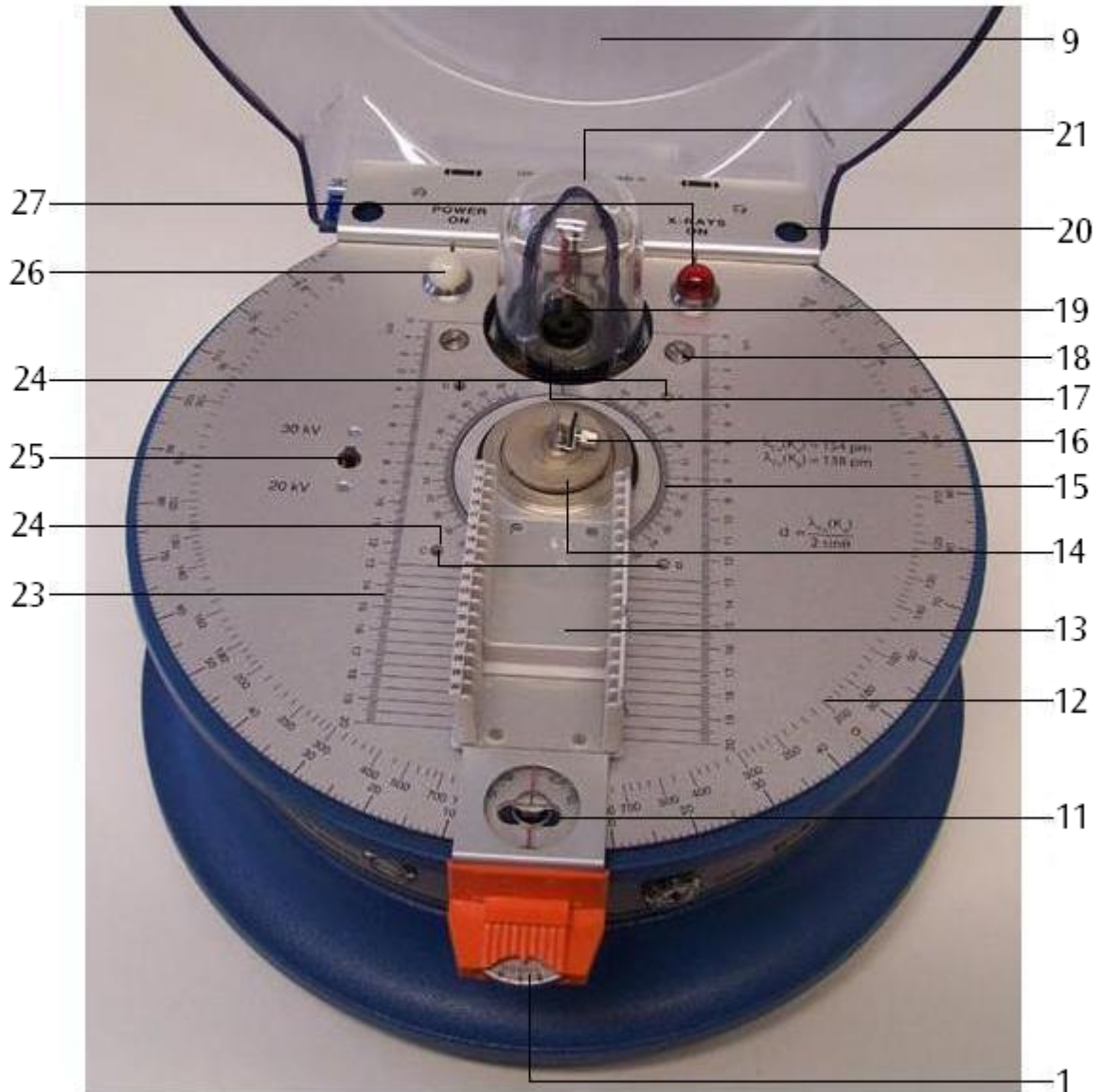

- | | |
|--|--|
| 11 Dumbbell shaped slot for locking the cover | 19 X-ray tube |
| 12 Protractor scale for measuring arm | 20 Access holes |
| 13 Measuring arm with magazine for photographic slides | 21 Leaded glass dome |
| 14 Pressure plate | 22 Locking pin for cover |
| 15 Protractor scale for sample holder | 23 Length scale for focal point |
| 16 Sample holder | 24 4-mm sockets for addition of driver motor |
| 17 Radiation exit window with brass collimator | 25 High voltage selector switch |
| 18 Securing screws for leaded glass dome | 26 Mains voltage indicator lamp (white) |
| | 27 High voltage indicator lamp (red) |



- 28 Circuit breaker for mains supply
- 29 Circuit breaker for high voltage supply
- 30 Mains voltage selector switch

- 31 Ventilation grille
- 32 Mains socket

4. Description

The X-ray apparatus allows you to undertake a wide variety of experiments on the following topics:

- Properties of X-rays:
 - Penetration by X-rays
 - Straight-line propagation
 - Ionisation
 - X-ray photography
- Fluorescence
- Shielding from X-rays
- Absorption experiments
- Distance law
- Dosimetry and radiation protection
- Refraction of X-ray beams:
 - Laue imaging
 - Debye-Scherrer imaging
- Bragg reflections
 - Duane-Hunt displacement law (determination of Planck's constant h)
- Moseley's law

A horizontal counter tube goniometer is built into the X-ray apparatus that consists of a pivoting measurement arm with a sample holder on its axis of

rotation. The arm takes the form of a magazine for photographic slides and can also accommodate a Geiger-Müller counter (U19201), an ionisation chamber (U19208) and various experimental equipment, either in the shape of slides or mounted on a 50 mm x 50 mm baseplate (e.g. U19205, U19206, U19207). The pivoting arm can be turned by hand around the sample holder or can be coupled to a fixed angle at a 2:1 ratio for experiments on Bragg reflection, for example. The space where the experiment takes place is inside a closed housing with a transparent, radiation-proof cover. The cover has a safety lock that prevents it from being opened until the high-voltage ON/OFF button has been switched to OFF and a delay of 2 seconds has elapsed for the decay of the high voltage. A timer for a period of up to one hour allows you to set up long exposures and means that the equipment does not continue operating for long periods without supervision. The highly evacuated X-ray tube with its directly heated tungsten cathode and copper anode is made of borosilicate glass with a concave, thin-walled exit window. A leaded glass cover with a brass collimator allows the X-ray beam to exit parallel to the top of the apparatus and prevents any scattered radiation from escaping. The emitted X-ray beam strikes a lead-aluminium screening plate bearing a radiation symbol of the same diameter as the uncollimated X-ray beam

5. Scope of delivery

- 1 Basic apparatus
- 1 X-ray tube
- 1 Jack plug
- 2 Fuses
- 1 Radiation warning plates in German, English, French and Spanish
- 1 Instruction sheet

6. Technical data

X-ray tube:

Anode voltage:	20/30 kV selectable, electronic stabilisation
Emitter current:	0 to 80 μA continuously adjustable with electronic stabilisation
Radiation dosage:	$< 0.1 \text{ mrem/h}^{-1}$ at 0.1 m from accessible surfaces
Heated cathode:	4 V, 1 A
Focal point:	5 mm x 1 mm
Anode material:	Cu
Leaded glass collimator:	5 mm dia.
Beam divergence:	Better than 10°
Wavelength of charact. radiation:	Cu - K_α : 154 pm Cu - K_β : 138 pm
Dimensions:	100 mm x 32 mm dia.

Counter tube goniometer:

Pivot range:	0° $+10^\circ$ to $+130^\circ$ and -10° to -130° relative to axis of beam
Angle coupling:	Independent of sample holder alignment or in the ratio 2:1
Accuracy of Bragg angle 2θ :	5 minutes of arc
Timer:	0 to 60 min, continuously adjustable
Mains:	115 V/230 V, 50/60 Hz via mains lead
Power consumption:	100 VA
Dimensions:	250 mm x 370 mm dia.
Weight:	9 kg

7. Spares and accessories

1. Spare X-ray tube U19204

2. Basic equipment set U19205

The basic equipment set allows for qualitative and quantitative experiments, e.g. on straight-line propagation, ionisation, penetration by X-rays and X-ray photograph, demonstration of the wave nature of X-ray radiation, investigation of X-ray fluorescence and determination of mass-absorption coefficients.

Scope of delivery:

- 1 Fluorescent screen
- 1 Debye-Scherrer camera
- 2 Film cartridges
- 1 Lead stencil
- 2 Plate electrodes on 4-mm plug
- 1 Slotted collimator aperture, 1 mm
- 1 Pinhole collimator aperture, 1 mm \emptyset
- 1 Spare magazine with circular apertures
- 2 Slotted apertures, 1 mm/3 mm
- 1 Circular aperture, 9.5 mm dia.
- 2 Monocrystals, LiF, NaCl
- 2 Miniature crystals, LiF
- 1 Powder sample, LiF
- 10 Copper wires
- 4 Absorption films, Ni, Cu, Co, Zn
- 1 Revolver for scattering films, coated with the following elements V, Cr, Mn, Fe, Co, Ni, Cu, Zn
- 1 Remote controller for scattering film revolver
- 1 Set of assembly aids (acetate adhesive, clips)
- 1 Storage box, with moulded inlays for equipment

3. Crystallography accessories U19206

These crystallography accessories allow for advanced crystallographic studies, derivation of Moseley's law, the Debye-Scherrer procedure, Bragg reflections and material analysis.

Scope of delivery:

- 4 Films, Fe, V, Mn, Cr
- 2 Monocrystals, KCl, RbCl
- 5 Powder samples. NaF, SiC, NH_4Cl , MgO, Al
- 2 Sets of wire samples, Al, Nb (3 each) for Debye-Scherrer experiments
- 10 Polyethylene fibres
- 1 Disc for calculating Bragg reflection angle

4. Radiography accessories U19207

These radiography accessories allow for experiments on the following topics: scattering, absorption; dependence of penetration on accelerating voltage or emitter current, resolution, screening,

half-value thickness (HVT); exposure times, non-destructive material analysis.

Scope of delivery:

- 1 Maltese cross
- 1 Phantom
- 1 Circular aperture
- 1 Aluminium layer, stepped
- 5 Aluminium absorbers, 0.1/0.25/0.5/1.0/2.0 mm
- 1 Lead absorber, 0.5 mm
- 1 Plastic absorber
- 2 Magnets
- 4 Material testing models (porosity, cracks, weld, painting)

5. Film-pack 2 U19209

Film-pack 2 contains highly sensitive films for radiography using α , β and X-ray radiation. The films are individually wrapped in opaque plastic covers and can be developed and fixed in daylight.

Scope of delivery:

- 20 Films 38 mm x 35 mm in opaque plastic wrappers
- 1 Bottle of X-ray developer
- 1 Bottle of X-ray fixer
- 1 Syringe with cannula for injecting chemicals into the film wrappers.
- 1 Metal clips

6. Film-pack 4 U19210

As per Film-pack 2 except:

- 12 Films 150 mm x 12 mm in opaque plastic wrappers for Debye-Scherrer camera.

7. Motor drive U19202-115 or U19202-230

A motor drive is used in conjunction with a Debye-Scherrer camera for analysing structures using the rotating crystal method.

Mains: 115/230 V, 50/60 Hz

Power consumption: 3 VA

8. Ionisation chamber U19208

The ionisation chamber is for investigating the ionisation of air and other gases by X-rays at differing pressures (saturation characteristic, Geiger-Müller tube model, dosimetry).

Operating voltage: max. 2 kV

Ionisation current: 10^{-11} to 10^{-10} A

Rod electrode: 75 mm long

Chamber: 85 mm x 25 mm dia.

Tubing: 5 mm dia.

9. Geiger-Müller tube U19201

The Geiger-Müller counter tube is a self-quenching halogen-trigger counter tube for registering α , β , γ and X radiation.

Dose rate range: 10^{-3} to 10^2 mGy/h

Mass of active surface (mica):
2.0 to 3.0 mg/cm²

Operating voltage: 500 V

Connection: BNC

Cable length: 1 m

Dimensions: 57 mm x 22 mm dia.

10. Ratemeter U19203

The ratemeter counts pulses from a counter tube and measures emitter current in an X-ray tube. In conjunction with a digital display with an adjustable threshold (U18620), the output signals, counter tube voltage, pulse rates and current can all be displayed directly.

Current measuring input: Jack socket

0 to 200 μ A

Ratemeter meas. range: 0-2,000 pulses/s

0-20,000 pulses/s

Trigger times: 3 s, 15 s, 30 s, 60 s

11. Digital display with adjustable threshold U18620

This digital display with adjustable threshold is intended for immediate use with the ratemeter (U19203). It has four input channels and the upper and lower limits for these can be signalled audibly.

Display: 3½ digits, 12.5 mm high

Dimensions : 105 mm x 76 mm

8. Operation

8.1 Checking radiation protection equipment

Every time the X-ray apparatus is used, you should check in advance that the equipment relating to radiation protection is functioning correctly. This check should be conducted in the sequence that follows. In the event of any of these steps revealing a problem, the equipment must immediately be unplugged from the mains. If the problem cannot be eliminated by following the suggestions listed in Section 10, the X-ray apparatus will need to be repaired by the manufacturer. Only if this safety check is completed successfully may the X-ray equipment be used.

- Check the cover for damage.
- Check that the screening plate with the radiation sign is firmly secured.

- Check the locking pin of the cover for any damage.
- Check that the leaded glass dome and brass collimator are free of damage and firmly secured.
- Check that the mains indicator lamp is functioning correctly by closing the cover, connecting the equipment to the mains, setting the timer and turning on the key switch. The indicator lamp should then light. The high voltage indicator should not be lit.
- Check that the timer is working properly by turning on the key switch and setting a time.
- Check the timer relay by setting the timer to 0. The mains indicator should not be lit even if the equipment is plugged in.
- Check the high voltage indicator lamp. Set a time on the timer with the cover closed and locked (locking pin in centre position) and turn on the key switch. The high-voltage indicator lamp should not light up at this stage. Switch on the high voltage using the ON/OFF button. The indicator lamp and the light-ring of the button should then light up.
- Check the switching function of the safety device in the cover hinge as follows: with the high voltage switched on, slide the cover sideways without opening it, so that the locking knob remains within one end of the dumbbell-shaped slot. The high voltage should switch off automatically, so that the high-voltage indicator lamp and the light-ring also go off.

8.2 Putting the X-ray apparatus into operation

8.2.1 Opening, closing and locking the cover

- To open the cover towards the side where the measuring arm is located, push it sideways and lift it open.
- To close the cover, insert the locking pin into the dumbbell slot on the side where the measuring arm is located.
- Push the cover sideways so that the locking pin audibly snaps into the centre position.

The cover is now secured against any unintentional opening. The high voltage supply may now be switched on.

8.2.2 Turning on the X-ray apparatus

- Select a time on the timer.
- Turn on the X-ray apparatus using the key switch.

The mains indicator lamp should now light up. Once the time is up, the machine should switch itself off.

8.2.3 Closing the cover and switching on the high voltage

- Once the mains is connected, select the high voltage supply $U = 20 \text{ kV}/30 \text{ kV}$ via the slide switch.
- Close the cover and lock it with the locking pin in the centre position.
- Press the high voltage button.

The high-voltage indicator lamp and the light-ring of the ON/OFF button light up, and X-radiation is generated.

- Check for the presence of an X-ray beam using the fluorescent screen, ionisation chamber or Geiger-Müller tube.

8.2.4 Setting and measuring emitter current

- Connect a voltmeter with a measurement range of 10 V DC to the jack socket using an adapter cable.
- Use a screwdriver to set the desired emitter current on the trim potentiometer.

The following relationship applies:

$$I_A [\text{A}] = U_A [\text{V}] / 10^5 [\text{Ohm}]$$

Thus, for example, a DC voltage of 8 V indicated on the voltmeter corresponds to a tube current of 80 μA .¹

8.2.5 Switching off the high voltage and opening the cover

- Press the high-voltage ON/OFF button, allow the delay time needed for the unlocking of the cover safety catch, and slide the cover sideways.

8.2.6 Sample holder

Monocrystals (NaCl, LiF, etc.) can be attached to the sample holder (see Fig. 5). The clamp and base can be removed by undoing the relevant screw.

- Fix the monocrystal into the sample holder with the clamp thus defining the angular alignment of the crystal. The rough side of the crystal should point towards the X-ray tube.
- Read off the angle θ between the sample holder and the beam axis.

8.2.7 Measuring arm

The measuring arm has 18 slots for experiment accessories and detectors. An angle between measuring arm and X-ray beam of 2θ can be read on the arm's protractor scale. For accurate measurement of angle there is also a vernier scale. It is used as follows:

- Set the arm to the next whole marking for 2θ .
- Set the fine adjustment trimmer against the thread tension to 0 while holding the measuring arm.

The arm can be set by an extra $\pm 4^\circ$ using the fine adjustment trimmer.

- Read of the relative angle from the vernier (accurate to about 5 minutes of arc).

8.2.8 Angle coupling 2:1

To photograph a Bragg spectrum the measuring arm needs to be set to twice the crystal angle 2θ while the sample holder is rotated by a given angle θ .

- Set both the measuring arm and the sample holder to precisely $\theta = 0^\circ$.
- Carefully screw in the pressure plate.

Now when the measuring arm is moved, the sample holder rotates by precisely half the angle (see Fig. 4).

- To decouple the two elements, unscrew the pressure plate by one or two turns.

8.3 Changing fuses

- Disconnect the mains plug.

8.3.1 Mains fuse

- Unscrew the fuse holder for the mains fuse from the bottom of the housing.
- Insert a new fuse of the correct value (T1A, 250 V).
- Screw the fuse holder back in.

8.3.2 High voltage fuse

- Unscrew the fuse holder for the high voltage fuse from the bottom of the housing.
- Insert a new fuse of the correct value (T1A, 250 V).
- Screw the fuse holder back in.

8.4 Changing bulbs

- Disconnect the mains plug.
- Remove the plastic cover for the mains or high voltage indicator as appropriate
- Unscrew the lamp with the help of a short section of plastic tubing and replace the bulb:
Mains voltage indicator lamp: 6 V / 0.05 A
High voltage indicator lamp: 6 V / 0.1 A
- Screw the cover back on.

8.5 Adjustment of X-ray tube

The X-ray apparatus is supplied having been pre-adjusted at the factory. There will usually be no need to adjust it any more. However, it is possible for the adjustment to have been lost during transport so that re-adjustment becomes necessary.

8.5.1 Height adjustment of X-ray tube

- Insert the counter tube into slots 17 and 20 of the measuring arm and rotate it to 0° .
- Take a 1-mm horizontal slot aperture (from U19205) and insert it into slot 13.
- Position an aperture of 1 mm dia. (from U19205) on the brass collimator of the leaded glass dome.

- Turn on the X-ray apparatus and select a high voltage of 20 kV.

- Set the emitter current so that the counter tube registers around 200 to 400 pulses per second (see 8.2.4).

- Remove the rubber stopper from the bottom of the apparatus at the rear to access the screw for adjusting the height of the tube and set it up so that the maximum rate of count is obtained.

- Replace the rubber stopper.

8.5.2 Sideways adjustment of X-ray tube

- Turn off the X-ray tube and open the cover.
- Insert a 1-mm slotted aperture (from U19205) into slot 30 so that it is aligned vertically.
- Fix a 1-mm slotted aperture (from U19205) to the brass collimator of the leaded glass dome so that it is aligned vertically.

- Remove the clamp from the sample holder and place the mounting clip for glass rods (from U19205) in the sample holder (see Fig. 5).

- Turn on the mains.

- Aim the tube through the crossover between the two slot apertures. The glass rod should be precisely in the middle of the cathode reflex on the anode.

- If it is not in this position, release the securing screws and rotate the leaded glass dome by a small angle.

- Remove the glass rod and clip.

- For this fine adjustment, place a lithium fluoride (LiF) miniature crystal in the sample holder.

- Turn the measuring arm and sample holder to 0° .

- Set up the 2:1 angle coupling (see 8.2.8).

- Move the measuring arm to an angle $2\theta = 45^\circ$. You should select the side of the goniometer so that impinging and reflected beams are on the angled side of the sample holder (see Fig. 5).

- Set the high voltage to 30 kV, close the cover and turn on the high voltage.

- Look for the Cu-K_α reflex maximum (quoted value for LiF = $44^\circ 56'$). The measured value should be within $30'$ of the quoted value.

- If the measured value is outside this tolerance, check through the previous steps and repeat them if necessary.

- If the measured value is still outside the tolerance, set the measuring arm to the average of the measured and quoted values.

- Remove the rubber stopper at the top on the rear of the housing to access the screw for changing the inclination of the tube and adjust it until the counter rate reaches a maximum.

- Move the measuring arm to find a maximum for the reflex. If necessary, keep adjusting until the measured and quoted values do lie within the 30' tolerance.

9. Operating instructions for accessories

9.1 Inserting the collimators (from U19205)

The collimators serve to reduce the divergence of the beam.

- Simply plug one of the collimators directly onto the brass collimator of the leaded glass dome.

9.2 Inserting apertures and other experimental items in photographic slide format onto the measuring arm.

- Simply slot the slide into the required slot and clamp it using the spring clip.

9.3 Ionisation chamber (U19208)

- Assemble the ionisation chamber as in Fig. 6.

To demonstrate the ionising effect of X-rays at normal pressures, use the chamber cover with the wide opening. For low pressure (principle of the Geiger-Müller tube), use the lid with the vacuum pump connection.

- Thread the voltage leads and, if necessary, the pump hose through the openings from the experiment chamber. Experiment leads should be equipped with the supplied plugs.
- Slot the ionisation chamber onto the measuring arm (see Fig. 2).

9.4 Geiger-Müller tube (U19201)

- Slot the tube holder onto the slide holder of the measuring arm and secure it with the spring clips. (see Fig. 3)

9.5 Revolver for scattering films (from U19205)

The scattering film revolver is a revolving holder for 8 different metal films that can be rotated into the beam one after the other using a remote trigger. The symbols for the elements are shown in a window on the reverse of the revolver.

- Remove the clamp for the sample holder (see Fig. 9).
- Position the revolver on the sample holder with the hemispherical recess facing downwards.
- Screw the remote triggering device onto the scattering film revolver and check that it is working properly.
- Thread the remote trigger through to the outside under the cover.

9.6 Debye-Scherrer camera (from U19205) with motor drive (U19202)

The Debye-Scherrer camera is made up of three parts: housing, cover and a clamp with bevel gear (see Fig. 7). The motor drive can be used, for example, to take rotating crystal images.

- Remove the clamp from the sample holder and set the measuring arm to an angle $2\theta = 90^\circ$ and the sample holder to $\theta = 90^\circ$. Make sure that the smooth side of the sample holder is pointing towards the tube.
- Fix a 1-mm collimator to the brass collimator on the leaded glass dome.
- Try out the positioning of the Debye-Scherrer camera housing between the leaded glass dome and the sample holder (see Fig. 7). If there is no room for play in the camera, it can be adjusted using the screw in the bottom of the camera.
- Load the camera with a film from Filmpack 4 (U19210) inside a dark room. Make sure the film is firmly placed inside the inner cylinder.
- For rotating crystal images, a film from Filmpack 2 (U19209) should also be placed on the bottom of the camera.
- Position the sample in the padding around the hole of the clamp, close the lid of the camera and slot the clamp with the clamped sample into the camera itself.
- Place the camera on the sample holder.
- If required, also set up the motor drive (U19202) as in Fig. 8. Plug its connectors into the 4-mm socket. Make sure the bevel gear is able to turn freely. Using the supplied Allen key, the inclination of the motor's bevel gear can be adjusted.

9.7 X-ray films (U19209/U19210)

9.7.1 Development

- Before sucking developer fluid into the syringe, raise the plunger by 1 ml so that there will be some air above the fluid. This ensures that all the fluid from the syringe and the cannula enters the film wrapper when injected.
- Insert the cannula into one of the openings next to the printing on the film wrapper and inject the developer into the wrapper.

Make sure that both sides of the film are coated with developer and that the developer is well distributed within the wrapper throughout the development process.

- You can achieve this by applying slight pressure to the wrapper with your thumb and forefinger.
- Once the development time has elapsed, you can inject fixer into the wrapper without removing the developer first.

Development	Developer	Fixer
Time	1½ min.	4 min.
Filmpack 2	2½ ml	3½ ml
Filmpack 4	3½ ml	5 ml

9.7.2 Removing the film

- After the film has been developed, snip off one corner of the wrapper with scissors and apply slight pressure to force all the liquid out of the wrapper.
- Then snip off one edge of the wrapper and use a metal clip to pull the film out.
- Wash the film for a few minutes in running water before viewing.

If the film is to be archived, it will require another 10 minutes of fixing and 30 minutes more washing in running water. Normal fixer with or without hardeners can be used for this.

9.7.3 Storage of chemicals

Whereas fixer is relatively stable, the developer can decompose as a result of air in the bottle.

- If developer needs to be kept for a long time though the bottle is already partially empty, it is

better if it is transferred to a smaller container. This means it remains usable for longer.

- Before closing the developer bottle, squeeze the bottle so that the fluid comes to brim before closing it. This ensures that as little air as possible remains above the fluid in the bottle.
- Observe local regulations when disposing of chemicals.

9.7.4 General information

When exposing X-ray film, the distance of the film from the object should be kept as small as possible and the distance of the film from the radiation source as large as possible for the required exposure time and size of radiation source.

The film can also undergo exposure from beta and gamma radiation emitted from low energy sources that may be present in a school.

If the film is irradiated with a relatively large quantity of "soft" X-ray radiation, the pattern of the wrapper may appear on the developed image.

When the film is sealed into its PVC wrapper, pressure points sometimes appear at the edges. After development these pressure points may appear as dark black patches.

10 Troubleshooting

Fault	Possible causes	Solutions
Mains indicator light is not working even though the mains connection has been checked.	<ul style="list-style-type: none"> Timer is set to 0 Mains fuse has blown High voltage fuse has blown Indicator bulb has blown Other causes 	<ul style="list-style-type: none"> Set a short timer period. Replace the fuse (see Section 8.3). Replace the fuse (see Section 8.3). Replace the bulb (see Section 8.4). The equipment needs to be checked by the manufacturer.
Cathode heater fails to glow, although the high voltage is switched on, the preselected tube current is greater than zero, and the mains voltage indicator lamp shows "ON"	<ul style="list-style-type: none"> Cathode is faulty Heater control circuit is faulty 	<ul style="list-style-type: none"> The equipment needs to be checked by the manufacturer.

<p>High voltage indicator light is not working even though the mains indicator is on</p>	<p>Safety circuit</p> <p>Indicator bulb has blown</p> <p>Other causes</p>	<p>Check the safety circuit as specified in Section 8.1, especially the fastening of the leaded glass dome and the hinges and locking of the cover.</p> <p>Replace the bulb (see Section 8.4).</p> <p>The equipment needs to be checked by the manufacturer.</p>
<p>High voltage "crackles" shortly after switching on</p>	<p>Moisture under the leaded glass dome</p>	<p>Unlock and remove the lead glass dome, wipe it with a dry cloth, and replace it and lock it.</p>
<p>The cathode lights up brightly for a short time after the high voltage has been switched off („After-flash“)</p>	<p>This is not a fault, its purpose is to allow discharging of the high-voltage components.</p>	
<p>No X-ray beam although the high voltage is turned on</p>	<p>The cathode is not lit</p> <p>The emitter current is too small</p> <p>No emitter current</p> <p>Collimators or such like in the way of the beam</p> <p>X-ray tube has lost its adjustment</p>	<p>The equipment needs to be checked by the manufacturer. Caution: high voltage remains in effect for several hours after the tube has been switched off!</p> <p>Adjust the emitter current (see Section 8.2.4)</p> <p>The equipment needs to be checked by the manufacturer.</p> <p>Check the set-up for the experiment</p> <p>Adjust the X-ray tube (see Section 8.5)</p>

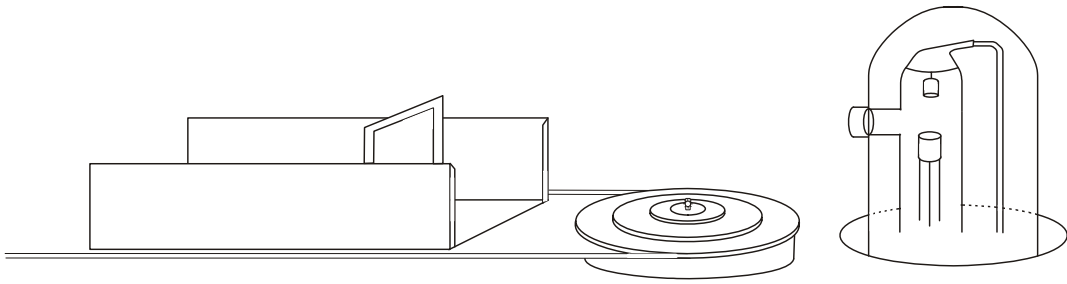

Fig. 1 Inserting the fluorescent screen onto the measuring arm

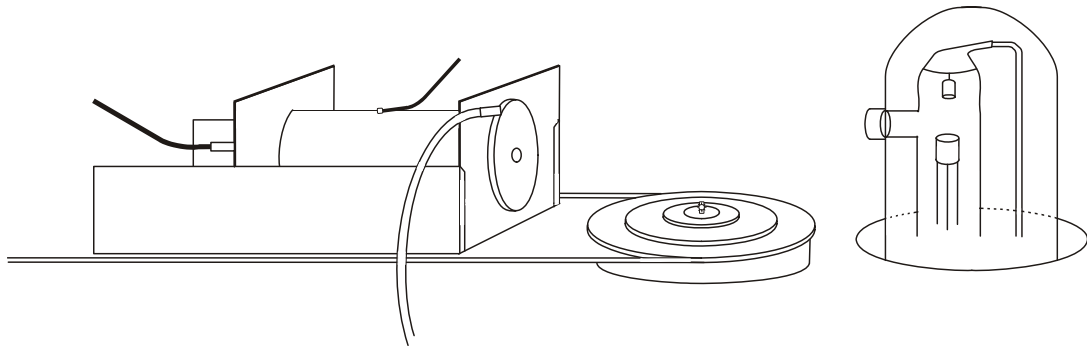

Fig. 2 Inserting the ionisation chamber onto the measuring arm

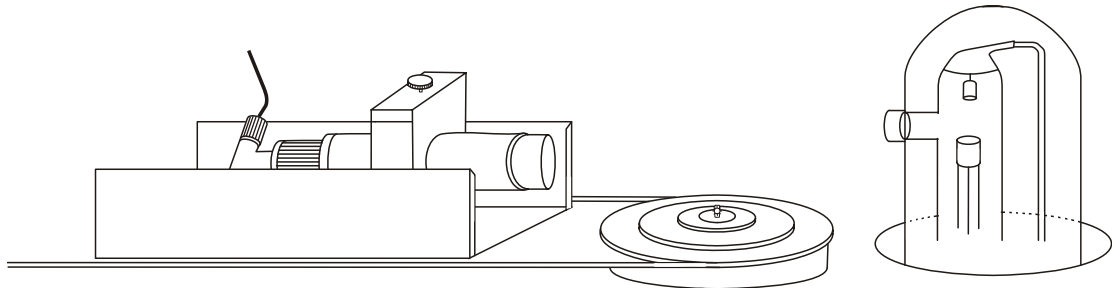

Fig. 3 Inserting the Geiger-Müller tube onto the measuring arm

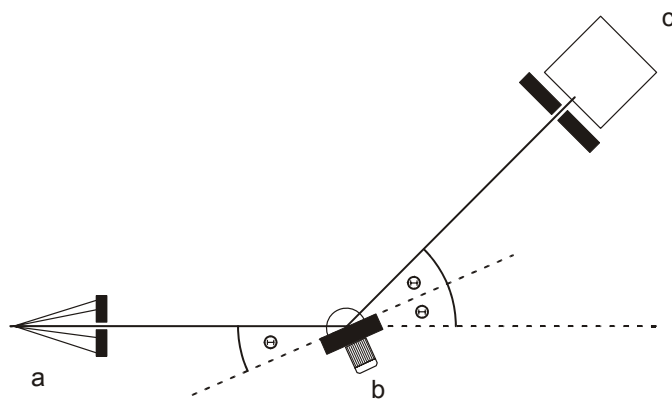

Fig. 4 Geometry of Bragg reflections (a. X-ray tube, b. Monocrystal, c. Counter tube)

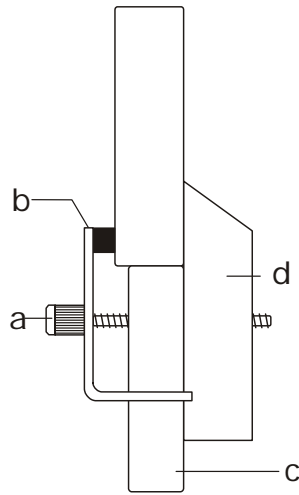

Fig. 5 Insertion of crystal into sample holder (a Screw, b Clamp, c Base, d Fixed section of sample holder)

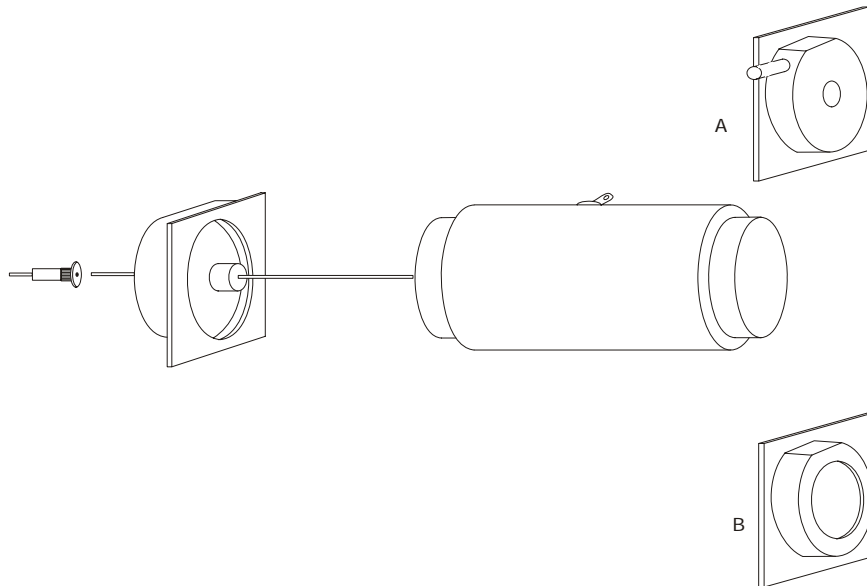

Fig. 6 Assembly of ionisation chamber (A for low pressure, B for normal atmospheric pressure)

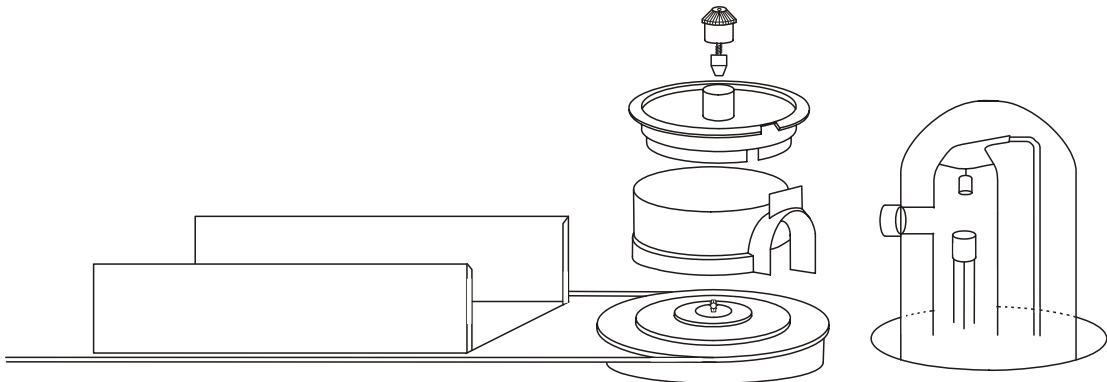

Fig. 7 Insertion and removal of Debye-Scherrer camera

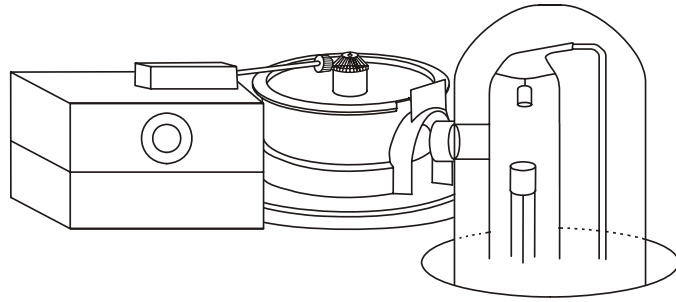

Fig. 8 Debye-Scherrer camera with motor drive

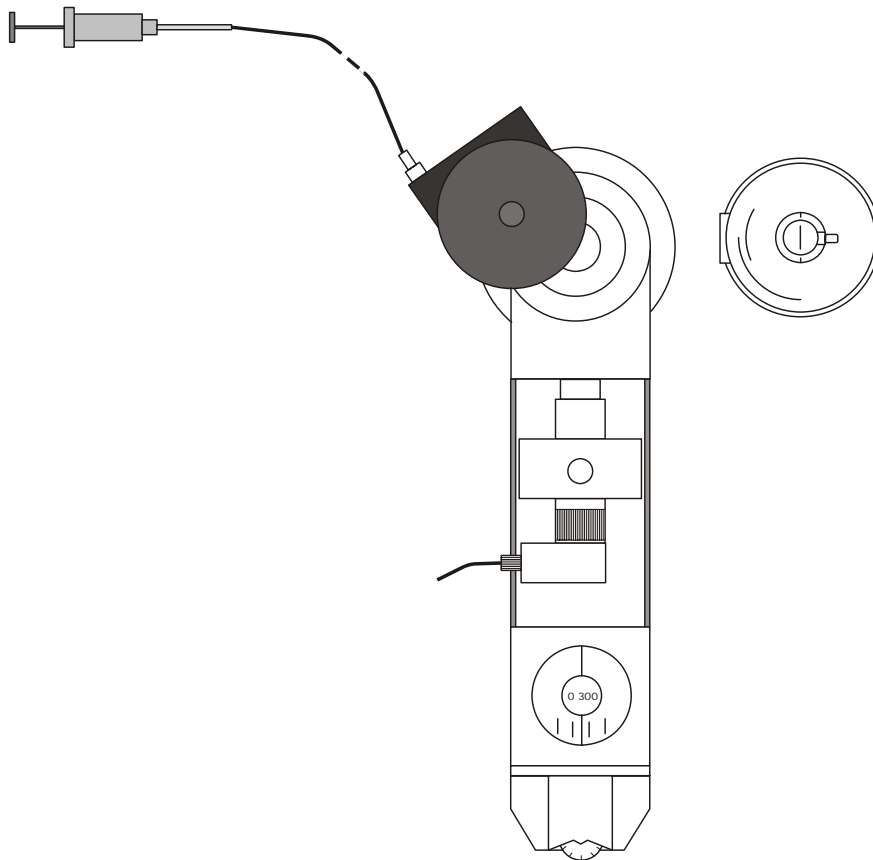

Fig. 9 Insertion of scattering film revolver magazine

